

PermaShield[®]

Stainless Steel Corrosive
Fume Exhaust System With
PermaShield Fluoropolymer
Barrier Coating

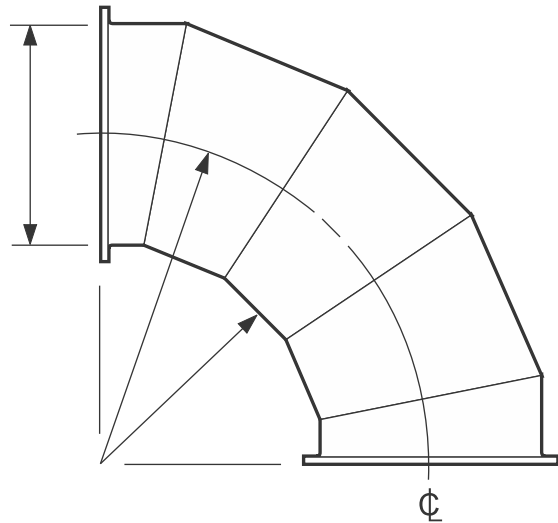

PRODUCT CATALOG

Catalog 04/20.7

Fab-Tech

An Exyte Group Company

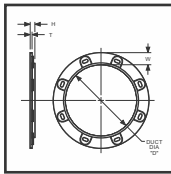

STANDARDS

PermaShield Ductwork Fabrication Standards _____ 4
 Straight Duct Gauge _____ 5
 Ring Mechanical Specifications _____ 6
 Ring Mechanical Specifications _____ 7
 Gasket Specifications _____ 8
 Gasket Placement For Dissimilar Duct Joint Connections _____ 9
 PSP-EZ™ Clamp Mechanical Specifications _____ 10
 Metric Conversion Chart _____ 11
 Weight Chart EZ Duct / Miscellaneous Fittings _____ 12
 Weight Chart Straight Duct & Elbows: -6 Pressure Class (-1,495 Pa) _____ 13
 Weight Chart Straight Duct & Elbows: -10 Pressure Class (-2,491 Pa) _____ 14
 Weight Chart Straight Duct & Elbows: -14 Pressure Class (-3,487 Pa) _____ 15
 Weight Chart Straight Duct & Elbows: -18 Pressure Class (-4,484 Pa) _____ 16

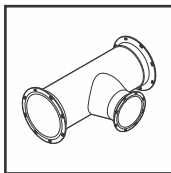

DUCT & FITTINGS

_____ *PRODUCT GUIDE* _____ 17
 Straight Duct _____ 18
 Straight Duct with Fab-Tech Flange (Use with 2" (50.8) & 3" (76.2) EZ Fittings) _____ 19
 Straight Duct with Straight Tap _____ 20
 Straight Duct with Conical Tap _____ 21
 Straight Duct with Shoe Tap _____ 22
 Straight Duct with Lateral Tap _____ 23
 Straight Duct with Multiple Taps _____ 24
 Gored Elbow _____ 25
 Reducer _____ 26
 Offset _____ 27
 End Cap _____ 28
 Mesh End Cap _____ 29
 Concentric Round to Rectangular Transition _____ 30
 Custom Fitting _____ 31

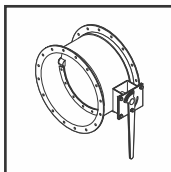

CONTROL DEVICES

_____ *PRODUCT GUIDE* _____ 32
 Round Damper Comparison Chart _____ 33
 Round Damper Comparison Chart _____ 34
 Round Damper Comparison Chart _____ 35
 4" (101.6) - 12" (304.8) Wafer Isolation Damper _____ 36
 2" (50.8) & 3" (76.2) Micro-Adjustable EZ Damper _____ 37
 4" (101.6) - 14" (355.6) Industrial Isolation Damper _____ 38
 6" (152.4) - 14" (355.6) AMCA Industrial Isolation Damper _____ 39
 4" (101.6) - 14" (355.6) Industrial Isolation Short Damper _____ 40
 16" (466.4) - 34" (863.6) AMCA High Value Heavy Duty Industrial Damper _____ 41
 16" (466.4) - 48" (1219.2) High Value Heavy Duty Industrial Damper (HVD) _____ 42
 36" (914.4) - 48" (1219.2) AMCA High Value Heavy Duty Industrial Damper _____ 43
 50" (1270.0) & Larger Reinforced Heavy Duty Industrial Damper _____ 44
 24" (609.6) - 84" (2133.6) Ultra Series Industrial Damper _____ 45
 86" (2184.4) - 120" (3048.0) Ultra Series Dual Blade Industrial Damper _____ 46
 2" (50.8) & 3" (76.2) EZ Blastgate _____ 47
 4" (101.6) - 36" (914.4) Horizontal Run Isolation Blastgate _____ 48
 16" (914.4) - 36" (914.4) Horizontal Run Actuated Isolation Blastgate _____ 49
 38" (965.2) & Larger Horizontal Run Isolation Blastgate _____ 50
 38" (965.2) & Larger Horizontal Run Actuated Isolation Blastgate _____ 51
 4" (101.6) - 36" (914.4) Vertical Run Isolation Blastgate _____ 52
 16" (406.4) - 36" (914.4) Vertical Run Actuated Isolation Blastgate _____ 53
 38" (965.2) & Larger Vertical Run Isolation Blastgate _____ 54
 38" (965.2) & Larger Vertical Run Actuated Isolation Blastgate _____ 55

METRIC EQUIVALENTS ARE SHOWN IN PARENTHESIS & ITALICS (MILLIMETERS OR AS NOTED)

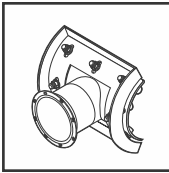

ACCESSORIES _____ *PRODUCT GUIDE* ___ 56

Field Installed Nipple _____ 57

Field Installed Nipple / Test Port _____ 58

Field Installed Saddle Tap _____ 59

Field Installed Hot Tap _____ 60

Cast Ring _____ 61

Angle Ring _____ 62

EZ Clamp Kit _____ 63

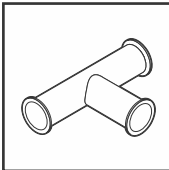

EZ FITTINGS _____ *PRODUCT GUIDE* ___ 64

EZ Straight Duct, Tee and Reducing Tee _____ 65

EZ Double Tee, Lateral, 90° Elbow _____ 66

EZ 45° Elbow, 30° Elbow, Eccentric Reducer _____ 67

EZ Concentric Reducer, Angle Ring to EZ Reducer, End Cap _____ 68

Micro-Adjustable EZ Damper _____ 69

Field Installed Straight Duct EZ Flange _____ 70

EZ Blastgate _____ 71

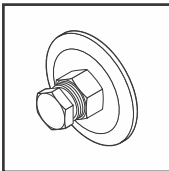

FAB-TECH FLANGE SYSTEM _____ *PRODUCT GUIDE* ___ 72

Fab-Tech Flange _____ 73

KF Flange Adapter _____ 74

NPT Male Nipple Adapter _____ 75

NPT Female Coupler Adapter _____ 76

SWAGELOK® Adapter _____ 77

Dwyer Pitot Adapter _____ 78

Sprinkler Adapter _____ 79

Field Installed 2" (50.8) Fab-Tech Flange _____ 80

Field Installed Fab-Tech Flange Saddle Tap _____ 81

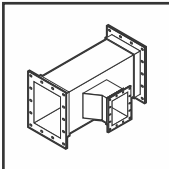

RECTANGULAR DUCT _____ *PRODUCT GUIDE* ___ 82

Mounting Flange Standards _____ 83

Straight Duct _____ 83

Straight Duct with Straight Rectangular Tap _____ 84

Straight Duct with Rectangular Boot Tap _____ 84

Straight Duct with Rectangular Conical Tap _____ 85

Straight Duct with Rectangular Lateral Tap _____ 86

Straight Duct with Round Tap _____ 86

Straight Duct with Multiple Taps _____ 87

90°, 60°, 45°, 30° or Custom Elbow _____ 87

90°, 60°, 45°, 30° or Custom Mitered Elbow _____ 88

Concentric Transition _____ 88

Concentric Rectangular to Round Transition _____ 89

Vertical Offset _____ 89

Horizontal Offset _____ 90

Double Offset _____ 90

End Cap _____ 91

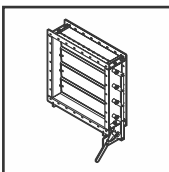

RECTANGULAR CONTROL DEVICES _____ *PRODUCT GUIDE* ___ 92

Rectangular Damper Comparison Chart _____ 93

Industrial Parallel Blade Control Damper _____ 94

Industrial Opposed Blade Control Damper _____ 94

Industrial Backdraft Damper _____ 95

Heavy Duty Parallel Blade Control Damper _____ 96

Heavy Duty Opposed Blade Control Damper _____ 96

Horizontal Blastgate _____ 97

Vertical Blastgate _____ 97

METRIC EQUIVALENTS ARE SHOWN IN PARENTHESIS & ITALICS (MILLIMETERS OR AS NOTED)

PermaShield Ductwork Fabrication Standards

The Fab-Tech Ductwork Fabrication Standard Manual is designed to aid you, our customer, in becoming acquainted with our fabrication practices. The manual is in strict accordance with the practices in the latest S.M.A.C.N.A. manuals.

GENERAL

Codes and Standards

a. **Ducts** shall be listed for use without the necessity for internal fire protection sprinklers or any devices relied on to cut off air flow in the event of fire by the following:

Factory Mutual Research Standard 4922**Limitations and Requirements:**

1. The coating shall be PermaShield® fluoropolymer barrier thermoplastic resin. The average coating thickness per project shall not exceed 12 mils (.012" *0.30mm*).

For straight duct and fittings, the average coating thickness shall fall between:

10 mils +/- 4 mils (.010" +/- .004" *0.254mm +/- 0.102mm*).

For control devices, the average thickness shall fall between:

11 mils +/- 5 mils (.011" +/- .005" *0.279mm +/- 0.127mm*).

Complete and uniform coating coverage is required.

2. This duct may be used for smoke removal in special purpose areas when properly designed and sized. Sprinklers are not required.

3. The product shall be manufactured with identical resins as tested, and according to the formulation on file with FMRC, and shall meet all physical requirements of S.M.A.C.N.A. manual for Industrial Duct Construction Standards.

4. Vertical height of individual risers within the duct system are not restricted, however, they shall not penetrate other fire areas.

5. The manufacturer shall determine the suitability of the duct systems for specific corrosive environments.

6. If the process served by such duct system produces flammable residue or a combustible fume source exceeding 1ft² (*0.09 m²*) in area per inlet which can build up inside the duct, then internal sprinklers will be required.

7. ASTM E-84 Standard Test Method for Surface Burning Characteristics. Tested in flat sheet form at a 20 ga. (*0.95mm*) thickness: Flame Spread 0, Smoke Density 20.

b. **Fab-Tech's FM Global Approval** (4922) extends the widest possible limits from 4" (*101.6mm*) diameter up to and including 60" diameter (*1524.0mm*) duct and fittings.

DUCTWORK

a. **Base Metal** shall be a series 300 Stainless Steel. Longitudinal seams shall be fusion welded. Traverse seams shall be continuous weld. All seams shall be smooth on the interior of duct.

b. **Coating** shall be PermaShield Fluoropolymer Barrier Coating and shall be applied per Factory Mutual Research Corporation's limitations and requirements.

c. **Black Iron Rings** shall be coated with PermaProtect, Black Iron Ring Powder⁴⁴. This heat and chip resistant coating is electro statically applied and sintered to the substrate.

d. **Testing** shall be performed at the factory over the entire coated surface inside and out (where applicable) and edges. The testing shall be performed with a DC spark tester used at 2500 volts.

e. **Delivery, Storage, and Handling:**

1. **Protection:** Protection is factory applied to ends of ductwork to prevent end damage and prevent dirt and moisture from entering ducts and fittings.

2. **Delivery:** Consignee must inspect shipment upon delivery and note any and all damages and discrepancies on Bill of Lading and notify manufacturer within 24 hours.

3. **Storage:** Coated ductwork should not be stored in an area where it will have a chance to be damaged from traffic or debris. All coated ductwork should be stored on cardboard, Styrofoam or similar materials. Where possible, store inside and protect from dirt and debris. Where necessary to store outside, store above ground and enclose with water proof wrapping to protect from dirt and debris.

4. **Handling:** If coating is scratched use appropriate protocol to "spark test" (refer to Installation and Assembly Guide, Field Modification section) and if spark is detected, contact manufacturer for repair instruction.

5. **Welding:** Under no circumstances shall welding or a heat source greater than 300°F (*150°C*) be allowed on the stainless steel surface of the duct.

f. **Duct Assembly** shall be accomplished utilizing either companion rings or Fab-Tech's PSP-EZ™ clamp:

1. Companion rings are available as angle rings in sizes 4" (*101.6*) thru 120" (*3048*) diameter or as cast rings in sizes 4" (*101.6*) thru 14" (*355.6*) diameter. The minimum number of holes for flange connections is one hole for each 4" (*101.6*) of duct circumference to the next higher number.

2. PSP-EZ™ clamps are available in sizes 2" (*50.8*) thru 14" (*355.6*). The PSP-EZ™ band ring style of joining system shall provide a minimum compression load to the gasket of 900 PSI (*6205.28kPa*).

g. **Gasket Technology:**

1. Ring gasket material shall be PermaShield form in place, fully expanded 100% PTFE joint sealant.

4" (*101.6*) - 30" (*762.0*) diameter duct
 .010" (*0.25*) x .75" (*19.05*) tape gasket
 32" (*812.8*) diameter & up duct
 1/4" (*6.35*) x 3/16" (*4.76*) rope gasket

2. PSP-EZ™ clamp gasket material shall be PermaShield form in place, fully expanded 100% PTFE tape or die cut gasket (2" (*50.8*) -3" (*76.2*) diameter).

Fab-Tech
 An Exyte Group Company

Visit our website at www.fabtechinc.com
 Email address: sales@fabtechinc.com

Fab-Tech reserves the right
 to change or modify specifications without notice.
 PSP® and PSP-EZ™ are registered trademarks of Fab-Tech, Inc.

METRIC EQUIVALENTS ARE SHOWN IN PARENTHESIS & ITALICS (MILLIMETERS OR AS NOTED)

Straight Duct Gauge

MIN GAUGE FOR 4' (1219.2) DUCT

MIN GAUGE FOR 8' (2438.4) DUCT

DUCT DIA "D"	-6" WG (-1,495 Pa)	-10" WG (-2,491 Pa)	-14" WG (-3,487 Pa)	-18" WG (-4,484 Pa)	STD DUCT LENGTH
4 (101.6)					
6 (152.4)					
8 (203.2)					
10 (254.0)					
12 (304.8)					
14 (355.6)			20	20	
16 (406.4)			20	20	
18 (457.2)		20	20	20	
20 (508.0)		20	20	20	
22 (558.8)		20	20	20	
24 (609.6)		20	20	20	
26 (660.4)	20	20	20	20	47.25 (1200.15)
28 (711.2)	20	20	20	20	47.25 (1200.15)
30 (762.0)	20	20	20	20	47.25 (1200.15)
32 (812.8)	20	20	20	20	47.25 (1200.15)
34 (863.6)	20	20	20	20	47.25 (1200.15)
36 (914.4)	20	20	20	20	47.25 (1200.15)
38 (965.2)	20	20	20	20	47.25 (1200.15)
40 (1016.0)	20	20	20	20	47.25 (1200.15)
42 (1066.8)	20	20	20	20	47.25 (1200.15)
44 (1117.6)	20	20	20	20	47.25 (1200.15)
46 (1168.4)	20	20	20	20	47.25 (1200.15)
48 (1219.2)	20	20	20	20	47.25 (1200.15)
50 (1270.0)	20	20	20	20	47.25 (1200.15)
52 (1320.8)	20	20	20	20	47.25 (1200.15)
54 (1371.6)	20	20	20	20	47.25 (1200.15)
56 (1422.4)	20	20	20	20	47.25 (1200.15)
58 (1473.2)	20	20	20	20	47.25 (1200.15)
60 (1524.0)	20	20	20	20	47.25 (1200.15)
62 (1574.8)	20	20	20	20	47.25 (1200.15)
64 (1625.6)	20	20	20	20	47.25 (1200.15)
66 (1676.4)	20	20	20	20	47.25 (1200.15)
68 (1727.2)	20	20	20	20	47.25 (1200.15)
70 (1778.0)	20	20	20	20	47.25 (1200.15)
72 (1828.8)	20	20	20	20	47.25 (1200.15)
74 (1879.6)	20	20	20	20	47.25 (1200.15)
76 (1930.4)	20	20	20	20	47.25 (1200.15)
78 (1981.2)	20	20	20	20	47.25 (1200.15)
80 (2032.0)	20	20	20	20	47.25 (1200.15)
82 (2082.8)	20	20	20	20	47.25 (1200.15)
84 (2133.6)	20	20	20	20	47.25 (1200.15)
86 (2184.4)	20	20	20	20	47.25 (1200.15)
88 (2235.2)	20	20	20	20	47.25 (1200.15)
90 (2286.0)	20	20	20	20	47.25 (1200.15)
92 (2336.8)	20	20	20	20	47.25 (1200.15)
94 (2387.6)	20	20	20	20	47.25 (1200.15)
96 (2438.4)	20	20	20	20	47.25 (1200.15)
98 (2489.2)	20	20	20	20	47.25 (1200.15)
100 (2540.0)	20	20	20	20	47.25 (1200.15)
102 (2590.8)	20	20	20	20	47.25 (1200.15)
104 (2641.6)	20	20	20	20	47.25 (1200.15)
106 (2692.4)	20	20	20	20	47.25 (1200.15)
108 (2743.2)	20	20	20	20	47.25 (1200.15)
110 (2794.0)	20	20	20	20	47.25 (1200.15)
112 (2844.8)	20	20	20	20	47.25 (1200.15)
114 (2895.6)	20	20	20	20	47.25 (1200.15)
116 (2946.4)	20	20	20	20	47.25 (1200.15)
118 (2997.2)	20	20	20	20	47.25 (1200.15)
120 (3048.0)	14	14	14	14	46.75 (1187.45)

DUCT DIA "D"	-6" WG (-1,495 Pa)	-10" WG (-2,491 Pa)	-14" WG (-3,487 Pa)	-18" WG (-4,484 Pa)	STD DUCT LENGTH
8 (203.2)					
10 (254.0)					
12 (304.8)					
14 (355.6)					
16 (406.4)					
18 (457.2)					
20 (508.0)	20	20	20	20	
22 (558.8)	20	20	20	20	
24 (609.6)	20	20	20	20	
26 (660.4)	20	20	20	20	
28 (711.2)	20	20	20	20	
30 (762.0)	20	20	20	20	
32 (812.8)	20	20	20	20	
34 (863.6)	20	20	20	20	
36 (914.4)	20	20	20	20	
38 (965.2)	20	20	20	20	
40 (1016.0)	20	20	20	20	
42 (1066.8)	20	20	20	20	
44 (1117.6)	20	20	20	20	
46 (1168.4)	20	20	20	20	
48 (1219.2)	20	20	20	20	
50 (1270.0)	20	20	20	20	
52 (1320.8)	20	20	20	20	
54 (1371.6)	20	20	20	20	
56 (1422.4)	20	20	20	20	
58 (1473.2)	20	20	20	20	
60 (1524.0)	20	20	20	20	
62 (1574.8)	20	20	20	20	
64 (1625.6)	20	20	20	20	
66 (1676.4)	20	20	20	20	
68 (1727.2)	20	20	20	20	
70 (1778.0)	20	20	20	20	
72 (1828.8)	20	20	20	20	
74 (1879.6)	20	20	20	20	
76 (1930.4)	20	20	20	20	
78 (1981.2)	20	20	20	20	
80 (2032.0)	20	20	20	20	
82 (2082.8)	20	20	20	20	
84 (2133.6)	20	20	20	20	
86 (2184.4)	20	20	20	20	
88 (2235.2)	20	20	20	20	
90 (2286.0)	20	20	20	20	
92 (2336.8)	20	20	20	20	
94 (2387.6)	20	20	20	20	
96 (2438.4)	20	20	20	20	
98 (2489.2)	20	20	20	20	
100 (2540.0)	20	20	20	20	
102 (2590.8)	20	20	20	20	
104 (2641.6)	20	20	20	20	
106 (2692.4)	20	20	20	20	
108 (2743.2)	20	20	20	20	
110 (2794.0)	20	20	20	20	
112 (2844.8)	20	20	20	20	
114 (2895.6)	20	20	20	20	
116 (2946.4)	20	20	20	20	
118 (2997.2)	20	20	20	20	
120 (3048.0)	12	12	12	12	94.75 (2406.65)

METRIC EQUIVALENTS ARE SHOWN IN PARENTHESIS & ITALICS (MILLIMETERS OR AS NOTED)

Ring Mechanical Specifications

DUCT DIA D	ANGLE RING SPECIFICATIONS					RING MATERIAL & GASKETS			CAST RING SPECIFICATIONS														
	WIDTH (W)	THICKNESS (T)	# HOLES	BOLT HOLE SIZE	BOLT SIZE	BOLT CIRCLE DIA.	PTFE GASKET W x H	STAINLESS STEEL	BLACK IRON	DUCT DIA	WIDTH (W)	HEIGHT (H)	THICKNESS (T)	# HOLES	BOLT HOLE SIZE	BOLT SIZE	BOLT CIRCLE DIA.						
4 (101.6)	1" (25.4)	1/8" (3.18)	6	7/16" (11.1)	3/8" (9.53)	5.31 (134.87)	GAS09 .01" x .75" (.25 x 19.05)	SC	BI	4	1-1/4" (31.8)	13/32" (10.32)	1/8" (3.18)	6	7/16" x 11/16" (11.1 x 17.5)	3/8	5.31						
6 (152.4)	1-1/4" (31.8)	1/8" (3.18)	8	7/16" x 11/16" (11.1 x 17.5)	3/8" (9.53)	7.50 (190.5)				GAS03 1/4 x 3/16 (6.35 x 4.76)	SS	BI	6	1-1/4" (31.8)	13/32" (10.32)	1/8" (3.18)	8	7/16" x 11/16" (11.1 x 17.5)	3/8	7.50			
8 (203.2)						9.50 (241.3)							10							11.50 (292.1)			
10 (254.0)	1-1/2" (38.1)	3/16" (4.76)	12	7/16" x 11/16" (11.1 x 17.5)	3/8" (9.53)	13.81 (350.77)							GAS09 .01" x .75" (.25 x 19.05)	SS	BI	12	1-1/2" (38.1)	1/2" (12.7)	3/16" (4.76)	12	9/16" x 3/4" (14.3 x 19.1)	1/2	13.81
12 (304.8)						15.81 (401.57)										14							17.76 (451.10)
14 (355.6)						17.76 (451.10)										16							19.76 (501.9)
16 (406.4)						21.76 (552.7)										18							23.88 (606.55)
18 (457.2)						23.88 (606.55)										20							25.88 (657.35)
20 (508.0)						25.88 (657.35)										22							27.88 (708.15)
22 (558.8)						27.88 (708.15)										24							29.88 (758.95)
24 (609.6)						29.88 (758.95)										26							31.88 (809.75)
26 (660.4)						31.88 (809.75)										28							33.88 (860.55)
28 (711.2)						33.88 (860.55)	30	35.88 (911.35)															
30 (762.0)						35.88 (911.35)	32	37.88 (962.15)															
32 (812.8)						40.38 (1025.65)	34	42.38 (1076.45)															
34 (863.6)	42.38 (1076.45)	36	44.38 (1127.25)																				
36 (914.4)	44.38 (1127.25)	38	46.38 (1178.05)																				
38 (965.2)	46.38 (1178.05)	40	48.38 (1228.85)																				
40 (1016.0)	48.38 (1228.85)	42	50.38 (1279.65)																				
42 (1066.8)	50.38 (1279.65)	44	52.88 (1343.15)																				
44 (1117.6)	52.88 (1343.15)	46	54.88 (1393.95)																				
46 (1168.4)	54.88 (1393.95)	48	56.88 (1444.75)																				
48 (1219.2)	56.88 (1444.75)	50	58.88 (1495.55)																				
50 (1270.0)	58.88 (1495.55)	52	60.88 (1546.35)																				
52 (1320.8)	60.88 (1546.35)	54	62.88 (1597.15)																				
54 (1371.6)	62.88 (1597.15)	56	64.88 (1647.95)																				
56 (1422.4)	64.88 (1647.95)	58	66.88 (1698.75)																				
58 (1473.2)	66.88 (1698.75)	60	68.88 (1749.55)																				
60 (1524.0)	68.88 (1749.55)	62	70.88 (1800.35)																				
62 (1574.8)	70.88 (1800.35)	64	72.88 (1851.15)																				
64 (1625.6)	72.88 (1851.15)	66	74.88 (1901.95)																				
66 (1676.4)	74.88 (1901.95)	68	76.88 (1952.75)																				
68 (1727.2)	76.88 (1952.75)	70	78.88 (2003.55)																				
70 (1778.0)	78.88 (2003.55)	72	80.88 (2054.35)																				
72 (1828.8)	80.88 (2054.35)	74	82.88 (2105.15)																				
74 (1879.6)	82.88 (2105.15)	76	84.88 (2155.95)																				
76 (1930.4)	84.88 (2155.95)	78	86.88 (2206.75)																				
78 (1981.2)	86.88 (2206.75)	80	89.38 (2270.25)																				
80 (2032.0)	89.38 (2270.25)	82	91.38 (2321.05)																				
82 (2082.8)	91.38 (2321.05)	84	93.38 (2371.85)																				
84 (2133.6)	93.38 (2371.85)	86	95.38 (2422.65)																				
86 (2184.4)	95.38 (2422.65)	88	97.38 (2473.45)																				
88 (2235.2)	97.38 (2473.45)	90	100.38 (2549.65)																				
90 (2286.0)	100.38 (2549.65)	92	102.38 (2600.45)																				
92 (2336.8)	102.38 (2600.45)	94	104.38 (2651.25)																				
94 (2387.6)	104.38 (2651.25)	96	106.38 (2702.05)																				
96 (2438.4)	106.38 (2702.05)	98	108.38 (2752.85)																				
98 (2489.2)	108.38 (2752.85)	100	110.38 (2803.65)																				
100 (2540.0)	110.38 (2803.65)	102	112.38 (2854.45)																				
102 (2590.8)	112.38 (2854.45)	104	114.38 (2905.25)																				
104 (2641.6)	114.38 (2905.25)	106	116.38 (2956.05)																				
106 (2692.4)	116.38 (2956.05)	108	118.38 (3006.85)																				
108 (2743.2)	118.38 (3006.85)	110	120.38 (3057.65)																				
110 (2794.0)	120.38 (3057.65)	112	122.38 (3108.45)																				
112 (2844.8)	122.38 (3108.45)	114	124.38 (3159.25)																				
114 (2895.6)	124.38 (3159.25)	116																					
116 (2946.4)																							
118 (2997.2)																							
120 (3048.0)																							

- NOTES:**
- DUCT 4" (101.6) TO 14" (355.6) MANUFACTURED WITH CAST RINGS AS STANDARD. DUCT 16" (406.4) TO 120" (3048.0) MANUFACTURED WITH ANGLE RINGS AS STANDARD.
 - STANDARD MOUNTING HOLE LOCATIONS FOR WELDED ANGLE RINGS [32" (812.8) TO 120" (3048.0)] STRADDLE THE VERTICAL CENTERLINE UNLESS OTHERWISE SPECIFIED.
 - STANDARD HARDWARE PROVIDED FOR ANGLE RING APPLICATIONS ARE PLATED GRADE 5 FASTENERS. STAINLESS STEEL HARDWARE IS NOT RECOMMENDED.
 - 1 OPTION:** CUSTOM ANGLE RINGS AVAIL
 - DUCT AND FITTINGS GREATER THAN 84" DIA. (2133.6) REQUIRES FAB-TECH ENGINEERING REVIEW AND APPROVAL.

Grade 5 Bolt Markings:

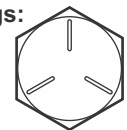

Torque Specifications:
Torque in at least 3 stages

Duct Dia.	Bolt Size	Bolt Mat'l	Ft lb	In lb	Nm
4"-10" (101.4-254.0)	3/8" (9.53)	Gr.5	35	420	48
		*SS	25	300	34
**12-14" (304.8-355.6)	3/8" (9.53)	Gr.5	35	420	48
		*SS	25	300	34
12"-120" (304.8-3048.0)	1/2" (12.7)	Gr.5	65	780	88
		*SS	60	720	82

* STAINLESS STEEL HARDWARE REQUIRES APPLICATION OF ANTI-SEIZE LUBRICANT PRIOR TO ASSEMBLY. LOCKTITE LB771 OR EQUAL.
 ** REQUIRED FOR RINGS WITH 7/16" DIAMETER BOLT HOLES.

PTFE GASKETS* FOR RING JOINTS

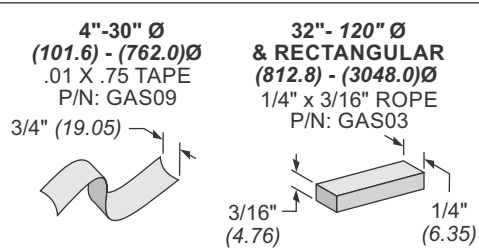

4"-30" Ø (101.6) - (762.0) Ø
 .01 X .75 TAPE
 P/N: GAS09
 3/4" (19.05)

32"- 120" Ø & RECTANGULAR (812.8) - (3048.0) Ø
 1/4" x 3/16" ROPE
 P/N: GAS03
 3/16" (4.76) 1/4" (6.35)

* ADHESIVE ON ONE SIDE

METRIC EQUIVALENTS ARE SHOWN IN PARENTHESIS & ITALICS (MILLIMETERS OR AS NOTED)

Ring Mechanical Specifications

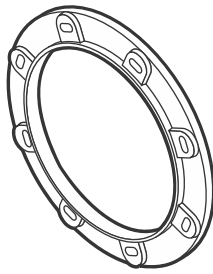

Cast Ring

STANDARD FOR DUCT 4" (101.6) TO 14" (355.6)

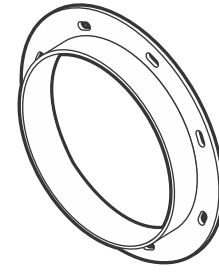
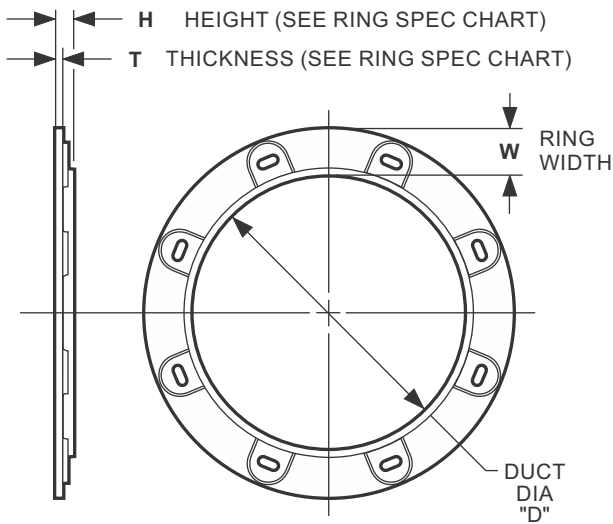

Angle Ring

BLACK IRON ANGLE RING 4" (101.6) TO 100" (2540.0)
 STAINLESS STEEL ANGLE RING 16" (406.4) TO 120" (3048.0)

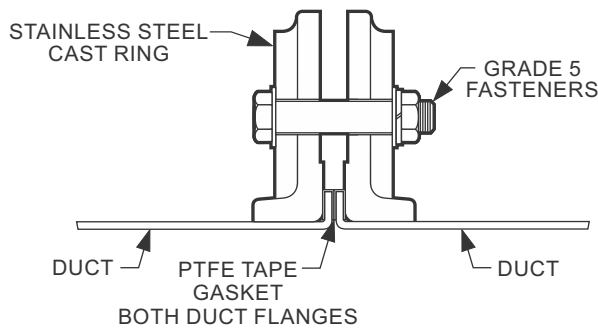
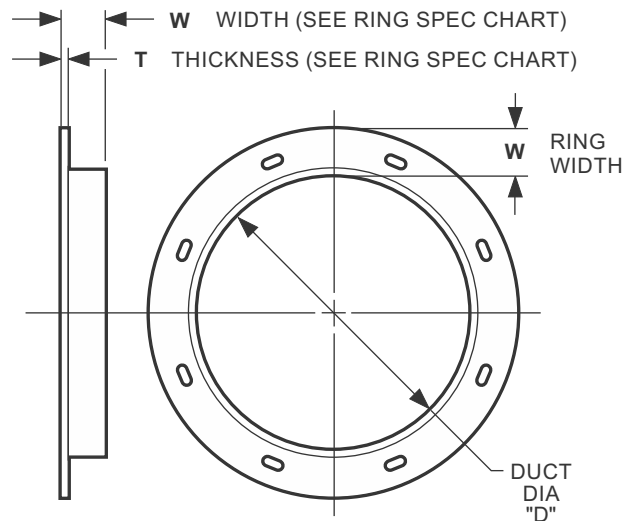

Floating Cast Ring

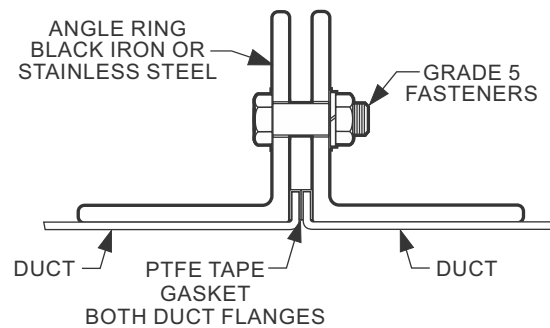

Floating Angle Ring

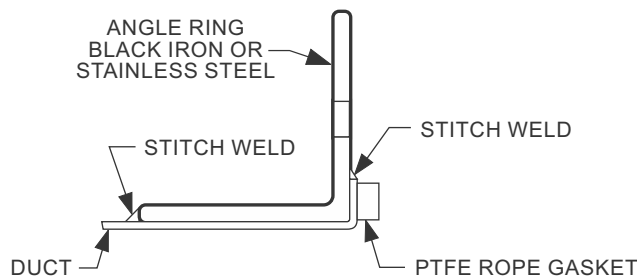

Stitch Welded Angle Ring

METRIC EQUIVALENTS ARE SHOWN IN PARENTHESIS & ITALICS (MILLIMETERS OR AS NOTED)

Joint Sealant Specifications

Technical Specifications:

► **Material:** 100% expanded PTFE (polytetrafluoroethylene), with monodirectional strength. This product is supplied with an adhesive backer only to aid in the product installation.

► **Operating Range:** The maximum applicable pressure and temperature depend mainly on the equipment and installation.

Typical use: -76°F to 300°F (-60°C to 150°C); industrial full vacuum [absolute pressure of 0.019 psi (1 mmHg(Torr) = 133 Pa = 1.33 mbar)] to 145psi (10 bar).

► **Chemical Resistance:** Chemical resistance to all media pH 0-14, except molten alkali metals and elemental fluorine.

► **Shelf Life:** ePTFE is not subject to aging and can be stored indefinitely. To ensure optimal adhesive function, we recommend use within two years of date of purchase when stored under normal conditions [70°F (21°C)] 50% Relative Humidity).

PTFE GASKETS* FOR RING JOINTS

4" - 30" (101.6 - 762.0) Ø
.01 X .75 TAPE
P/N: GAS09

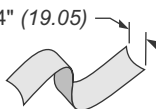

32" - 120" (812.8 - 3048.0) Ø
& RECTANGULAR
1/4" x 3/16" ROPE
P/N: GAS03

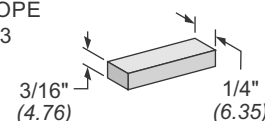

* ADHESIVE ON ONE SIDE

FOR INDUSTRIAL USE ONLY: Not for use in food, drug, cosmetic or medical device manufacturing, processing, or packaging operations.

Safety Information:

► **Regulatory Information:** The gasket products supplied as a finished part in the form of spooled cord for use on PermaShield Pipe duct fittings meet the definition of an article in the United States, per OSHA Regulation 29 CFR 1910.1200(b)(6)(v) during normal intended use, and as described in EC Regulation 1907/2006/EC. These products also meet the definition of an article in the Australian Approved Criteria For Classifying Hazardous Substances [NOHSC: 1008(2004)] 3rd edition, October 2004 and of a manufactured article under Section 12 of the Canadian Hazardous Product Act. For this reason, a Material Safety Data Sheet (MSDS) or Safety Data Sheet (SDS) is not required.

► **Risks and Usage Recommendations:** These materials are non-hazardous in their original form and when applied properly. Do not heat over 600°F (315°C) and avoid burning, grinding and melting of the product. If the material is being cut or removed using burning, grinding or elevated temperature processes, or if it is involved in a fire situation, hazardous decomposition byproducts may form, including: carbon monoxide, carbon dioxide, hydrogen fluoride, carbonyl fluoride, tetrafluoroethylene, perfluoroisobutylene, and traces of incompletely burned carbon products. Inhalation of fumes from overheating or burning of this product may cause polymer fume fever, a flu-like illness with chills and fever.

► **Control Measures:** The risks from exposure can be reduced if standard practices are used. These practices include:

- 1) Not heating product over 600°F (315°C).
- 2) Avoid burning, grinding, high temperature cutting or melting of the product without the use of effective local exhaust ventilation and/or personal protective equipment.
- 3) Protecting material from fire. In the event of a fire wear self-contained breathing apparatus and wear full protective equipment. Hydrogen fluoride fumes emitted during a fire can react with water to form hydrofluoric acid. Wear neoprene gloves when handling refuse from a fire.
- 4) Dispose of according to local, state, national, and international regulations. Incinerate only if incinerator is capable of scrubbing out hydrogen fluoride and other acidic combustion products.

KEY: **SC** STAINLESS CAST RING
SS STAINLESS STEEL ANGLE RING
BI BLACK IRON ANGLE RING

DUCT DIA "D"	RING MATERIAL & GASKETS	
	PTFE GASKET W x H	STAINLESS STEEL BLACK IRON
4 (101.6)	GAS09 .01" x .75" (.25 x 19.05)	SC
6 (152.4)		SC
8 (203.2)		SC
10 (254.0)		SC
12 (304.8)		SC
14 (355.6)		SC
16 (406.4)		SC
18 (457.2)		SC
20 (508.0)		SC
22 (558.8)		SC
24 (609.6)		SC
26 (660.4)		SC
28 (711.2)		SC
30 (762.0)		SC
32 (812.8)	SC	
34 (863.6)	SC	
36 (914.4)	SC	
38 (965.2)	GAS03 1/4 x 3/16 (6.35 x 4.76)	BI
40 (1016.0)		BI
42 (1066.8)		BI
44 (1117.6)		BI
46 (1168.4)		BI
48 (1219.2)		BI
50 (1270.0)		BI
52 (1320.8)		BI
54 (1371.6)		BI
56 (1422.4)		BI
58 (1473.2)		BI
60 (1524.0)		BI
62 (1574.8)		BI
64 (1625.6)		BI
66 (1676.4)	BI	
68 (1727.2)	BI	
70 (1778.0)	BI	
72 (1828.8)	BI	
74 (1879.6)	BI	
76 (1930.4)	BI	
78 (1981.2)	BI	
80 (2032.0)	BI	
82 (2082.8)	BI	
84 (2133.6)	BI	
86 (2184.4)	BI	
88 (2235.2)	BI	
90 (2286.0)	BI	
92 (2336.8)	BI	
94 (2387.6)	BI	
96 (2438.4)	BI	
98 (2489.2)	BI	
100 (2540.0)	BI	
102 (2590.8)	BI	
104 (2641.6)	BI	
106 (2692.4)	BI	
108 (2743.2)	BI	
110 (2794.0)	BI	
112 (2844.8)	BI	
114 (2895.6)	BI	
116 (2946.4)	BI	
118 (2997.2)	BI	
120 (3048.0)	BI	

METRIC EQUIVALENTS ARE SHOWN IN PARENTHESIS & ITALICS (MILLIMETERS OR AS NOTED)

Gasket Placement For Dissimilar Duct Joint Connections

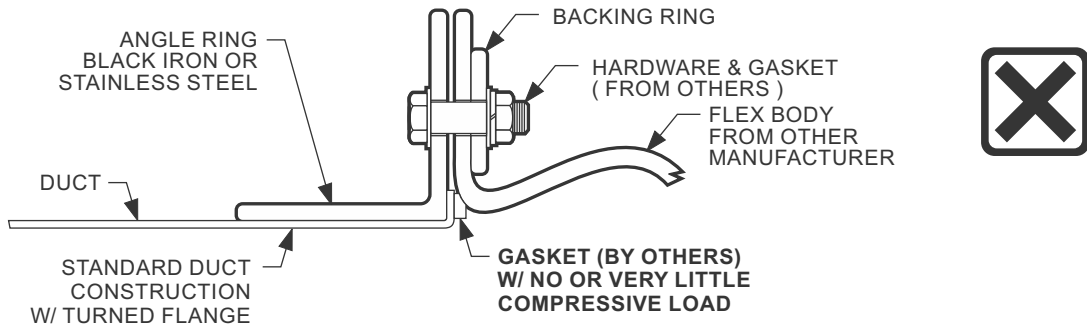

Incorrect Flex/Expansion Joint Connection

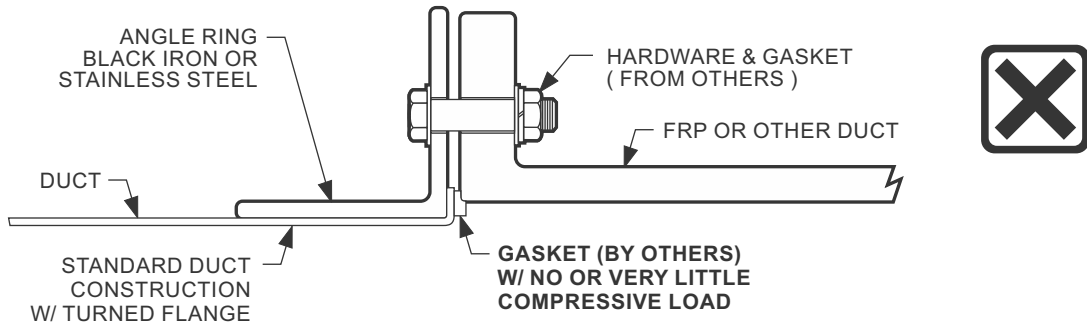

Incorrect FRP or Other Duct Joint Connection

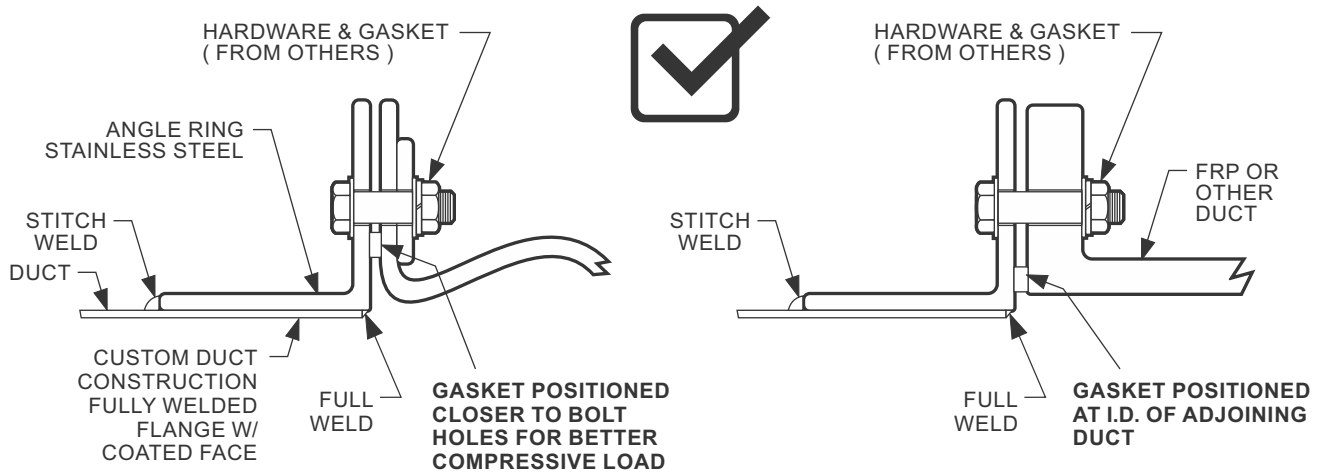

Correct Gasket Placement For Dissimilar Duct Joint Connections

METRIC EQUIVALENTS ARE SHOWN IN PARENTHESIS & ITALICS (MILLIMETERS OR AS NOTED)

PSP-EZ™ Clamp Mechanical Specifications

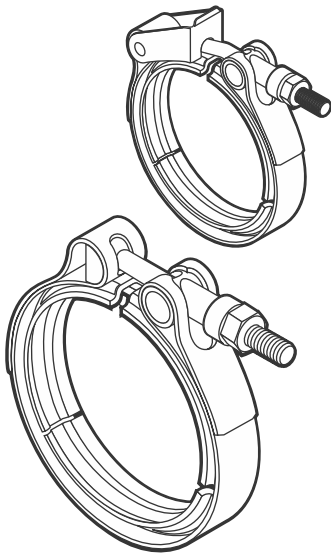

DUCT DIA. "D"	DUCT GAUGE -6" Thru -18" WG	STRAIGHT DUCT LENGTH	BACKING RING
2 (50.8)	.035 (0.89) TUBING	4 FT	WELDED
3 (76.2)	.065 (1.65) TUBING		
4 (101.6)	20ga 0.0375 (0.95)	47.25" (1200.15) ACTUAL	FLOATING
6 (152.4)			
8 (203.2)			
10 (254.0)			
12 (304.8)			
14 (355.6)			

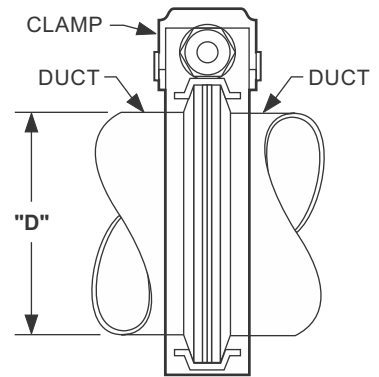

The PSP-EZ™ joining system is available for standard PermaShielded duct from 2" (50.8) to 14" (355.6) in diameter. The combination of half round backing rings and the unique angled clamp band provides excellent clamping force with the added benefit of ease of installation.

Duct Diameter	Bolt Size	Torque Specifications: Torque in at least 3 stages		
		lb*ft	lb*in	kg*m
2" (50.4)	1/4" (6.35)	6.25	75	0.9
3" (76.2)				
4" (101.6)				
6" (152.4)				
8" (203.2)	5/16" (7.94)	10	120	1.4
10" (254.0)				
12" (304.8)				
14" (355.6)				

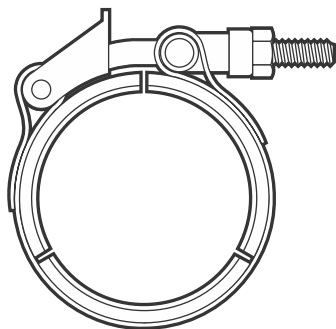
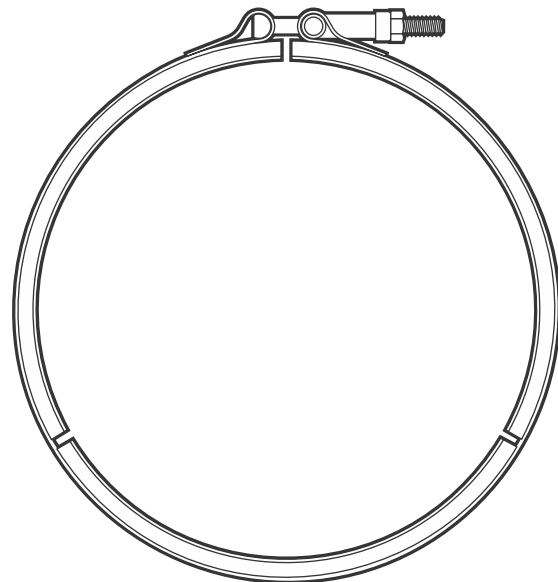

2" (50.8) & 3" (76.2) PSP-EZ™ CLAMP

4" (101.6) - 14" (355.6) PSP-EZ™ CLAMP

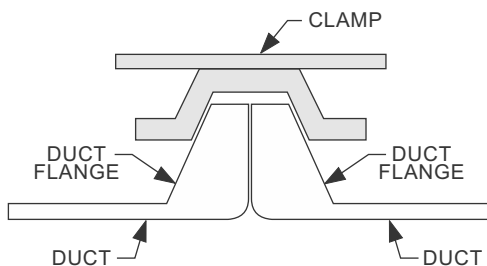

CROSS SECTION OF JOINT

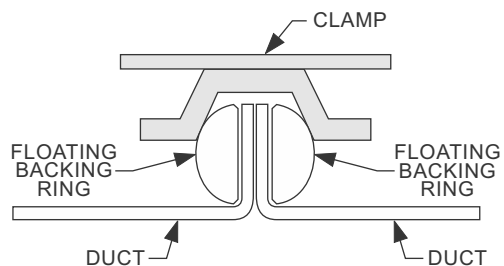

CROSS SECTION OF JOINT

METRIC EQUIVALENTS ARE SHOWN IN PARENTHESIS & ITALICS (MILLIMETERS OR AS NOTED)

Conversion Chart - Imperial to Metric

DUCT DIA			DUCT DIA		
Order Size	English Equivalent	Actual Size	Order Size	English Equivalent	Actual Size
50mm	2"	50.8mm	1550mm	62"	1574.8mm
100mm	4"	101.6mm	1600mm	64"	1625.6mm
150mm	6"	152.4mm	1650mm	66"	1676.4mm
200mm	8"	203.2mm	1700mm	68"	1727.2mm
250mm	10"	254.0mm	1750mm	70"	1778.0mm
300mm	12"	304.8mm	1800mm	72"	1828.8mm
350mm	14"	355.6mm	1850mm	74"	1879.6mm
400mm	16"	406.4mm	1900mm	76"	1930.4mm
450mm	18"	457.2mm	1950mm	78"	1981.2mm
500mm	20"	508.0mm	2000mm	80"	2032.0mm
550mm	22"	558.8mm	2050mm	82"	2082.8mm
600mm	24"	609.6mm	2100mm	84"	2133.6mm
650mm	26"	660.4mm	2150mm	86"	2184.4mm
700mm	28"	711.2mm	2200mm	88"	2235.2mm
750mm	30"	762.0mm	2250mm	90"	2286.0mm
800mm	32"	812.8mm	2300mm	92"	2336.8mm
850mm	34"	863.6mm	2350mm	94"	2387.6mm
900mm	36"	914.4mm	2400mm	96"	2438.4mm
950mm	38"	965.2mm	2450mm	98"	2489.2mm
1000mm	40"	1016.0mm	2500mm	100"	2540.0mm
1050mm	42"	1066.8mm	2550mm	102"	2590.8mm
1100mm	44"	1117.6mm	2600mm	104"	2641.6mm
1150mm	46"	1168.4mm	2650mm	106"	2692.4mm
1200mm	48"	1219.2mm	2700mm	108"	2743.2mm
1250mm	50"	1270.0mm	2750mm	110"	2794.0mm
1300mm	52"	1320.8mm	2800mm	112"	2844.8mm
1350mm	54"	1371.6mm	2850mm	114"	2895.6mm
1400mm	56"	1422.4mm	2900mm	116"	2946.4mm
1450mm	58"	1473.2mm	3950mm	118"	2997.2mm
1500mm	60"	1524.0mm	3000mm	120"	3048.0mm

- METRIC CONVERSIONS ARE ROUNDED TO THE MOST APPROPRIATE EVEN INCH UNLESS OTHERWISE SPECIFIED
- DUCT AND FITTINGS GREATER THAN 84" DIAMETER REQUIRES ENGINEERING REVIEW AND APPROVAL

METRIC EQUIVALENTS ARE SHOWN IN PARENTHESIS & ITALICS (MILLIMETERS OR AS NOTED)

Weight Chart - Coated EZ Duct / Miscellaneous Fittings

DUCT DIA "D" in (mm)	Single Van Stone Ring lbs (kg)	End Cap w/ Van Stone Ring lbs (kg)	Damper w/ Van Stone Rings Manual Operation	Blastgate w/ Van Stone Rings Manual Operation
			lbs (kg)	lbs (kg)
4 (101.6)	1.0 (0.45)	1.3 (0.59)	4.9 (2.22)	9.8 (4.45)
6 (152.4)	1.8 (0.82)	2.4 (1.09)	8.2 (3.72)	14.3 (6.49)
8 (203.2)	2.3 (1.04)	3.2 (1.45)	10.8 (4.90)	18.2 (8.26)
10 (254.0)	2.9 (1.32)	4.2 (1.91)	13.7 (6.22)	22.4 (10.17)
12 (304.8)	6.9 (3.13)	8.7 (3.95)	22.1 (10.03)	32.1 (14.57)
14 (355.6)	7.1 (3.22)	9.4 (4.27)	26.3 (11.94)	37.5 (17.03)
16 (406.4)	8.0 (3.63)	15.1 (6.86)	100 (45.40)	42.8 (19.43)
18 (457.2)	8.9 (4.04)	17.6 (7.99)	109 (49.49)	58.6 (26.60)
20 (508.0)	9.8 (4.45)	20.2 (9.17)	118 (53.57)	65.2 (29.60)
22 (558.8)	10.8 (4.90)	22.9 (10.40)	128 (58.11)	72.6 (32.96)
24 (609.6)	11.7 (5.31)	25.8 (11.71)	138 (62.65)	80.2 (36.41)
26 (660.4)	17.4 (7.90)	33.6 (15.25)	158 (71.73)	98.3 (44.63)
28 (711.2)	18.7 (8.49)	37.2 (16.89)	170 (77.18)	107 (48.58)
30 (762.0)	19.9 (9.03)	40.8 (18.52)	182 (82.63)	117 (53.12)
32 (812.8)	21.2 (9.62)	44.6 (20.25)	194 (88.08)	127 (57.66)
34 (863.6)	22.5 (10.21)	48.5 (22.02)	234 (106.24)	136 (61.74)
36 (914.4)	23.8 (10.81)	60.0 (27.24)	221 (100.33)	146 (66.28)
38 (965.2)	25.0 (11.35)	64.6 (29.33)	235 (106.69)	326 (148.00)
40 (1016.0)	26.3 (11.94)	69.4 (31.51)	249 (113.05)	337 (152.00)
42 (1066.8)	27.6 (12.53)	74.3 (33.73)	264 (119.86)	353 (160.26)
44 (1117.6)	28.9 (13.12)	79.4 (36.05)	280 (127.12)	370 (167.98)
46 (1168.4)	30.1 (13.67)	84.6 (38.41)	296 (134.38)	385 (174.79)
48 (1219.2)	31.4 (14.26)	89.9 (40.81)	314 (142.56)	406 (184.32)
50 (1270.0)	41.4 (18.79)	120 (54.48)	517 (234.72)	460 (208.84)
52 (1320.8)	43.1 (19.57)	126 (57.20)	544 (246.98)	483 (219.28)
54 (1371.6)	44.6 (20.25)	133 (60.38)	573 (260.14)	505 (229.27)
56 (1422.4)	46.3 (21.02)	140 (63.56)	602 (273.31)	530 (240.62)
58 (1473.2)	47.8 (21.70)	147 (66.74)	633 (287.38)	553 (251.06)
60 (1524.0)	79.5 (36.09)	207 (93.98)	725 (329.15)	652 (296.01)
62 (1574.8)	82.0 (37.23)	216 (98.06)	757 (343.68)	672 (305.09)
64 (1625.6)	84.6 (38.41)	225 (102.15)	791 (359.11)	696 (315.98)
66 (1676.4)	87.1 (39.54)	235 (106.69)	826 (375.00)	720 (326.88)
68 (1727.2)	89.7 (40.72)	244 (110.78)	861 (390.89)	750 (340.50)
70 (1778.0)	92.9 (42.18)	254 (115.32)	897 (407.24)	800 (363.20)
72 (1828.8)	94.8 (43.04)	263 (119.40)	936 (424.94)	816 (370.46)
74 (1879.6)	97.4 (44.22)	273 (123.94)	972 (441.29)	832 (377.73)
76 (1930.4)	100 (45.40)	283 (128.48)	1010 (458.54)	848 (384.99)
78 (1981.2)	102 (46.31)	293 (133.02)	1051 (477.15)	864 (392.26)
80 (2032.0)	105 (47.67)	304 (138.02)	1089 (494.41)	885 (401.79)
82 (2082.8)	108 (49.03)	314 (142.56)	1129 (512.57)	902 (409.51)
84 (2133.6)	110 (49.94)	325 (147.55)	1171 (531.63)	923 (419.04)
86 (2184.4)	113 (51.30)	336 (152.54)		
88 (2235.2)	115 (52.21)	347 (157.54)		
90 (2286.0)	118 (53.57)	358 (162.53)		
92 (2336.8)	120 (54.48)	369 (167.53)		
94 (2387.6)	123 (55.84)	380 (172.52)		
96 (2438.4)	171 (77.63)	437 (198.40)		
98 (2489.2)	174 (78.99)	450 (204.30)		
100 (2540.0)	178 (80.81)	463 (210.20)		
102 (2590.8)	181 (82.17)	475 (215.65)		
104 (2641.6)	185 (83.99)	488 (221.55)		
106 (2692.4)	188 (85.35)	502 (227.91)		
108 (2743.2)	192 (87.17)	515 (233.81)		
110 (2794.0)	195 (88.53)	528 (239.71)		
112 (2844.8)	199 (90.35)	542 (246.07)		
114 (2895.6)	202 (91.71)	555 (251.97)		
116 (2946.4)	206 (93.52)	569 (258.33)		
118 (2997.2)	209 (94.89)	583 (264.68)		
120 (3048.0)	213 (96.70)	598 (271.49)		

NOTES:

1. ALL WEIGHTS ARE CALCULATED, HARDWARE NOT INCLUDED.
2. SOME WEIGHTS FOR FITTINGS LARGER THAN 20" (508.0) DIAMETER HAVE BEEN ROUNDED TO THE NEAREST POUND.
3. TO CALCULATE THE APPROXIMATE WEIGHT FOR CUSTOM LENGTH DUCT OR FOR FITTINGS SUCH AS REDUCERS, USE THE PER FOOT WEIGHT FOR STRAIGHT DUCT IN THE PROPER PRESSURE CLASS.

EZ Duct Weight Charts

DUCT DIA "D" in (mm)	Duct Per Foot lbs (kg)	4' Duct lbs (kg)	Single Clamp lbs (kg)
4 (101.6)	1.8 (.817)	7.2 (3.27)	0.4 (.182)
6 (152.4)	2.7 (1.23)	10.9 (4.95)	0.6 (.272)
8 (203.2)	3.6 (1.63)	14.5 (6.58)	1.2 (.545)
10 (254.0)	4.5 (2.04)	18.1 (8.22)	1.4 (.636)
12 (304.8)	5.4 (2.45)	21.7 (9.85)	1.8 (.817)
14 (355.6)	6.3 (2.86)	25.5 (11.58)	2.0 (.908)

DUCT DIA "D" in (mm)	90° Elbow	
	R=1.5D lbs (kg)	R=1D lbs (kg)
4 (101.6)	2.2 (.999)	1.5 (.681)
6 (152.4)	4.5 (2.04)	3.5 (1.59)
8 (203.2)	8.3 (3.77)	6.4 (2.91)
10 (254.0)	11.9 (5.40)	9.0 (4.09)
12 (304.8)	15.1 (6.86)	10.9 (4.95)
14 (355.6)	21.7 (9.85)	16.0 (7.26)

DUCT DIA "D" in (mm)	Damper	Blastgate	End Cap
	lbs (kg)	lbs (kg)	lbs (kg)
4 (101.6)	3.1 (1.41)	7.0 (3.18)	1.0 (.454)
6 (152.4)	4.8 (2.18)	9.5 (4.31)	1.6 (.726)
8 (203.2)	6.4 (2.91)	12.7 (5.77)	2.6 (1.18)
10 (254.0)	8.1 (3.68)	15.0 (6.81)	3.5 (1.59)
12 (304.8)	10.3 (4.68)	17.9 (8.13)	4.4 (1.99)
14 (355.6)	12.6 (5.72)	21.0 (9.53)	5.4 (2.45)

DUCT DIA "D" in (mm)	60° Elbow		45° Elbow		30° Elbow	
	R=1.5D lbs (kg)	R=1D lbs (kg)	R=1.5D lbs (kg)	R=1D lbs (kg)	R=1.5D lbs (kg)	R=1D lbs (kg)
4 (101.6)	1.2 (.545)	0.8 (.363)	0.9 (.409)	0.6 (.272)	0.7 (.318)	0.4 (.182)
6 (152.4)	2.4 (1.09)	1.7 (.772)	1.9 (.863)	1.4 (.636)	1.4 (.636)	1.0 (.454)
8 (203.2)	4.0 (1.82)	2.9 (1.32)	3.1 (1.41)	2.3 (1.04)	2.3 (1.04)	1.7 (.772)
10 (254.0)	6.0 (2.72)	4.3 (1.95)	4.7 (2.13)	3.8 (1.73)	3.4 (1.54)	2.7 (1.23)
12 (304.8)	8.5 (3.86)	6.0 (2.72)	6.6 (2.99)	4.7 (2.13)	4.7 (2.13)	3.4 (1.54)
14 (355.6)	11.3 (5.13)	7.9 (3.59)	8.8 (3.99)	6.2 (2.81)	6.3 (2.86)	4.5 (2.04)

METRIC EQUIVALENTS ARE SHOWN IN PARENTHESIS & ITALICS (MILLIMETERS OR AS NOTED)

Weight Chart - Coated Straight Duct & Elbows: -10" Wg Pressure Class











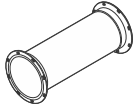

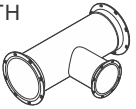
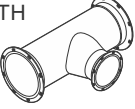
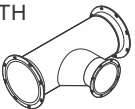
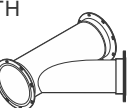
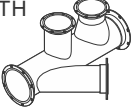
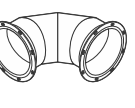

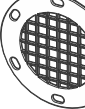
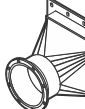

DUCT DIA "D" in (mm)	Per Foot 1' - 4'		4' Duct w/ Van Stone Rings lb (kg)	Per Foot 4' - 8'	8' Duct w/ Van Stone Rings lb (kg)	30° Elbow		45° Elbow		60° Elbow		90° Elbow	
	lb (kg)	lb (kg)				R=1.5D lb (kg)	R=1D lb (kg)	R=1.5D lb (kg)	R=1D lb (kg)	R=1.5D lb (kg)	R=1D lb (kg)	R=1.5D lb (kg)	R=1D lb (kg)
4	101.6	1.7 0.8	9.0 4.1			2.6 1.2	2.1 1.0	2.8 1.3	2.3 1.0	3.0 1.4	2.6 1.2	3.4 1.5	2.9 1.3
6	152.4	2.6 1.2	14.2 6.4			5.0 2.3	4.6 2.1	5.5 2.5	4.9 2.2	6.0 2.7	5.3 2.4	7.0 3.2	5.9 2.7
8	203.2	3.5 1.6	18.8 8.5	3.5 1.6	32.9 14.9	7.4 3.4	6.4 2.9	8.2 3.7	6.9 3.1	9.2 4.2	7.7 3.5	10.7 4.9	8.9 4.0
10	254.0	4.4 2.0	23.6 10.7	4.4 2.0	41.3 18.8	9.7 4.4	8.4 3.8	10.9 4.9	9.0 4.1	12.3 5.6	10.1 4.6	14.4 6.5	11.9 5.4
12	304.8	5.3 2.4	35.2 16.0	5.3 2.4	56.5 25.7	17.7 8.1	15.8 7.2	19.6 8.9	16.8 7.6	21.5 9.8	18.5 8.4	25.3 11.5	21.0 9.5
14	355.6	6.2 2.8	39.2 17.8	6.2 2.8	64.1 29.1	22.0 10.0	19.2 8.7	24.8 11.3	20.7 9.4	27.6 12.5	23.2 10.5	33.2 15.1	26.8 12.2
16	406.4	7.1 3.2	44.6 20.2	7.1 3.2	73.1 33.2	26.4 12.0	22.4 10.2	30.0 13.6	24.6 11.2	33.7 15.3	27.9 12.7	41.1 18.7	32.6 14.8
18	457.2	8.0 3.6	50.0 22.7	8.0 3.6	82.1 37.3	30.7 13.9	26.0 11.8	35.2 16.0	28.5 12.9	39.8 18.1	32.7 14.8	49.0 22.2	38.4 17.4
20	457.2	8.9 4.0	55.4 25.2	8.9 4.0	91.1 41.4	35.1 15.9	29.7 13.5	40.4 18.3	32.4 14.7	45.9 20.8	37.4 17.0	56.9 25.8	44.2 20.1
22	558.8	9.8 4.4	61.0 27.7	12.6 5.7	122.4 55.6	39.4 17.9	33.6 15.3	45.6 20.7	36.3 16.5	52.0 23.6	42.1 19.1	64.8 29.4	50.0 22.7
24	609.6	10.6 4.8	65.7 29.8	13.7 6.2	133.4 60.6	44.7 20.3	37.8 17.2	52.0 23.6	42.7 19.4	59.4 27.0	47.6 21.6	74.5 33.8	57.6 26.2
26	660.4	11 5.0	81 36.8	15 6.8	154 69.9	60 27.2	51 23.2	69 31.3	57 25.9	77 35.0	63 28.6	95 43.1	75 34.1
28	711.2	12 5.4	87 39.5	16 7.3	163 74.0	67 30.4	57 25.9	77 35.0	63 28.6	87 39.5	70 31.8	107 48.6	84 38.1
30	762.0	13 5.9	93 42.2	17 7.7	177 80.4	73 33.1	62 28.1	85 38.6	70 31.8	96 43.6	78 35.4	120 54.5	93 42.2
32	812.8	14 6.4	99 44.9	18 8.2	187 84.9	93 42.2	76 34.5	111 50.4	85 38.6	128 58.1	101 45.9	164 74.5	123 55.8
34	863.6	15 6.8	105 47.7	19 8.6	198 89.9	102 46.3	83 37.7	122 55.4	93 42.2	141 64.0	111 50.4	181 82.2	135 61.3
36	914.4	20 9.1	126 57.2	28 12.7	273 123.9	111 50.4	90 40.9	133 60.4	101 45.9	154 69.9	121 54.9	198 89.9	147 66.7
38	965.2	21 9.5	133 60.4	30 13.6	292 132.6	120 54.5	97 44.0	144 65.4	109 49.5	167 75.8	131 59.5	215 97.6	159 72.2
40	1016.0	22 10.0	139 63.1	32 14.5	310 140.7	125 56.8	101 45.9	152 69.0	119 54.0	179 81.3	137 62.2	234 106.2	174 79.0
42	1066.8	23 10.4	146 66.3	34 15.4	329 149.4	135 61.3	109 49.5	165 74.9	128 58.1	195 88.5	148 67.2	256 116.2	189 85.8
44	1117.6	24 10.9	153 69.5	36 16.3	348 158.0	146 66.3	116 52.7	178 80.8	138 62.7	211 95.8	161 73.1	278 126.2	205 93.1
46	1168.4	25 11.4	159 72.2	38 17.3	366 166.2	156 70.8	125 56.8	191 86.7	149 67.6	227 103.1	173 78.5	300 136.2	222 100.8
48	1219.2	26 11.8	166 75.4	40 18.2	385 174.8	167 75.8	133 60.4	206 93.5	159 72.2	245 111.2	185 84.0	325 147.6	238 108.1
50	1270.0	27 12.3	190 86.3	42 19.1	421 191.1	197 89.4	160 72.6	239 108.5	188 85.4	281 127.6	216 98.1	368 167.1	274 124.4
52	1320.8	28 12.7	197 89.4	44 20.0	440 199.8	234 106.2	186 84.4	291 132.1	216 98.1	349 158.4	262 118.9	466 211.6	341 154.8
54	1371.6	29 13.2	204 92.6	49 22.2	481 218.4	249 113.0	197 89.4	310 140.7	229 104.0	373 169.3	279 126.7	498 226.1	364 165.3
56	1422.4	30 13.6	211 95.8	51 23.2	500 227.0	264 119.9	208 94.4	329 149.4	242 109.9	397 180.2	296 134.4	530 240.6	387 175.7
58	1473.2	46 20.9	279 126.7	53 24.1	519 235.6	279 126.7	220 99.9	350 158.9	267 121.2	421 191.1	315 143.0	567 257.4	412 187.0
60	1524.0	48 21.8	351 159.4	55 25.0	599 271.9	356 161.6	292 132.6	431 195.7	342 155.3	508 230.6	393 178.4	664 301.5	497 225.6
62	1574.8	50 22.7	364 165.3	57 25.9	620 281.5	374 169.8	306 138.9	454 206.1	360 163.4	536 243.3	414 188.0	703 319.2	525 238.4
64	1625.6	52 23.6	377 171.2	59 26.8	641 291.0	392 178.0	320 145.3	478 217.0	377 171.2	565 256.5	435 197.5	743 337.3	553 251.1
66	1676.4	54 24.5	390 177.1	61 27.7	662 300.5	412 187.0	334 151.6	503 228.4	395 179.3	596 270.6	457 207.5	785 356.4	583 264.7
68	1727.2	56 25.4	403 183.0	63 28.6	683 310.1	432 196.1	349 158.4	529 240.2	414 188.0	627 284.7	480 217.9	828 375.9	613 278.3
70	1778.0	58 26.3	418 189.8	65 29.5	705 320.1	451 204.8	364 165.3	554 251.5	432 196.1	658 298.7	502 227.9	871 395.4	643 291.9
72	1828.8	60 27.2	429 194.8	67 30.4	725 329.2	540 245.2	427 193.9	676 306.9	502 227.9	820 372.3	607 275.6	1105 501.7	797 361.8
74	1879.6	62 28.1	443 201.1	69 31.3	746 338.7	564 256.1	445 202.0	707 321.0	524 237.9	859 390.0	634 287.8	1159 526.2	834 378.6
76	1930.4	64 29.1	456 207.0	71 32.2	768 348.7	588 267.0	463 210.2	738 335.1	546 247.9	898 407.7	661 300.1	1213 550.7	871 395.4
78	1981.2	66 30.0	468 212.5	101 45.9	1008 457.6	612 277.8	481 218.4	769 349.1	568 257.9	937 425.4	688 312.4	1267 575.2	908 412.2
80	2032.0	68 30.9	482 218.8	104 47.2	1038 471.3	636 288.7	499 226.5	800 363.2	590 267.9	976 443.1	715 324.6	1321 599.7	945 429.0
82	2082.8	70 31.8	496 225.2	107 48.6	1068 484.9								
84	2133.6	76 34.5	524 237.9	110 49.9	1096 497.6								
86	2184.4	78 35.4	538 244.3	113 51.3	1126 511.2								
88	2235.2	80 36.3	550 249.7	116 52.7	1154 523.9								
90	2286.0	82 37.2	564 256.1	119 54.0	1184 537.5								
92	2336.8	84 38.1	576 261.5	122 55.4	1212 550.2								
94	2387.6	86 39.0	590 267.9	125 56.8	1242 563.9								
96	2438.4	88 40.0	694 315.1	128 58.1	1362 618.3								
98	2489.2	90 40.9	708 321.4	131 59.5	1392 632.0								
100	2540.0	92 41.8	724 328.7	134 60.8	1424 646.5								
102	2590.8	94 42.7	738 335.1	137 62.2	1454 660.1								
104	2641.6	96 43.6	754 342.3	140 63.6	1486 674.6								
106	2692.4	98 44.5	768 348.7	143 64.9	1516 688.3								
108	2743.2	100 45.4	784 355.9	146 66.3	1548 702.8								
110	2794.0	102 46.3	798 362.3	149 67.6	1578 716.4								
112	2844.8	104 47.2	814 369.6	152 69.0	1610 730.9								
114	2895.6	106 48.1	828 375.9	155 70.4	1640 744.6								
116	2946.4	108 49.0	844 383.2	158 71.7	1672 759.1								
118	2997.2	110 49.9	858 389.5	161 73.1	1702 772.7								
120	3048.0	112 50.8	874 396.8	164 74.5	1734 396.8								

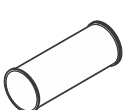
METRIC EQUIVALENTS ARE SHOWN IN PARENTHESIS & ITALICS (MILLIMETERS OR AS NOTED)

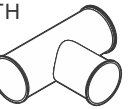
Weight Chart - Coated Straight Duct & Elbows: -14" Wg Pressure Class

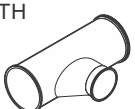
DUCT DIA "D" in (mm)	Per Foot 1' - 4'		4' Duct w/ Van Stone Rings lb (kg)	Per Foot 4' - 8'	8' Duct w/ Van Stone Rings lb (kg)	30° Elbow		45° Elbow		60° Elbow		90° Elbow	
	lb (kg)	lb (kg)				R=1.5D lb (kg)	R=1D lb (kg)	R=1.5D lb (kg)	R=1D lb (kg)	R=1.5D lb (kg)	R=1D lb (kg)	R=1.5D lb (kg)	R=1D lb (kg)
4 101.6	1.7 0.8	9.0 4.1				2.6 1.2	2.1 1.0	2.8 1.3	2.3 1.0	3.0 1.4	2.6 1.2	3.4 1.5	2.9 1.3
6 152.4	2.6 1.2	14.2 6.4				5.0 2.3	4.6 2.1	5.5 2.5	4.9 2.2	6.0 2.7	5.3 2.4	7.0 3.2	5.9 2.7
8 203.2	3.5 1.6	18.8 8.5				7.4 3.4	6.4 2.9	8.2 3.7	6.9 3.1	9.2 4.2	7.7 3.5	10.7 4.9	8.9 4.0
10 254.0	4.4 2.0	23.6 10.7				9.7 4.4	8.4 3.8	10.9 4.9	9.0 4.1	12.3 5.6	10.1 4.6	14.4 6.5	11.9 5.4
12 304.8	5.3 2.4	35.2 16.0				17.7 8.1	15.8 7.2	19.6 8.9	16.8 7.6	21.5 9.8	18.5 8.4	25.3 11.5	21.0 9.5
14 355.6	6.2 2.8	39.2 17.8				22.0 10.0	19.2 8.7	24.8 11.3	20.7 9.4	27.6 12.5	23.2 10.5	33.2 15.1	26.8 12.2
16 406.4	7.1 3.2	44.6 20.2				26.4 12.0	22.4 10.2	30.0 13.6	24.6 11.2	33.7 15.3	27.9 12.7	41.1 18.7	32.6 14.8
18 457.2	8.0 3.6	50.0 22.7				30.7 13.9	26.0 11.8	35.2 16.0	28.5 12.9	39.8 18.1	32.7 14.8	49.0 22.2	38.4 17.4
20 457.2	8.9 4.0	55.4 25.2				35.1 15.9	29.7 13.5	40.4 18.3	32.4 14.7	45.9 20.8	37.4 17.0	56.9 25.8	44.2 20.1
22 558.8	9.8 4.4	61.0 27.7				39.4 17.9	33.6 15.3	45.6 20.7	36.3 16.5	52.0 23.6	42.1 19.1	64.8 29.4	50.0 22.7
24 609.6	10.6 4.8	65.7 29.8				44.7 20.3	37.8 17.2	52.0 23.6	42.7 19.4	59.4 27.0	47.6 21.6	74.5 33.8	57.6 26.2
26 660.4	11 5.0	81 36.8				60 27.2	51 23.2	69 31.3	57 25.9	77 35.0	63 28.6	95 43.1	75 34.1
28 711.2	16 7.3	100 45.4				75 34.1	62 28.1	89 40.4	69 31.3	102 46.3	81 36.8	130 59.0	99 44.9
30 762.0	17 7.7	107 48.6				84 38.1	69 31.3	100 45.4	77 35.0	115 52.2	91 41.3	147 66.7	111 50.4
32 812.8	18 8.2	113 51.3				93 42.2	76 34.5	111 50.4	85 38.6	128 58.1	101 45.9	164 74.5	123 55.8
34 863.6	19 8.6	120 54.5				102 46.3	83 37.7	122 55.4	93 42.2	141 64.0	111 50.4	181 82.2	135 61.3
36 914.4	20 9.1	126 57.2				111 50.4	90 40.9	133 60.4	101 45.9	154 69.9	121 54.9	198 89.9	147 66.7
38 965.2	21 9.5	133 60.4				120 54.5	97 44.0	144 65.4	109 49.5	167 75.8	131 59.5	215 97.6	159 72.2
40 1016.0	22 10.0	139 63.1				125 56.8	101 45.9	152 69.0	119 54.0	179 81.3	137 62.2	234 106.2	174 79.0
42 1066.8	23 10.4	146 66.3				135 61.3	109 49.5	165 74.9	128 58.1	195 88.5	148 67.2	256 116.2	189 85.8
44 1117.6	24 10.9	153 69.5				146 66.3	116 52.7	178 80.8	138 62.7	211 95.8	161 73.1	278 126.2	205 93.1
46 1168.4	34 15.4	196 89.0				178 70.8	138 62.7	221 100.3	161 73.1	267 121.2	198 89.9	357 162.1	259 117.6
48 1219.2	36 16.3	207 94.0				406 184.3	191 86.7	147 66.7	237 107.6	287 130.3	212 96.2	384 174.3	278 126.2
50 1270.0	38 17.3	235 106.7				442 200.7	219 99.4	175 79.5	272 123.5	203 92.2	325 147.6	245 111.2	434 197.0
52 1320.8	40 18.2	246 111.7				462 209.7	234 106.2	186 84.4	291 132.1	216 98.1	349 158.4	262 118.9	466 211.6
54 1371.6	42 19.1	257 116.7				481 218.4	249 113.0	197 89.4	310 140.7	229 104.0	373 169.3	279 126.7	498 226.1
56 1422.4	44 20.0	268 121.7				500 227.0	264 119.9	208 94.4	329 149.4	242 109.9	397 180.2	296 134.4	530 240.6
58 1473.2	46 20.9	279 126.7				519 235.6	279 126.7	220 99.9	350 158.9	267 121.2	421 191.1	315 143.0	567 257.4
60 1524.0	48 21.8	351 159.4				555 255.0	599 271.9	356 161.6	292 132.6	431 195.7	342 155.3	508 230.6	393 178.4
62 1574.8	50 22.7	364 165.3				776 352.3	374 169.8	306 138.9	454 206.1	360 163.4	536 243.3	414 188.0	703 319.2
64 1625.6	52 23.6	377 171.2				806 365.9	392 178.0	320 145.3	478 217.0	377 171.2	565 256.5	435 197.5	743 337.3
66 1676.4	54 24.5	390 177.1				835 379.1	412 187.0	334 151.6	503 228.4	395 179.3	596 270.6	457 207.5	785 356.4
68 1727.2	60 27.2	420 190.7				864 392.3	492 223.4	391 177.5	614 278.8	458 207.9	627 284.7	553 251.1	997 452.6
70 1778.0	62 28.1	434 197.0				894 405.9	516 234.3	409 185.7	645 292.8	480 217.9	658 298.7	580 263.3	1051 477.2
72 1828.8	64 29.1	446 202.5				922 418.6	540 245.2	427 193.9	676 306.9	502 227.9	820 372.3	607 275.6	1105 501.7
74 1879.6	66 30.0	459 208.4				951 431.8	564 256.1	445 202.0	707 321.0	524 237.9	859 390.0	634 287.8	1159 526.2
76 1930.4	68 30.9	472 214.3				980 444.9	588 267.0	463 210.2	738 335.1	546 247.9	898 407.7	661 300.1	1213 550.7
78 1981.2	70 31.8	484 219.7				1008 457.6	612 277.8	481 218.4	769 349.1	568 257.9	937 425.4	688 312.4	1267 575.2
80 2032.0	72 32.7	498 226.1				1038 471.3	636 288.7	499 226.5	800 363.2	590 267.9	976 443.1	715 324.6	1321 599.7
82 2082.8	74 33.6	516 234.3				1068 484.9							945 429.0
84 2133.6	76 34.5	524 237.9				1096 497.6							
86 2184.4	78 35.4	538 244.3				1126 511.2							
88 2235.2	80 36.3	550 249.7				1154 523.9							
90 2286.0	82 37.3	564 256.1				1184 537.5							
92 2336.8	84 38.1	576 261.5				1212 550.2							
94 2387.6	86 39.0	590 267.9				1242 563.9							
96 2438.4	88 40.0	694 315.1				1362 618.3							
98 2489.2	121 54.9	832 377.7				1392 632.0							
100 2540.0	124 56.3	852 386.8				1424 646.5							
102 2590.8	127 57.7	870 395.0				1454 660.1							
104 2641.6	130 59.0	890 404.1				1486 674.6							
106 2692.4	133 60.4	908 412.2				1516 688.3							
108 2743.2	136 61.7	928 421.3				1548 702.8							
110 2794.0	139 63.1	946 429.5				1780 808.1							
112 2844.8	142 64.5	966 438.6				1820 826.3							
114 2895.6	145 65.8	984 446.7				1858 843.5							
116 2946.4	148 67.2	1004 455.8				1898 861.7							
118 2997.2	151 68.6	1022 464.0				1936 878.9							
120 3048.0	154 69.9	1042 473.1				1976 897.1							

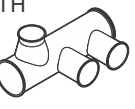
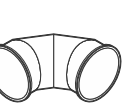
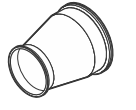
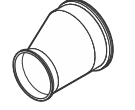
METRIC EQUIVALENTS ARE SHOWN IN PARENTHESIS & ITALICS (MILLIMETERS OR AS NOTED)

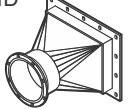
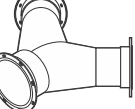
<p>ROUND DUCT</p>	<p>STRAIGHT DUCT</p>  <p>SIZE: 4"<i>(101.6)</i> - 120"<i>(3048.0)</i></p> <p>• PAGE: 18</p>	<p>STRAIGHT DUCT WITH FAB-TECH FLANGE</p>  <p>SIZE: 2"<i>(50.8)</i> & 3" <i>(76.2)</i></p> <p>• PAGE: 19</p>	
<p>STRAIGHT DUCT WITH STRAIGHT TAP</p>  <p>SIZE: 6"<i>(152.4)</i> - 120"<i>(3048.0)</i></p> <p>• PAGE: 20</p>	<p>STRAIGHT DUCT WITH CONICAL TAP</p>  <p>SIZE: 6"<i>(152.4)</i> - 120"<i>(3048.0)</i></p> <p>• PAGE: 21</p>	<p>STRAIGHT DUCT WITH SHOE TAP</p>  <p>SIZE: 6"<i>(152.4)</i> - 120"<i>(3048.0)</i></p> <p>• PAGE: 22</p>	
<p>STRAIGHT DUCT WITH LATERAL TAP</p>  <p>SIZE: 6"<i>(152.4)</i> - 120"<i>(3048.0)</i></p> <p>• PAGE: 23</p>	<p>STRAIGHT DUCT WITH MULTIPLE TAPS</p>  <p>SIZE: 4"<i>(101.6)</i> - 120"<i>(3048.0)</i></p> <p>• PAGE: 24</p>	<p>GORED ELBOW 30°, 45°, 60°, 90°</p>  <p>SIZE: 4"<i>(101.6)</i> - 120"<i>(3048.0)</i></p> <p>• PAGE: 25</p>	
<p>CONCENTRIC REDUCER</p>  <p>SIZE: 6"<i>(152.4)</i> - 120"<i>(3048.0)</i></p> <p>• PAGE: 26</p>	<p>ECCENTRIC REDUCER</p>  <p>SIZE: 6"<i>(152.4)</i> - 120"<i>(3048.0)</i></p> <p>• PAGE: 26</p>	<p>OFFSET</p>  <p>SIZE: 4"<i>(101.6)</i> - 120"<i>(3048.0)</i></p> <p>• PAGE: 27</p>	
<p>END CAP</p>  <p>SIZE: 4"<i>(101.6)</i> - 120"<i>(3048.0)</i></p> <p>• PAGE: 28</p>	<p>MESH END CAP</p>  <p>SIZE: 4"<i>(101.6)</i> - 36"<i>(914.4)</i></p> <p>• PAGE: 29</p>	<p>CONCENTRIC ROUND TO RECTANGULAR TRANSITION</p>  <p>• PAGE: 30</p>	<p>CUSTOM FITTING</p>  <p>• PAGE: 31</p>
<p>ROUND DUCT EZ CLAMP</p>	<p>STRAIGHT DUCT</p>  <p>SIZE: 4"<i>(101.6)</i> - 14"<i>(355.6)</i></p> <p>• PAGE: 18</p>	<p>STRAIGHT DUCT WITH FAB-TECH FLANGE</p>  <p>SIZE: 2"<i>(50.8)</i> & 3" <i>(76.2)</i></p> <p>• PAGE: 19</p>	
<p>STRAIGHT DUCT WITH STRAIGHT TAP</p>  <p>SIZE: 4"<i>(101.6)</i> - 14"<i>(355.6)</i></p> <p>• PAGE: 20</p>	<p>STRAIGHT DUCT WITH CONICAL TAP</p>  <p>SIZE: 6"<i>(152.4)</i> - 14"<i>(355.6)</i></p> <p>• PAGE: 21</p>	<p>STRAIGHT DUCT WITH SHOE TAP</p>  <p>SIZE: 6"<i>(152.4)</i> - 14"<i>(355.6)</i></p> <p>• PAGE: 22</p>	
<p>STRAIGHT DUCT WITH LATERAL TAP</p>  <p>SIZE: 4"<i>(101.6)</i> - 14"<i>(355.6)</i></p> <p>• PAGE: 23</p>	<p>STRAIGHT DUCT WITH MULTIPLE TAPS</p>  <p>SIZE: 4"<i>(101.6)</i> - 14"<i>(355.6)</i></p> <p>• PAGE: 24</p>	<p>GORED ELBOWS 30°, 45°, 60°, 90°</p>  <p>SIZE: 4"<i>(101.6)</i> - 14"<i>(355.6)</i></p> <p>• PAGE: 25</p>	
<p>CONCENTRIC REDUCER</p>  <p>SIZE: 4"<i>(101.6)</i> - 14"<i>(355.6)</i></p> <p>• PAGE: 26</p>	<p>ECCENTRIC REDUCER</p>  <p>SIZE: 4"<i>(101.6)</i> - 14"<i>(355.6)</i></p> <p>• PAGE: 26</p>	<p>OFFSET</p>  <p>SIZE: 4"<i>(101.6)</i> - 14"<i>(355.6)</i></p> <p>• PAGE: 27</p>	
<p>END CAP</p>  <p>SIZE: 4"<i>(101.6)</i> - 14"<i>(355.6)</i></p> <p>• PAGE: 28</p>	<p>CONCENTRIC ROUND TO RECTANGULAR TRANSITION</p>  <p>• PAGE: 30</p>	<p>CUSTOM FITTING</p>  <p>• PAGE: 31</p>	

METRIC EQUIVALENTS ARE SHOWN IN PARENTHESIS & ITALICS (MILLIMETERS OR AS NOTED)

Straight Duct

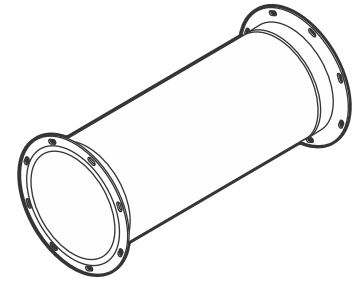
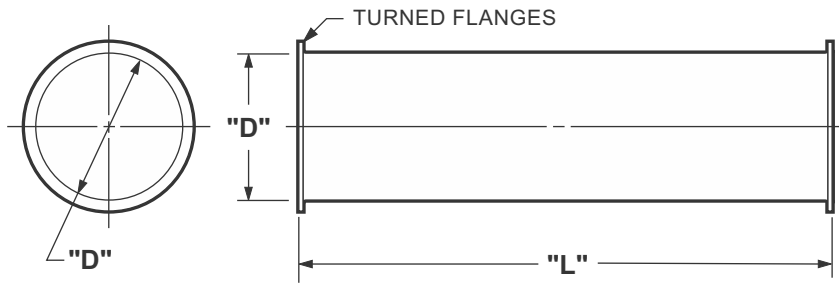

STANDARD DUCT LENGTHS ("L1")

RING	DIAMETER	"L1"=4' (1219.2)	"L1"=8' (2438.4)
EZ/SC	4" (101.6) & 6" (152.4)	47.25" (1200.5)	NA
EZ/SC	8" (203.2) TO 14" (355.6)	47.25" (1200.5)	95.25" (2419.35)
BI	4" (101.6) & 6" (152.4)	47.25" (1200.5)	NA
BI	8" (203.2) TO 48" (1219.2)	47.25" (1200.5)	95.25" (2419.35)
BI	50" (1270) TO 120" (3048)	46.75" (1187.45)	94.75" (2406.65)
SS	16" (406.4) TO 48" (1219.2)	47.25" (1200.5)	95.25" (2419.35)
SS	50" (1270) TO 120" (3048)	46.75" (1187.45)	94.75" (2406.65)

DUCT JOINT / RING TYPE

- EZ** EZ CLAMP
4"Ø-14"Ø (101.6 - 355.6)
- SC** STAINLESS CAST RING
4"Ø-14"Ø (101.6 - 355.6)
- BI** BLACK IRON ANGLE RING
4"Ø-120"Ø (101.6 - 3048.0)
- SS** STAINLESS ANGLE RING
16"Ø-120"Ø (406.4 - 3048.0)

STANDARD PTFE GASKETS

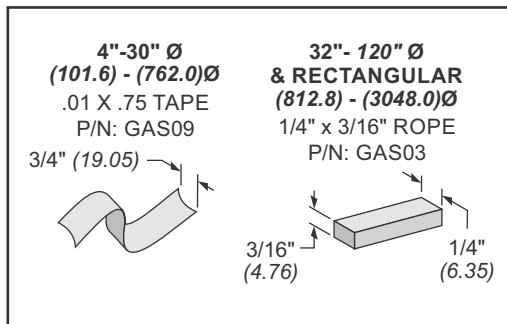

* ADHESIVE ON ONE SIDE

GASKET APPLICATION EXCEPTIONS TABLE

Product	Size Inches (mm)	Gasket Application			
		GAS01	GAS02	GAS03	GAS09
Wafer Damper	4(101.6) - 10(254.0)	F*			F**
	12(304.8) - 14(355.6)		F*		F**
End Cap	4(101.6) - 10(254.0)	F*			F**
	12(304.8) - 14(355.6)		F*		F**
	16(406.4) - 24(609.6)		F		
	26(660.4) - 30(762.0)			F	
AMCA HVD Damper HVD Damper Ultra Series Damper Blastgate - Actuated	16(406.4) - 24(609.6)		P		
	26+(660.4)			P	

P - Apply gasket on PRODUCT
F - Apply gasket on adjoining FLANGE

* - Apply specified gasket on top of GAS09
** - Factory applied gasket

NOTE: GASKET APPLICATION EXCEPTIONS

WHERE STANDARD GASKET APPLICATION IS NOT POSSIBLE; FOR EXAMPLE WHEN JOINING AN END CAP TO A STANDARD DUCT FLANGE IN SIZES BELOW 32" (812.8) DIAMETER THERE IS NO ROLLED FLANGE FACE TO APPLY GAS09 GASKET TAPE ON THE CAP. IN THIS INSTANCE, USE THE EXCEPTIONS TABLE TO IDENTIFY THE PROPER GASKET APPLICATION REQUIREMENTS. FOR THIS EXAMPLE; WITH A 14" (355.6) END CAP, APPLY GAS02 GASKET OVER THE DUCT FLANGE GAS09 PRIOR TO ASSEMBLY OF THE JOINT.

NOTES:

- SEE THE **STANDARDS SECTION** FOR INFORMATION ABOUT DUCT GAUGE, DUCT PRESSURE CLASSES, RING MECHANICAL SPECS, HARDWARE AND GASKETS.
- 1 OPTION:** CUSTOM LENGTH
- 2 OPTION:** RAW END
- 3 OPTION:** REFER TO FAB-TECH FLANGE SYSTEM SECTION FOR ADAPTERS, DRAINS AND TEST PORTS. RAW END
- DUCT GREATER THAN 84" DIA. (2133.6mm) REQUIRES FAB-TECH ENGINEERING REVIEW AND APPROVAL.
- GREATER THAN STANDARD DUCT LENGTHS AND/OR HIGHER SYSTEM PRESSURES MAY REQUIRE ADDITIONAL STIFFENERS PER SMACNA, CONTACT FAB-TECH FOR SPECIFIC GUIDELINES.
- SEE INSTALLATION AND ASSEMBLY GUIDE FOR SHORTENING 4" THRU 22" DUCT IN THE FIELD.
- ALL DUCT FITTINGS WITH STANDARD FAB-TECH CONNECTIONS INCLUDE GASKETS AND CLAMPS OR HARDWARE AS REQUIRED FOR INSTALLATION.

METRIC EQUIVALENTS ARE SHOWN IN PARENTHESIS & ITALICS (MILLIMETERS OR AS NOTED)

Straight Duct with Fab-Tech Flange

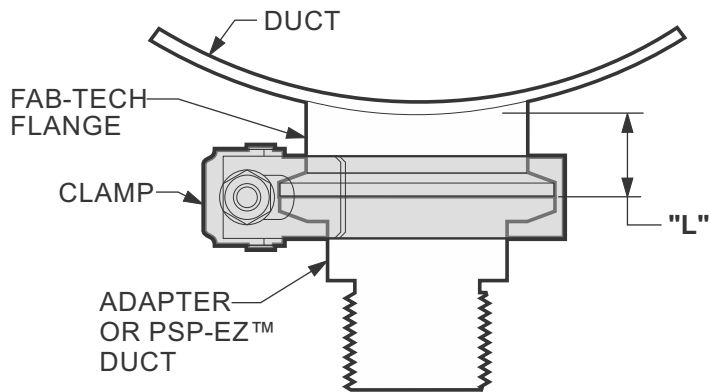
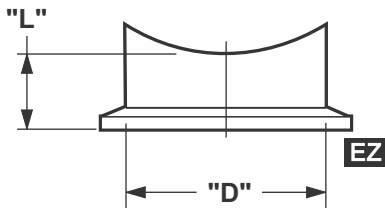
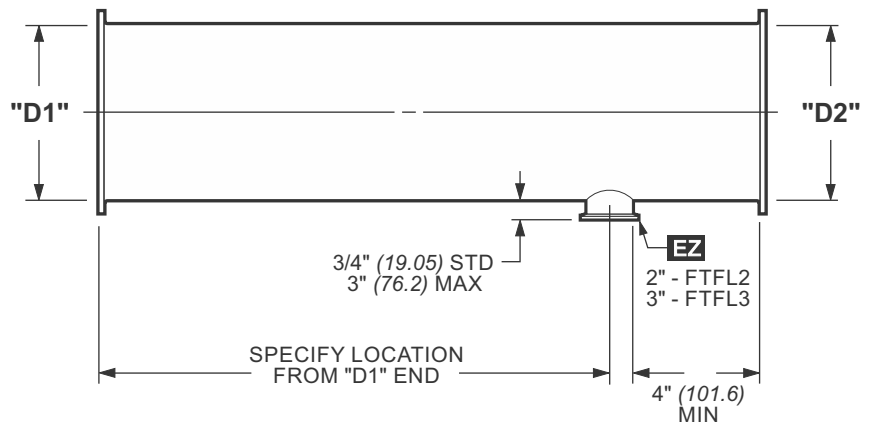
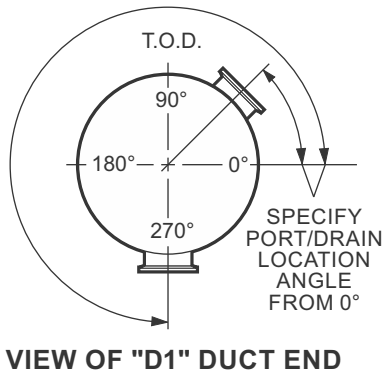
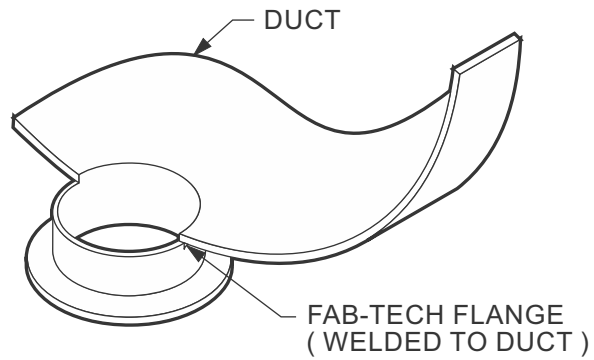

PART NO.	DESCRIPTION	"D"	"L"
FTFL2	2" FT FLANGE	2" (50.8)	.75" (19.05)
FTFL3	3" FT FLANGE	3" (76.2)	.75" (19.05)

NOTES:

1. OUR RECOMMENDATION IS TO ADD TAPS TO STANDARD 4' (1219.2) AND 8' (2438.4) STRAIGHT DUCT WHEN POSSIBLE - TAP DIMENSIONS SHOWN ARE MINS.
2. SEE FAB-TECH FLANGE SYSTEM SECTION FOR ADAPTERS AND THE EZ FITTINGS SECTION FOR DUCT TO USE WITH THE FAB-TECH FLANGE. THE FAB-TECH FLANGE / TEST PORT MAY BE INSTALLED ON FITTINGS OTHER THAN STRAIGHT DUCT (USE CUSTOM ORDER SHEET).

METRIC EQUIVALENTS ARE SHOWN IN PARENTHESIS & ITALICS (MILLIMETERS OR AS NOTED)

Straight Duct with Straight Tap

STRAIGHT TAP

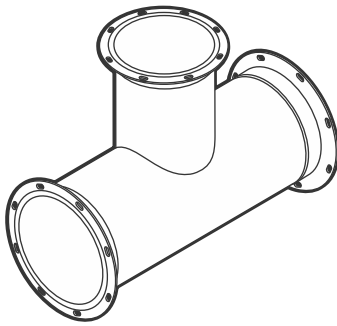

"L1" MIN = "D3" + 8" (203.2)
 "L1" MAX = 96-1/4" (2444.8)
 "D3" MAX = 88" (2235.2)

STRAIGHT TAP GREATER THAN 88" (2235.2) ["D3"] REQUIRES 2 PIECE DESIGN AND ENGINEERING REVIEW

*** MIN DISTANCE TO DUCT END**
 "D1" = 4" (101.6) - 94" (2387.6) : 4" (101.6) MIN
 "D1" = 96" (2438.4) - 120" (3048.0) : 5" (127.0) MIN

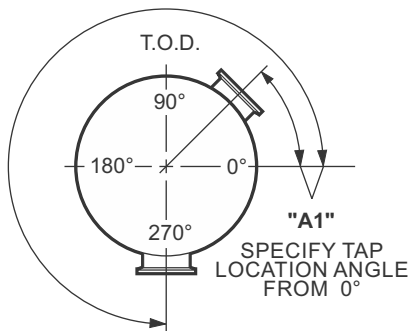

VIEW OF "D1" DUCT END

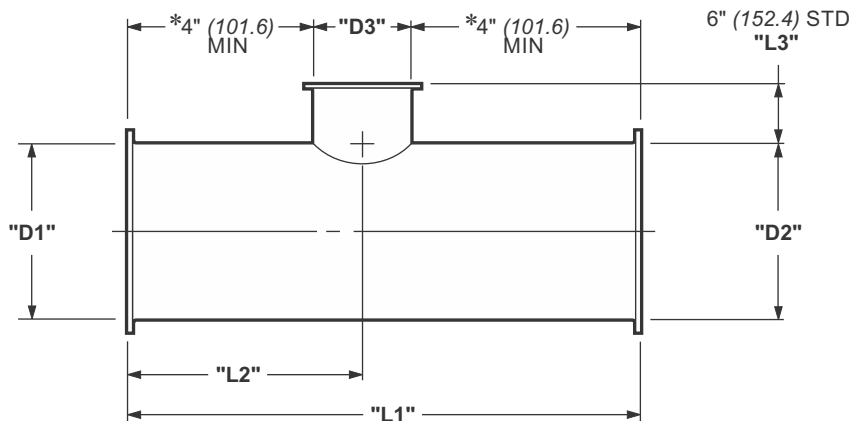

STANDARD DUCT LENGTHS ("L1")

RING	DIAMETER	"L1"=4' (1219.2)	"L1"=8' (2438.4)
EZ/SC	4" (101.6) & 6" (152.4)	47.25" (1200.5)	NA
EZ/SC	8" (203.2) TO 14" (355.6)	47.25" (1200.5)	95.25" (2419.35)
BI	4" (101.6) & 6" (152.4)	47.25" (1200.5)	NA
BI	8" (203.2) TO 48" (1219.2)	47.25" (1200.5)	95.25" (2419.35)
BI	50" (1270) TO 120" (3048)	46.75" (1187.45)	94.75" (2406.65)
SS	16" (406.4) TO 48" (1219.2)	47.25" (1200.5)	95.25" (2419.35)
SS	50" (1270) TO 120" (3048)	46.75" (1187.45)	94.75" (2406.65)

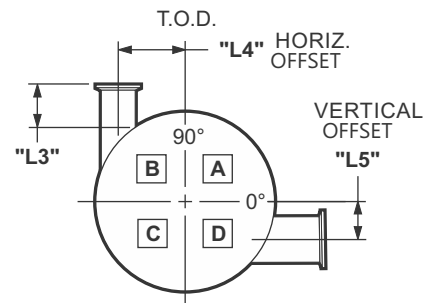

"D1" TAP OFFSET VIEW

NOTES:

- OUR RECOMMENDATION IS TO ADD TAPS TO STANDARD 4' (1219.2) AND 8' (2438.4) STRAIGHT DUCT WHEN POSSIBLE - TAP DIMENSIONS SHOWN ARE MINIMUMS.
- SEE THE STANDARDS SECTION FOR INFORMATION ABOUT DUCT GAUGE, DUCT PRESSURE CLASSES, RING MECHANICAL SPECS, HARDWARE AND GASKETS.
- 1 OPTION:** CUSTOM LENGTH
- 2 OPTION:** RAW END
- 3 OPTION:** MULTIPLE & OFFSET TAPS AVAILABLE (SEE THE MULTIPLE TAP PAGE).
- DUCT GREATER THAN 84" DIA. (2133.6) REQUIRES FAB-TECH ENGINEERING REVIEW AND APPROVAL.
- GREATER THAN STANDARD DUCT LENGTHS AND/OR HIGHER SYSTEM PRESSURES MAY REQUIRE ADDITIONAL STIFFENERS PER SMACNA, CONTACT FAB-TECH FOR SPECIFIC GUIDELINES.
- ALL DUCT FITTINGS WITH STANDARD FAB-TECH CONNECTIONS INCLUDE GASKETS AND CLAMPS OR HARDWARE AS REQUIRED FOR INSTALLATION.

DUCT JOINT / RING TYPE

- EZ** EZ CLAMP
4"Ø-14"Ø (101.6 - 355.6)
- SC** STAINLESS CAST RING
4"Ø-14"Ø (101.6 - 355.6)
- BI** BLACK IRON ANGLE RING
4"Ø-120"Ø (101.6 - 3048.0)
- SS** STAINLESS ANGLE RING
16"Ø-120"Ø (406.4 - 3048.0)

METRIC EQUIVALENTS ARE SHOWN IN PARENTHESIS & ITALICS (MILLIMETERS OR AS NOTED)

Straight Duct with Conical Tap

CONICAL TAP

"L1" MIN = "D3" + 10" (254.0)
 "L1" MAX = 96-1/4" (2444.8)
 "D3" MAX = 86" (2184.4)

CONICAL TAP GREATER THAN 86" (2184.4) ["D3"] REQUIRES 2 PIECE DESIGN AND ENGINEERING REVIEW

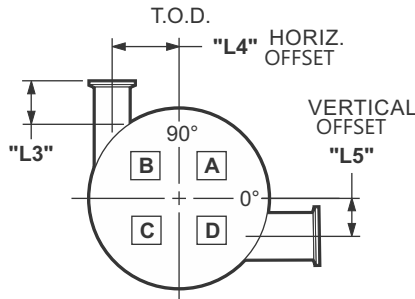
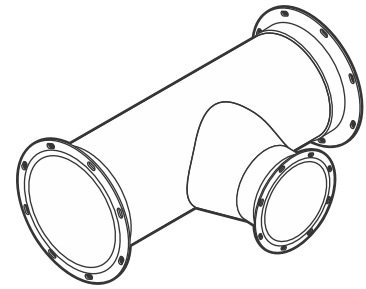

"D1" TAP OFFSET VIEW

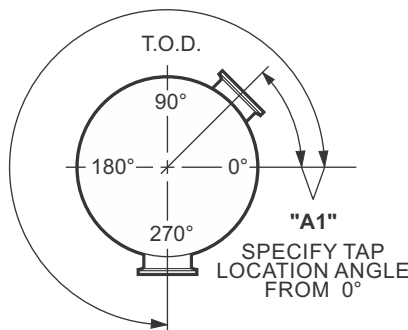

VIEW OF "D1" DUCT END

*** MIN DISTANCE TO DUCT END**
 "D1" = 4" (101.6) - 94" (2387.6) : 4" (101.6) MIN
 "D1" = 96" (2438.4) - 120" (3048.0) : 5" (127.0) MIN

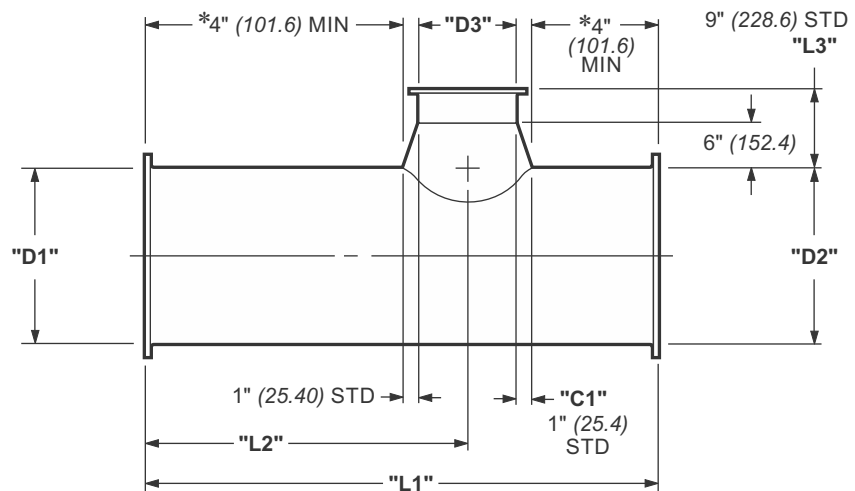

STANDARD DUCT LENGTHS ("L1")

RING	DIAMETER	"L1"=4' (1219.2)	"L1"=8' (2438.4)
EZ/SC	4" (101.6) & 6" (152.4)	47.25" (1200.5)	NA
EZ/SC	8" (203.2) TO 14" (355.6)	47.25" (1200.5)	95.25" (2419.35)
BI	4" (101.6) & 6" (152.4)	47.25" (1200.5)	NA
BI	8" (203.2) TO 48" (1219.2)	47.25" (1200.5)	95.25" (2419.35)
BI	50" (1270) TO 120" (3048)	46.75" (1187.45)	94.75" (2406.65)
SS	16" (406.4) TO 48" (1219.2)	47.25" (1200.5)	95.25" (2419.35)
SS	50" (1270) TO 120" (3048)	46.75" (1187.45)	94.75" (2406.65)

NOTES:

- OUR RECOMMENDATION IS TO ADD TAPS TO STANDARD 4' (1219.2) AND 8' (2438.4) STRAIGHT DUCT WHEN POSSIBLE - TAP DIMENSIONS SHOWN ARE MINIMUMS.2
- SEE THE STANDARDS SECTION FOR INFORMATION ABOUT DUCT GAUGE, DUCT PRESSURE CLASSES, RING MECHANICAL SPECS, HARDWARE AND GASKETS.
- 1 OPTION:** CUSTOM LENGTH
- 2 OPTION:** RAW END
- 3 OPTION:** MULTIPLE & OFFSET TAPS AVAILABLE (SEE THE MULTIPLE TAP PAGE).
- DUCT GREATER THAN 84" DIA. (2133.6mm) REQUIRES FAB-TECH ENGINEERING REVIEW AND APPROVAL.
- GREATER THAN STANDARD DUCT LENGTHS AND/OR HIGHER SYSTEM PRESSURES MAY REQUIRE ADDITIONAL STIFFENERS PER SMACNA, CONTACT FAB-TECH FOR SPECIFIC GUIDELINES.
- ALL DUCT FITTINGS WITH STANDARD FAB-TECH CONNECTIONS INCLUDE GASKETS AND CLAMPS OR HARDWARE AS REQUIRED FOR INSTALLATION.

DUCT JOINT / RING TYPE

- EZ** EZ CLAMP
4"Ø-14"Ø (101.6 - 355.6)
- SC** STAINLESS CAST RING
4"Ø-14"Ø (101.6 - 355.6)
- BI** BLACK IRON ANGLE RING
4"Ø-120"Ø (101.6 - 3048.0)
- SS** STAINLESS ANGLE RING
16"Ø-120"Ø (406.4 - 3048.0)

METRIC EQUIVALENTS ARE SHOWN IN PARENTHESIS & ITALICS (MILLIMETERS OR AS NOTED)

Straight Duct with Shoe Tap

SHOE TAP

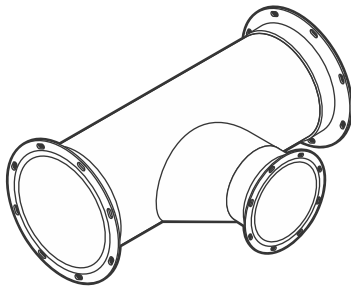

"L1" MIN = "D3" + 6" (152.4)(SHOE LENGTH) + 8" (203.2)

"L1" MAX = 96-1/4" (2444.8)

"D3" MAX = 86" (2184.4)

SHOE TAP GREATER THAN MAX "D3"
REQUIRES 2 PIECE DESIGN
AND ENGINEERING REVIEW

*** MIN DISTANCE TO DUCT END**
"D1" = 4" (101.6) - 94" (2387.6) : 4" (101.6) MIN
"D1" = 96" (2438.4) - 120" (3048.0) : 5" (127.0) MIN

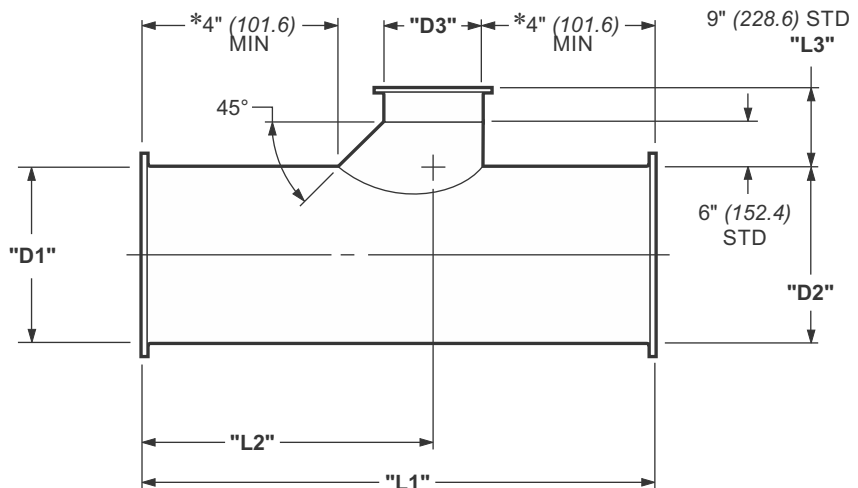
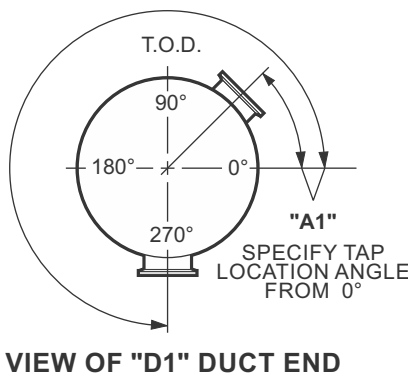

STANDARD DUCT LENGTHS ("L1")

RING	DIAMETER	"L1"=4' (1219.2)	"L1"=8' (2438.4)
EZ/SC	4" (101.6) & 6" (152.4)	47.25" (1200.5)	NA
EZ/SC	8" (203.2) TO 14" (355.6)	47.25" (1200.5)	95.25" (2419.35)
BI	4" (101.6) & 6" (152.4)	47.25" (1200.5)	NA
BI	8" (203.2) TO 48" (1219.2)	47.25" (1200.5)	95.25" (2419.35)
BI	50" (1270) TO 120" (3048)	46.75" (1187.45)	94.75" (2406.65)
SS	16" (406.4) TO 48" (1219.2)	47.25" (1200.5)	95.25" (2419.35)
SS	50" (1270) TO 120" (3048)	46.75" (1187.45)	94.75" (2406.65)

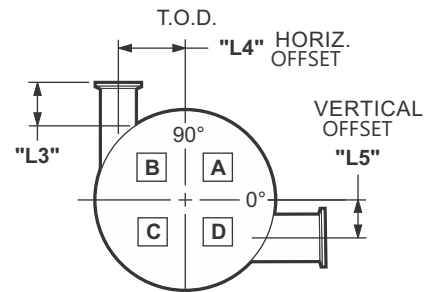

NOTES:

- OUR RECOMMENDATION IS TO ADD TAPS TO STANDARD 4' (1219.2) AND 8' (2438.4) STRAIGHT DUCT WHEN POSSIBLE - TAP DIMENSIONS SHOWN ARE MINIMUMS.
- SEE THE STANDARDS SECTION FOR INFORMATION ABOUT DUCT GAUGE, DUCT PRESSURE CLASSES, RING MECHANICAL SPECS, HARDWARE AND GASKETS.
- 1 OPTION:** CUSTOM LENGTH
- 2 OPTION:** RAW END
- 3 OPTION:** MULTIPLE & OFFSET TAPS AVAILABLE (SEE THE MULTIPLE TAP PAGE).
- DUCT GREATER THAN 84" DIA. (2133.6mm) REQUIRES FAB-TECH ENGINEERING REVIEW AND APPROVAL.
- GREATER THAN STANDARD DUCT LENGTHS AND/OR HIGHER SYSTEM PRESSURES MAY REQUIRE ADDITIONAL STIFFENERS PER SMACNA, CONTACT FAB-TECH FOR SPECIFIC GUIDELINES.
- ALL DUCT FITTINGS WITH STANDARD FAB-TECH CONNECTIONS INCLUDE GASKETS AND CLAMPS OR HARDWARE AS REQUIRED FOR INSTALLATION.

DUCT JOINT / RING TYPE

- EZ** EZ CLAMP
4"Ø-14"Ø (101.6 - 355.6)
- SC** STAINLESS CAST RING
4"Ø-14"Ø (101.6 - 355.6)
- BI** BLACK IRON ANGLE RING
4"Ø-120"Ø (101.6 - 3048.0)
- SS** STAINLESS ANGLE RING
16"Ø-120"Ø (406.4 - 3048.0)

METRIC EQUIVALENTS ARE SHOWN IN PARENTHESIS & ITALICS (MILLIMETERS OR AS NOTED)

Straight Duct with Lateral Tap

45° LATERAL TAP

"L1" MIN = ("D3" X 1.414) + "L2 MIN" + "L4"
 (SEE MIN LENGTH CHART FOR "L4")
 "L1" MAX = 96-1/4" (2444.8)
 "D3" MAX = 60" (152.4)

LATERAL TAP GREATER THAN 60" (152.4) ["D3"] REQUIRES 2 PIECE DESIGN AND ENGINEERING REVIEW

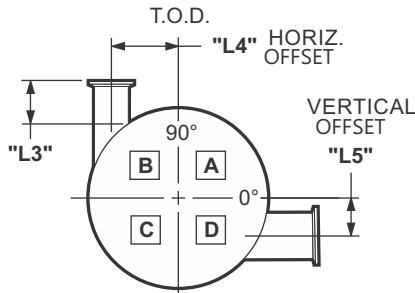
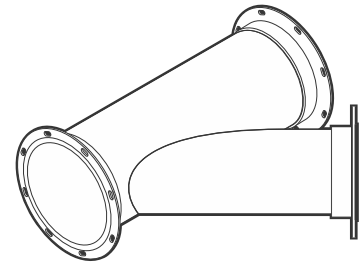

"D1" TAP OFFSET VIEW

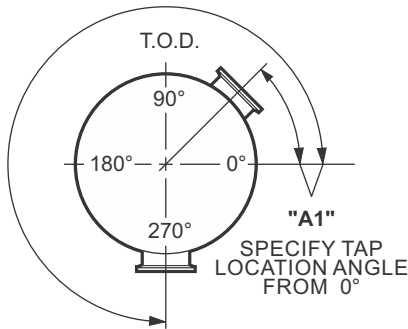

VIEW OF "D1" DUCT END

*** L2 MIN DISTANCE TO DUCT END**
 "D1" = 4" (101.6) - 94" (2387.6) : 4" (101.6) MIN
 "D1" = 96" (2438.4) - 120" (3048.0) : 5" (127.0) MIN

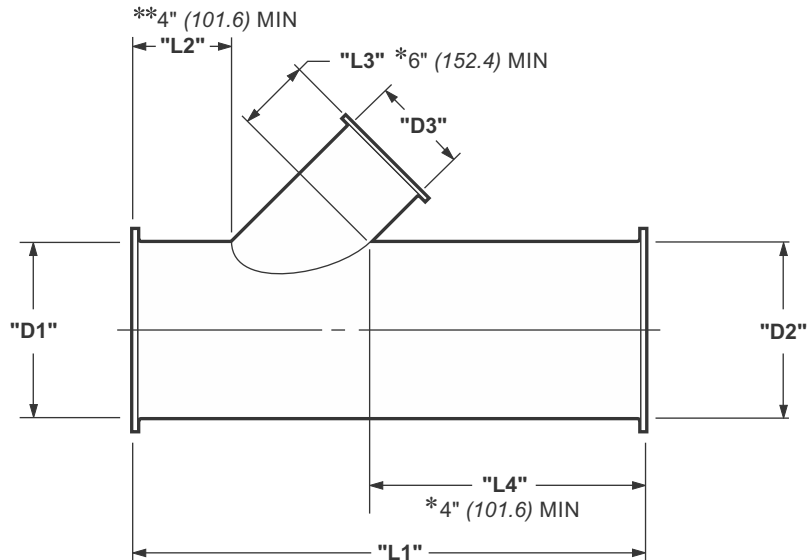

STANDARD DUCT LENGTHS ("L1")

RING	DIAMETER	"L1"=4' (1219.2)	"L1"=8' (2438.4)
EZ/SC	4" (101.6) & 6" (152.4)	47.25" (1200.5)	NA
EZ/SC	8" (203.2) TO 14" (355.6)	47.25" (1200.5)	95.25" (2419.35)
BI	4" (101.6) & 6" (152.4)	47.25" (1200.5)	NA
BI	8" (203.2) TO 48" (1219.2)	47.25" (1200.5)	95.25" (2419.35)
BI	50" (1270) TO 120" (3048)	46.75" (1187.45)	94.75" (2406.65)
SS	16" (406.4) TO 48" (1219.2)	47.25" (1200.5)	95.25" (2419.35)
SS	50" (1270) TO 120" (3048)	46.75" (1187.45)	94.75" (2406.65)

*MINIMUM LENGTH FOR "L3" AND "L4"		
"D1"	"L3"	"L4"
4" (101.6) - 48" (1219.2)	6" (152.4)	4" (101.6)
50" (1270.0) - 58" (1473.2)	7" (177.8)	4" (101.6)
60" (1524.0) - 94" (2387.6)	8" (203.2)	5" (127.0)
96" (2438.4) - 120" (3048.0)	10 1/2" (266.7)	6" (152.4)

NOTES:

- OUR RECOMMENDATION IS TO ADD TAPS TO STANDARD 4' (1219.2) AND 8' (2438.4) STRAIGHT DUCT WHEN POSSIBLE - TAP DIMENSIONS SHOWN ARE MINIMUMS.
- SEE THE STANDARDS SECTION FOR INFORMATION ABOUT DUCT GAUGE, DUCT PRESSURE CLASSES, RING MECHANICAL SPECS, HARDWARE AND GASKETS.
- 1 OPTION:** CUSTOM LENGTH
- 2 OPTION:** RAW END
- 3 OPTION:** MULTIPLE & OFFSET TAPS AVAILABLE (SEE THE MULTIPLE TAP PAGE).
- DUCT GREATER THAN 84" DIA. (2133.6mm) REQUIRES FAB-TECH ENGINEERING REVIEW AND APPROVAL.
- GREATER THAN STANDARD DUCT LENGTHS AND/OR HIGHER SYSTEM PRESSURES MAY REQUIRE ADDITIONAL STIFFENERS PER SMACNA, CONTACT FAB-TECH FOR SPECIFIC GUIDELINES.
- ALL DUCT FITTINGS WITH STANDARD FAB-TECH CONNECTIONS INCLUDE GASKETS AND CLAMPS OR HARDWARE AS REQUIRED FOR INSTALLATION.

DUCT JOINT / RING TYPE

- EZ** EZ CLAMP
4"Ø-14"Ø (101.6 - 355.6)
- SC** STAINLESS CAST RING
4"Ø-14"Ø (101.6 - 355.6)
- BI** BLACK IRON ANGLE RING
4"Ø-120"Ø (101.6 - 3048.0)
- SS** STAINLESS ANGLE RING
16"Ø-120"Ø (406.4 - 3048.0)

METRIC EQUIVALENTS ARE SHOWN IN PARENTHESIS & ITALICS (MILLIMETERS OR AS NOTED)

*** MIN DISTANCE TO DUCT END**
 "D1" = 4" (101.6) - 94" (2387.6) : 4" (101.6) MIN
 "D1" = 96" (2438.4) - 120" (3048.0) : 5" (127.0) MIN

Straight Duct with Multiple Tap

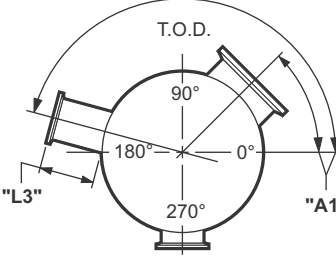
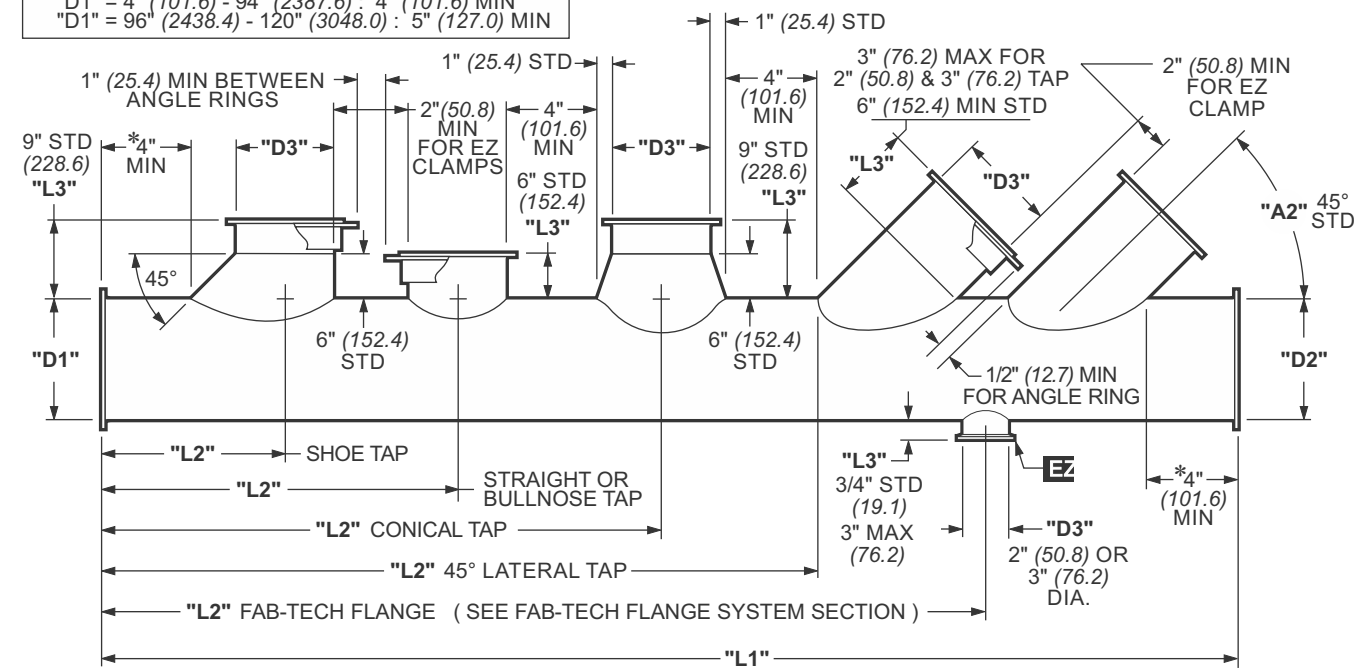

"D1" TAP ANGLE VIEW
 SPECIFY TAP ANGLE FROM 0° AT D1 END

STANDARD DUCT LENGTHS ("L1")

RING	DIAMETER	"L1"=4' (1219.2)	"L1"=8' (2438.4)
EZ/SC	4" (101.6) & 6" (152.4)	47.25" (1200.5)	NA
EZ/SC	8" (203.2) TO 14" (355.6)	47.25" (1200.5)	95.25" (2419.35)
BI	4" (101.6) & 6" (152.4)	47.25" (1200.5)	NA
BI	8" (203.2) TO 48" (1219.2)	47.25" (1200.5)	95.25" (2419.35)
BI	50" (1270) TO 120" (3048)	46.75" (1187.45)	94.75" (2406.65)
SS	16" (406.4) TO 48" (1219.2)	47.25" (1200.5)	95.25" (2419.35)
SS	50" (1270) TO 120" (3048)	46.75" (1187.45)	94.75" (2406.65)

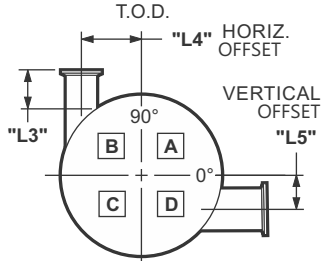

"D1" TAP OFFSET VIEW

NOTES:

1. OUR RECOMMENDATION IS TO ADD TAPS TO STANDARD 4' (1219.2) AND 8' (2438.4) STRAIGHT DUCT WHEN POSSIBLE - TAP DIMENSIONS SHOWN ARE MINIMUMS.
2. SEE THE STANDARDS SECTION FOR INFORMATION ABOUT DUCT GAUGE, DUCT PRESSURE CLASSES, RING MECHANICAL SPECS, HARDWARE AND GASKETS.
3. **1 OPTION: CUSTOM LENGTH**
4. **2 OPTION: RAW END**
5. DUCT GREATER THAN 84" DIA. (2133.6mm) REQUIRES FAB-TECH ENGINEERING REVIEW AND APPROVAL.
7. GREATER THAN STANDARD DUCT LENGTHS AND/OR HIGHER SYSTEM PRESSURES MAY REQUIRE ADDITIONAL STIFFENERS PER SMACNA, CONTACT FAB-TECH FOR SPECIFIC GUIDELINES.
8. ALL DUCT FITTINGS WITH STANDARD FAB-TECH CONNECTIONS INCLUDE GASKETS AND CLAMPS OR HARDWARE AS REQUIRED FOR INSTALLATION.

DUCT JOINT / RING TYPE

- EZ** EZ CLAMP
4"Ø-14"Ø (101.6 - 355.6)
- SC** STAINLESS CAST RING
4"Ø-14"Ø (101.6 - 355.6)
- BI** BLACK IRON ANGLE RING
4"Ø-120"Ø (101.6 - 3048.0)
- SS** STAINLESS ANGLE RING
16"Ø-120"Ø (406.4 - 3048.0)

***STANDARD MINIMUMS FOR 45° LATERAL AND 90° STRAIGHT TAPS:**

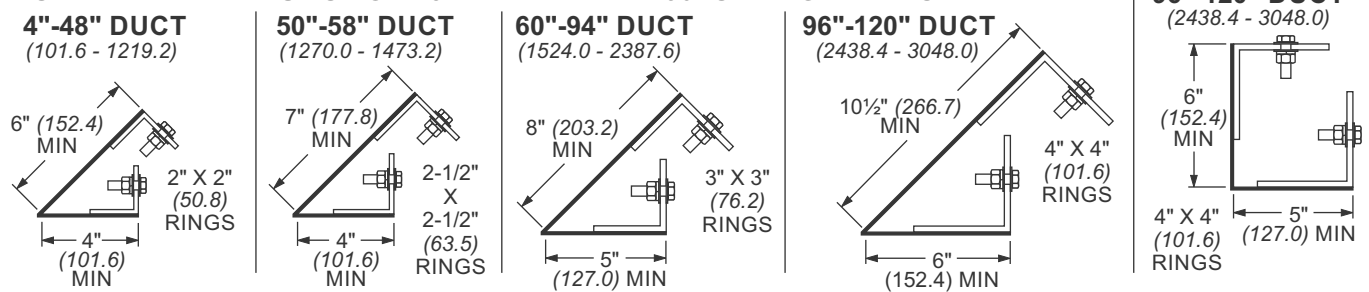

METRIC EQUIVALENTS ARE SHOWN IN PARENTHESIS & ITALICS (MILLIMETERS OR AS NOTED)

Gored Elbow

STANDARD RADIUS AT THE DUCT CENTERLINE

"R1" = 1.5 X "D"

STANDARD THROAT RADIUS

"R2" = "D"

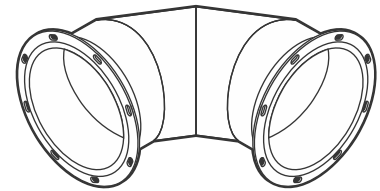

LIMITATIONS

DUE TO MANUFACTURING LIMITATIONS, THE FOLLOWING ELBOWS ARE NOT AVAILABLE AS ONE PIECE FITTINGS:

- FULL RADIUS 90° ELBOW > 56" (1422.4) DIA.
- FULL RADIUS 60° ELBOW > 82" (2082.8) DIA.
- FULL RADIUS 45° ELBOW > 106" (2092.4) DIA.
- HALF RADIUS 90° ELBOW > 76" (1930.4) DIA.

LARGE ELBOWS ABOVE THESE LIMITS WILL BE MANUFACTURED AS SMALLER FITTINGS (AN 86" DIA. 90° ELBOW WILL BE SUPPLIED AS TWO 45° ELBOWS FOR EXAMPLE) OR AS A CLAM SHELL DESIGNED FITTING AS TWO OR MORE PIECES. THIS APPLIES TO ALL LARGE FITTINGS AS WELL AS ELBOWS.

ALSO DUE TO MANUFACTURING LIMITATIONS, MANY OF THE SMALLER 1/2 RADIUS ELBOWS WILL REQUIRE CAST RINGS OR FLAT RINGS.

90° ELBOW

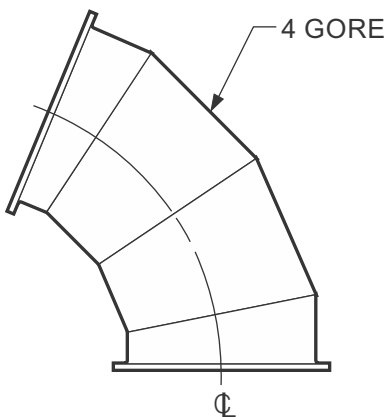
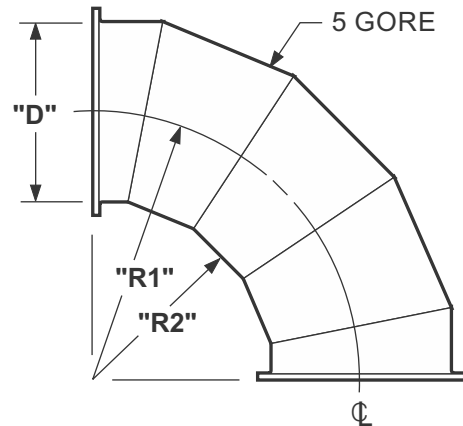

60° ELBOW

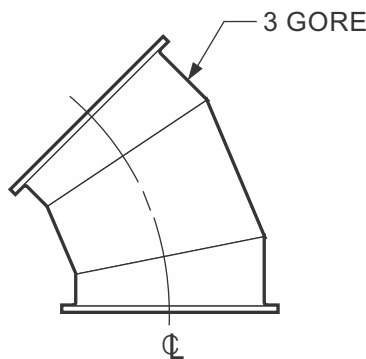

45° ELBOW

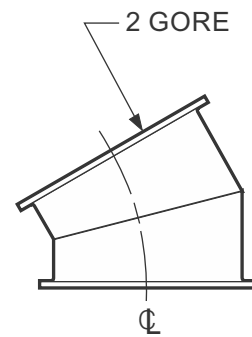

30° ELBOW

NOTES:

1. SEE THE STANDARDS SECTION FOR INFORMATION ABOUT DUCT GAUGE, DUCT PRESSURE CLASSES, RING MECHANICAL SPECS, HARDWARE AND GASKETS.
2. **1** **OPTION:** CUSTOM NUMBER OF GORES AVAILABLE
3. **2** **OPTION:** CUSTOM RADII AVAILABLE
4. **3** **OPTION:** THROAT EXTENSIONS AVAILABLE
5. DUCT GREATER THAN 84" DIA. (2133.6mm) REQUIRES FAB-TECH ENGINEERING REVIEW AND APPROVAL.
6. ALL DUCT FITTINGS WITH STANDARD FAB-TECH CONNECTIONS INCLUDE GASKETS AND CLAMPS OR HARDWARE AS REQUIRED FOR INSTALLATION.

DUCT JOINT / RING TYPE

- EZ** EZ CLAMP
4"Ø-14"Ø (101.6 - 355.6)
- SC** STAINLESS CAST RING
4"Ø-14"Ø (101.6 - 355.6)
- BI** BLACK IRON ANGLE RING
4"Ø-120"Ø (101.6 - 3048.0)
- SS** STAINLESS ANGLE RING
16"Ø-120"Ø (406.4 - 3048.0)

METRIC EQUIVALENTS ARE SHOWN IN PARENTHESIS & ITALICS (MILLIMETERS OR AS NOTED)

Concentric and Eccentric Reducer

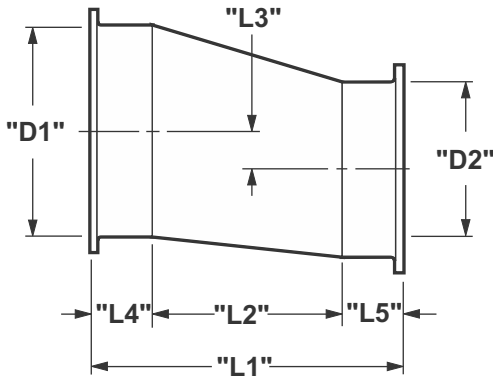

ECCENTRIC

Formula to calculate the minimum length for an eccentric reducer:

$$"L1" = "L2" + "L4" + "L5"$$

Use this chart for minimum length of "L2":
(Shorter taper or "L2" length can be fabricated, but will effect air flow.)

AMOUNT OF REDUCTION "D1" minus "D2"	MINIMUM LENGTH "L2"
6" (152.4) AND LESS	12" (304.8)
7" (177.8) TO 9" (228.6)	18" (457.2)
10" (254.0) TO 13" (330.2)	24" (609.6)
14" (355.6) TO 17" (431.8)	30" (762.0)

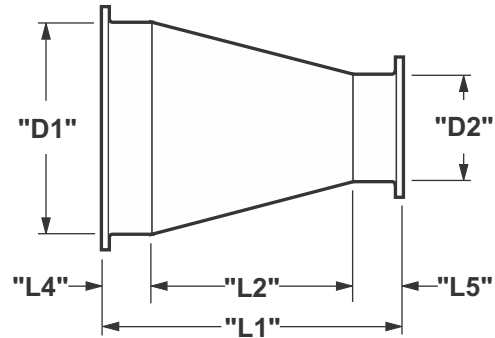

CONCENTRIC

Formula to calculate the minimum length for a concentric reducer:

$$"L1" = "L2" + "L4" + "L5"$$

Use this chart for minimum length of "L2":
(Shorter taper or "L2" length can be fabricated, but will effect air flow.)

AMOUNT OF REDUCTION "D1" minus "D2"	MINIMUM LENGTH "L2"
9" (228.6) AND LESS	12" (304.8)
10" (254.0) TO 14" (355.6)	18" (457.2)
15" (381.0) TO 19" (482.6)	24" (609.6)
20" (508.0) TO 24" (609.6)	30" (762.0)

Use this chart for minimum length of "L4" & "L5":

DUCT DIAMETER "D1" or "D2"	MINIMUM LENGTH "L4" or "L5"
4" (101.6) TO 58" (1473.2)	3" (76.2)
60" (1524.0) TO 94" (2387.6)	4" (101.6)
96" (2438.4) TO 120" (3048.0)	5" (127.0)

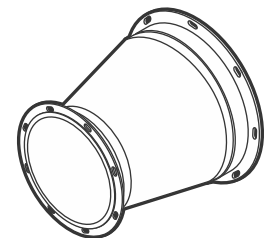

NOTES:

- SEE THE STANDARDS SECTION FOR INFORMATION ABOUT DUCT GAUGE, DUCT PRESSURE CLASSES, RING MECHANICAL SPECS, HARDWARE AND GASKETS.
- 1** **OPTION:** CUSTOM LENGTHS AVAILABLE
- DUCT GREATER THAN 84" DIA. (2133.6mm) REQUIRES FAB-TECH ENGINEERING REVIEW AND APPROVAL.
- ALL DUCT FITTINGS WITH STANDARD FAB-TECH CONNECTIONS INCLUDE GASKETS AND CLAMPS OR HARDWARE AS REQUIRED FOR INSTALLATION.

DUCT JOINT / RING TYPE

- EZ** EZ CLAMP
4"Ø-14"Ø (101.6 - 355.6)
- SC** STAINLESS CAST RING
4"Ø-14"Ø (101.6 - 355.6)
- BI** BLACK IRON ANGLE RING
4"Ø-120"Ø (101.6 - 3048.0)
- SS** STAINLESS ANGLE RING
16"Ø-120"Ø (406.4 - 3048.0)

METRIC EQUIVALENTS ARE SHOWN IN PARENTHESIS & ITALICS (MILLIMETERS OR AS NOTED)

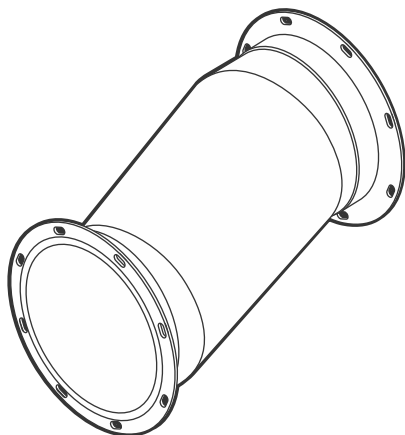

JOINT SYSTEM

EZ CLAMP	4" (101.6) - 14" (355.6)
SS CAST RING	4" (101.6) - 14" (355.6)
BI ANGLE RING	4" (101.6) - 120" (3048.0)
SS ANGLE RING	16" (406.4) - 120" (3048.0)

OR A COMBINATION OF JOINING SYSTEMS

NOTE

ALL FITTINGS WITH STANDARD FAB-TECH CONNECTIONS INCLUDE GASKETS AND CLAMPS OR HARDWARE AS REQUIRED FOR INSTALLATION.

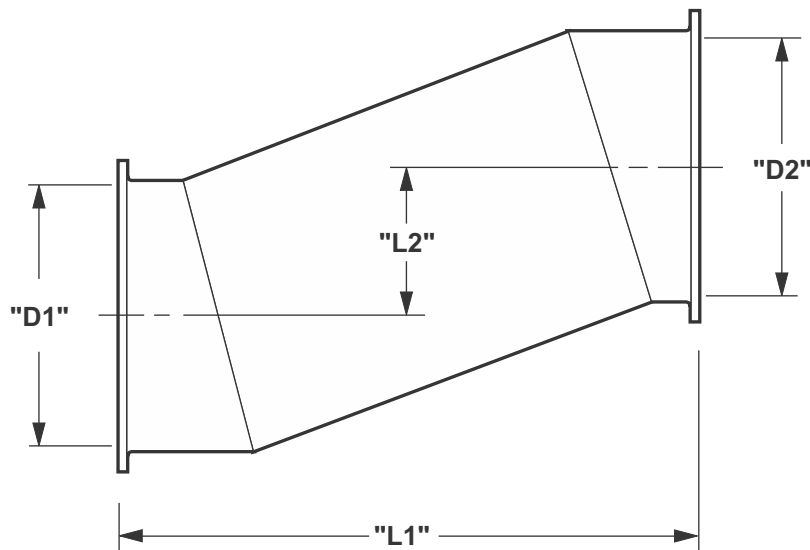

METRIC EQUIVALENTS ARE SHOWN IN PARENTHESIS & ITALICS (MILLIMETERS OR AS NOTED)

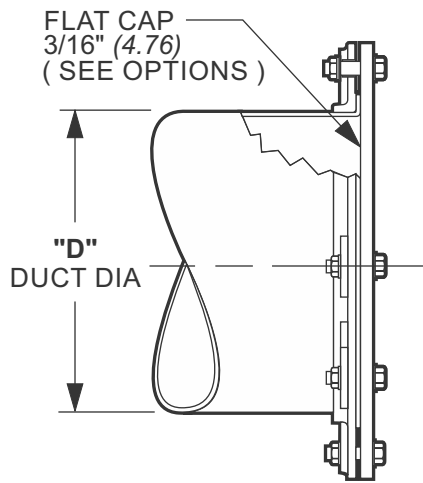

4" (101.6) - 14" (355.6)
**FLAT CAP
 CONFIGURATION**

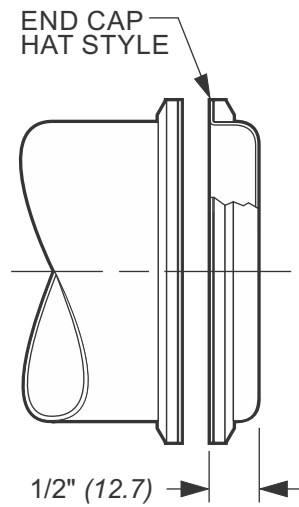

4" (101.6) - 14" (355.6)
PSP-EZ™ CONFIGURATION

NOTE

ALL FITTINGS WITH STANDARD FAB-TECH CONNECTIONS INCLUDE GASKETS AND CLAMPS OR HARDWARE AS REQUIRED FOR INSTALLATION.

OPTIONS

CLEAR POLYCARBONATE VIEWPORT ENDCAPS AVAILABLE UP TO 12" (304.8) DIA. LARGER SIZES AVAILABLE WITH ENGINEERING REVIEW AND APPROVAL.

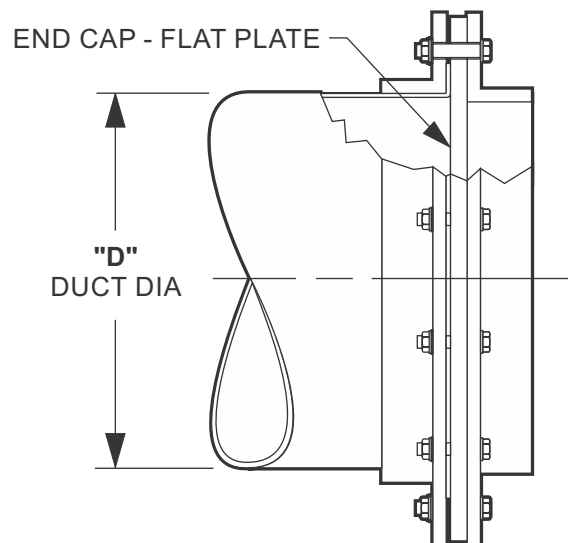

16" (406.4) - 120" (3048.0)
**ANGLE RING CONFIGURATION
 WITH ADDED SUPPORT
 ANGLE RING**

TRANSVERSE STIFFENERS REQUIRED FOR END CAPS OVER 36" (914.4) DIA.

METRIC EQUIVALENTS ARE SHOWN IN PARENTHESIS & ITALICS (MILLIMETERS OR AS NOTED)

Mesh End Cap

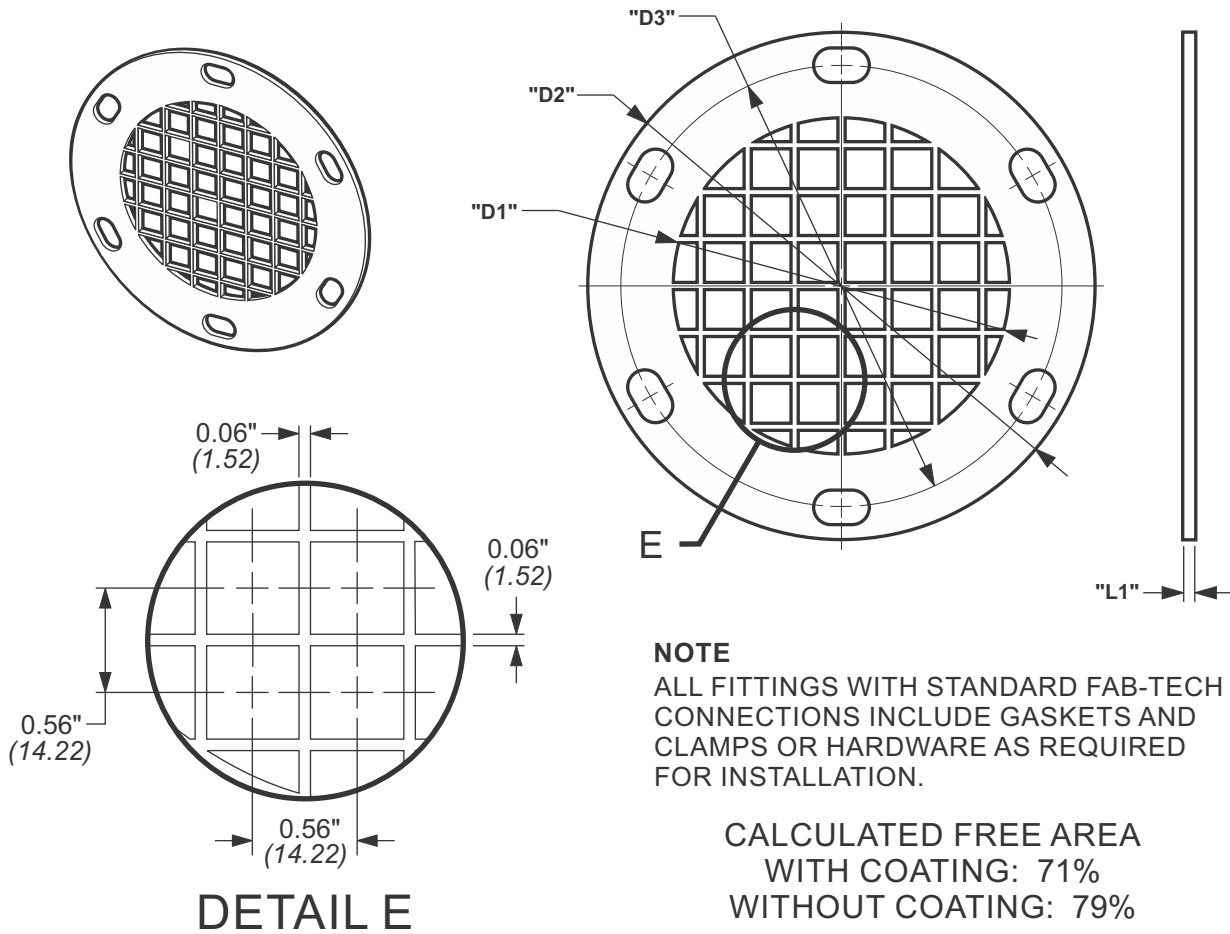

* I.D. "D1"	O.D. "D2"	BOLT HOLE DIA "D3"	THK "L1"	NO. HOLES	SLOT SIZE
4-1/16" (103.2)	6-1/16" (154.0)	5.3" (134.6)	10GA(3.57)	6	7/16" (11.11) HOLE
6-1/8" (155.6)	8-5/8" (219.1)	7.5" (190.5)	10GA(3.57)	6	7/16" x 11/16" (11.11x17.5)
8-1/8" (206.4)	10-5/8" (269.9)	9.5" (241.3)	10GA(3.57)	8	7/16" x 11/16" (11.11x17.5)
10-1/8" (257.2)	12-5/8" (320.7)	11.5" (292.1)	10GA(3.57)	8	7/16" x 11/16" (11.11x17.5)
12-3/16" (309.6)	15-3/16" (385.8)	13.81" (350.8)	10GA(3.57)	12	9/16" x 3/4" (14.29x19.5)
14-3/16" (360.4)	17-3/16" (436.6)	15.81" (401.6)	10GA(3.57)	12	9/16" x 3/4" (14.29x19.5)
16-3/16" (411.2)	19-3/16" (487.4)	17.76" (451.1)	10GA(3.57)	16	9/16" x 3/4" (14.29x19.5)
18-3/16" (462.0)	21-3/16" (538.2)	19.76" (501.9)	10GA(3.57)	16	9/16" x 3/4" (14.29x19.5)
20-3/16" (512.8)	23-3/16" (589.0)	21.76" (552.7)	10GA(3.57)	20	9/16" x 3/4" (14.29x19.5)
22-3/16" (563.6)	25-3/16" (639.8)	23.88" (606.6)	10GA(3.57)	20	9/16" x 3/4" (14.29x19.5)
24-3/16" (614.4)	27-3/16" (690.6)	25.88" (657.4)	10GA(3.57)	20	9/16" x 3/4" (14.29x19.5)
26-3/16" (665.2)	30-3/16" (766.7)	27.88" (708.2)	10GA(3.57)	24	9/16" x 3/4" (14.29x19.5)
28-3/16" (716.0)	32-3/16" (817.6)	29.88" (759.0)	10GA(3.57)	24	9/16" x 3/4" (14.29x19.5)
30-3/16" (766.7)	34-3/16" (868.4)	31.88" (809.8)	10GA(3.57)	28	9/16" x 3/4" (14.29x19.5)
32-1/16" (814.4)	36-1/16" (916.0)	33.88" (860.6)	10GA(3.57)	28	9/16" x 3/4" (14.29x19.5)
34-1/16" (865.2)	38-1/16" (966.8)	35.88" (911.4)	10GA(3.57)	32	9/16" x 3/4" (14.29x19.5)
36-1/16" (916.0)	40-1/16" (1017.6)	37.88" (962.2)	10GA(3.57)	32	9/16" x 3/4" (14.29x19.5)

* Mesh End Cap I.D. to the nearest whole number matches standard duct diameters (see Ring Mechanical Specification page).

METRIC EQUIVALENTS ARE SHOWN IN PARENTHESIS & ITALICS (MILLIMETERS OR AS NOTED)

Concentric Round to Rectangular Transition

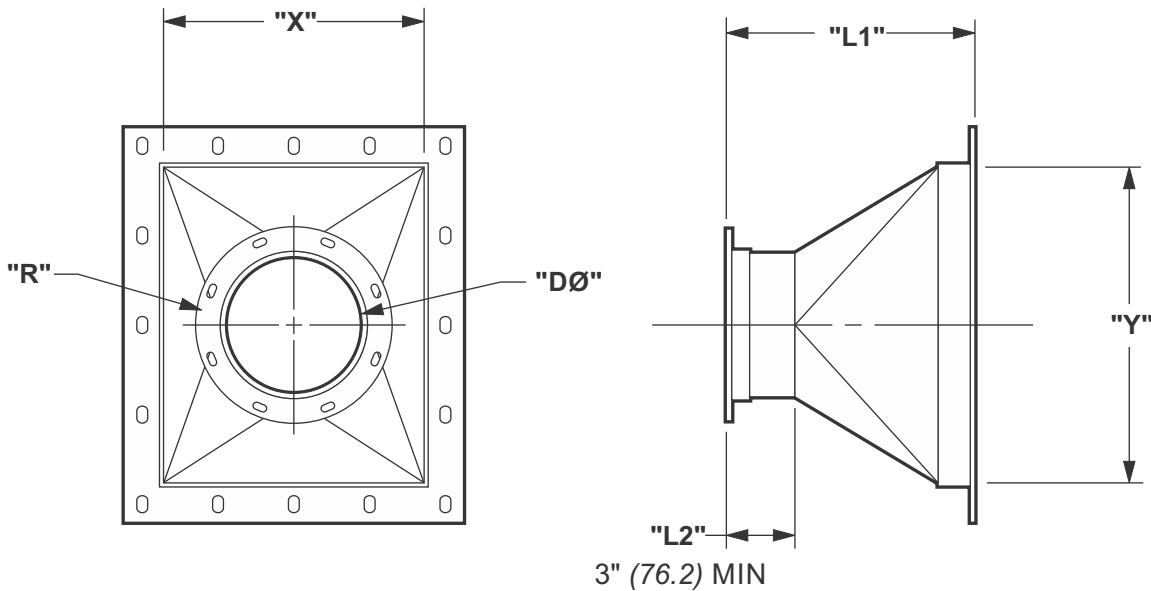
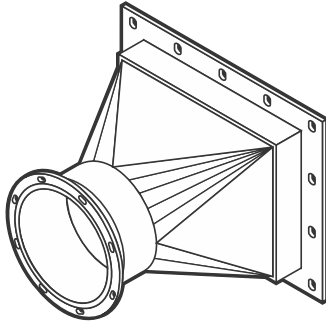

NOTES:

1. SEE THE STANDARDS SECTION OF THE PRODUCT CATALOG FOR INFORMATION ABOUT DUCT GAUGE, RING MECHANICAL SPECS, HARDWARE AND GASKETS.
2. **1 OPTION:** RAW END AVAILABLE
3. FOR ECCENTRIC RECTANGULAR TO ROUND FITTING, USE THE CUSTOM FITTING ORDER SHEET.
4. ROUND DUCT GREATER THAN 84" (2133.6) DIAMETER REQUIRES FAB-TECH ENGINEERING REVIEW AND APPROVAL.
5. RECTANGULAR DUCT WIDTH OR HEIGHT OF 98" (2489.2) AND LARGER REQUIRES FAB-TECH ENGINEERING REVIEW AND APPROVAL.
6. A CENTER STIFFENER (1" SCH40 PIPE) IS ADDED AT THE MIDPOINT OF THE FLANGE FOR RECTANGULAR DUCT WIDTH OR HEIGHT OF 50" (1270.0) AND GREATER.
7. ALL DUCT FITTINGS WITH STANDARD FAB-TECH CONNECTIONS INCLUDE GASKETS AND CLAMPS OR HARDWARE AS REQUIRED FOR INSTALLATION.

DUCT JOINT / RING TYPE FOR ROUND JOINT

- EZ** EZ CLAMP
4"Ø-14"Ø (101.6 - 355.6)
- SC** STAINLESS CAST RING
4"Ø-14"Ø (101.6 - 355.6)
- BI** BLACK IRON ANGLE RING
4"Ø-120"Ø (101.6 - 3048.0)
- SS** STAINLESS ANGLE RING
16"Ø-120"Ø (406.4 - 3048.0)

METRIC EQUIVALENTS ARE SHOWN IN PARENTHESIS & ITALICS (MILLIMETERS OR AS NOTED)

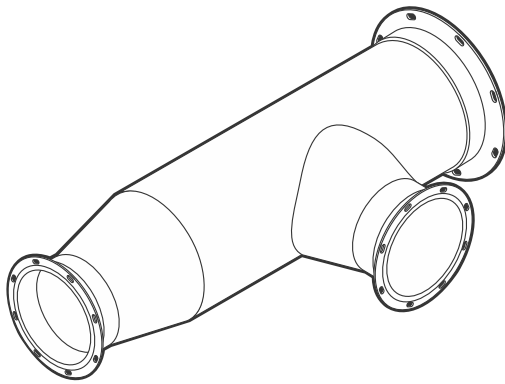

90 DEGREE REDUCING TEE

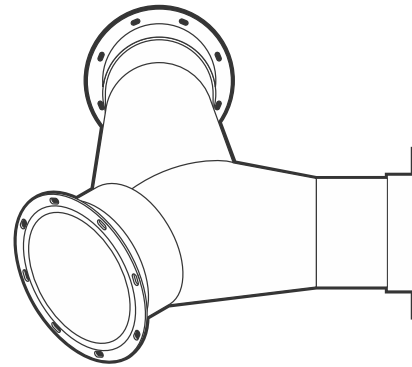

90 DEGREE WYE

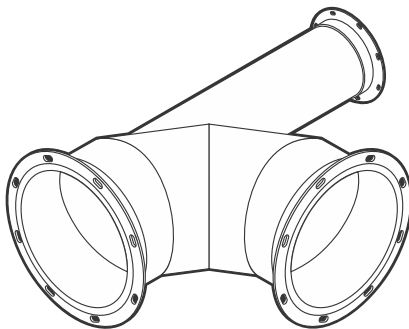

ELBOW WITH HEEL TAP

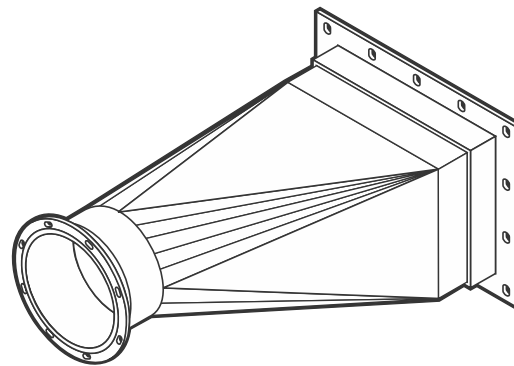

ECCENTRIC ROUND TO RECTANGULAR TRANSITION





NOTES:

1. SEE THE STANDARDS SECTION OF THE PRODUCT CATALOG FOR INFORMATION ABOUT DUCT GAUGE, RING MECHANICAL SPECS, HARDWARE AND GASKETS.
2. USE THE CUSTOM FITTING ORDER SHEET TO DESCRIBE YOUR FITTING.
3. ROUND DUCT GREATER THAN 84" (2133.6) DIAMETER REQUIRES FAB-TECH ENGINEERING REVIEW AND APPROVAL.
4. RECTANGULAR DUCT WIDTH OR HEIGHT OF 98" (2489.2) AND LARGER REQUIRES FAB-TECH ENGINEERING REVIEW AND APPROVAL.
5. ALL DUCT FITTINGS WITH STANDARD FAB-TECH CONNECTIONS INCLUDE GASKETS AND CLAMPS OR HARDWARE AS REQUIRED FOR INSTALLATION.

DUCT JOINT / RING TYPE FOR ROUND JOINT

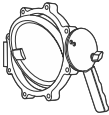
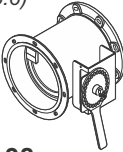
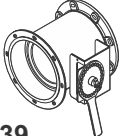
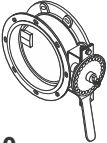
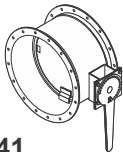
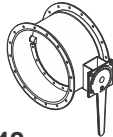
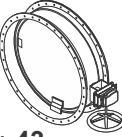
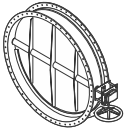
- EZ** EZ CLAMP
4"Ø-14"Ø (101.6 - 355.6)
- SC** STAINLESS CAST RING
4"Ø-14"Ø (101.6 - 355.6)
- BI** BLACK IRON ANGLE RING
4"Ø-120"Ø (101.6 - 3048.0)
- SS** STAINLESS ANGLE RING
16"Ø-120"Ø (406.4 - 3048.0)

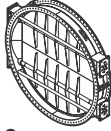
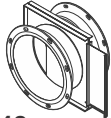
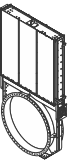
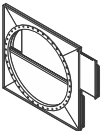
METRIC EQUIVALENTS ARE SHOWN IN PARENTHESIS & ITALICS (MILLIMETERS OR AS NOTED)

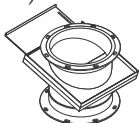
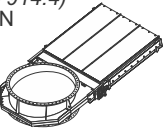
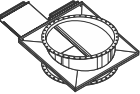
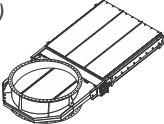
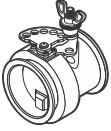
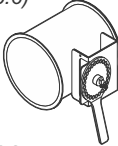
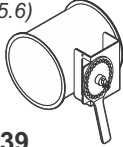
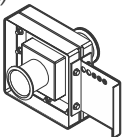
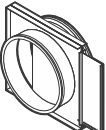
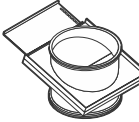
<p>CONTROL DEVICES</p>	<p>4"-12" (101.6-304.8) WAFER ISOLATION DAMPER</p>  <p>• PAGE: 36</p>	<p>4"-14" (101.6 - 355.6) INDUSTRIAL ISOLATION DAMPER</p>  <p>• PAGE: 38</p>	<p>6"-14" (152.4 - 355.6) INDUSTRIAL ISOLATION DAMPER AMCA</p>  <p>• PAGE: 39</p>
<p>4"-14" (101.6 - 355.6) INDUSTRIAL ISOLATION SHORT DAMPER</p>  <p>• PAGE: 40</p>	<p>16"-34" (406.4 - 863.6) HIGH VALUE HEAVY DUTY INDUSTRIAL DAMPER AMCA</p>  <p>• PAGE: 41</p>	<p>16"-48" (406.4 - 1219.2) HIGH VALUE HEAVY DUTY INDUSTRIAL DAMPER (HVD)</p>  <p>• PAGE: 42</p>	<p>36"-48" (914.4 - 1219.2) HIGH VALUE HEAVY DUTY INDUSTRIAL DAMPER AMCA</p>  <p>• PAGE: 43</p>
<p>50" & LARGER (1270.0 - 3048.0) HEAVY DUTY INDUSTRIAL DAMPER</p>  <p>• PAGE: 44</p>	<p>24"-84" (609.6 - 2133.6) ULTRA SERIES INDUSTRIAL DAMPER</p>  <p>• PAGE: 45</p>	<p>86"-120" (2184.4 - 3048.0) ULTRA SERIES DUAL BLADE INDUSTRIAL DAMPER</p>  <p>• PAGE: 46</p>	<p>4"-36" (101.6 - 914.4) HORIZONTAL RUN BLASTGATE</p>  <p>• PAGE: 48</p>
<p>16"-36" (406.4 - 914.4) HORIZONTAL RUN ACTUATED BLASTGATE</p>  <p>• PAGE: 49</p>	<p>38" & LARGER (965.2 - 3048.0) HORIZONTAL RUN BLASTGATE</p>  <p>• PAGE: 50</p>	<p>38" & LARGER (965.2 - 3048.0) HORIZONTAL RUN ACTUATED BLASTGATE</p>  <p>• PAGE: 51</p>	<p>4"-36" (101.6 - 914.4) VERTICAL RUN ISOLATION BLASTGATE</p>  <p>• PAGE: 52</p>
<p>16"-36" (406.4 - 914.4) VERTICAL RUN ACTUATED BLASTGATE</p>  <p>• PAGE: 53</p>	<p>38" & LARGER (965.2 - 3048.0) VERTICAL RUN ISOLATION BLASTGATE</p>  <p>• PAGE: 54</p>	<p>38" & LARGER (965.2 - 3048.0) VERTICAL RUN ACTUATED BLASTGATE</p>  <p>• PAGE: 55</p>	
<p>CONTROL DEVICES PSP-EZ™</p>	<p>2" & 3" (50.8 & 76.2) MICRO ADJUSTABLE EZ DAMPER</p>  <p>• PAGE: 37</p>	<p>4" - 14" (101.6 - 355.6) INDUSTRIAL ISOLATION DAMPER</p>  <p>• PAGE: 38</p>	<p>AMCA 6" - 14" (152.4 - 355.6) INDUSTRIAL ISOLATION DAMPER</p>  <p>• PAGE: 39</p>
	<p>2" & 3" (50.8 & 76.2) HORIZONTAL RUN & VERTICAL RUN EZ BLASTGATE</p>  <p>• PAGE: 47</p>	<p>4" - 14" (101.6 - 355.6) HORIZONTAL RUN BLASTGATE</p>  <p>• PAGE: 48</p>	<p>4" - 14" (101.6 - 355.6) VERTICAL RUN BLASTGATE</p>  <p>• PAGE: 52</p>

METRIC EQUIVALENTS ARE SHOWN IN PARENTHESIS & ITALICS (MILLIMETERS OR AS NOTED)

Round Damper Comparison Chart

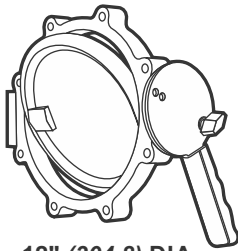

**4" (101.6) - 12" (304.8) DIA
WAFER ISOLATION
DAMPER**

BODY: COATED SOLID ALUMINUM BODY
BODY LENGTH: 1" (25.4)
COATING: PERMASHIELD FLUOROPOLYMER BARRIER COATING
BLADE: COATED 10GA (3.57) STAINLESS STEEL WITH FULLY WELDED DRIVE AXLE
4"Ø BLADE: MACHINED PTFE
EDGE SEALS: VITON EXTRUDED RUBBER
BLADE HOLDERS: MOLDED 25% GLASS FILLED PTFE
AXLE: DUAL SHAFT 1/2" (12.7) DIA STAINLESS STEEL
AXLE SEALS: LIQUID TIGHT - POS & NEG SYSTEM PRESSURE
BEARINGS: NYLON
COATING: FLUOROPOLYMER BARRIER COATING
QUADRANT: MANUAL LOCKING HANDLE
LOCKOUT: 1/2° INTERVALS
BLADE OPENS: CW
OPEN/CLOSE TORQUE: 250 in-lb (28.25 N-m) RECOMMENDED MINIMUM

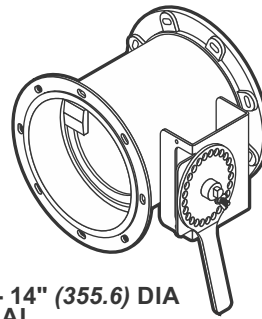

**4" (101.6) - 14" (355.6) DIA
INDUSTRIAL
ISOLATION DAMPER**

BODY: COATED 20GA (0.95) STAINLESS STEEL
BODY LENGTH: 9-1/4" (235.0)
OPTION: CUSTOM LENGTH
COATING: PERMASHIELD FLUOROPOLYMER BARRIER COATING
JOINING SYSTEM: FLOATING CAST STAINLESS STEEL RINGS
OPTION: PSP-EZ™ JOINING SYSTEM 4"-14"
OPTION: FLOATING BLACK IRON ANGLE RINGS 6" (152.4) - 14" (355.6)
OPTION: CUSTOM HOLE PATTERN
BLADE: VIRGIN TEFLON 4" (101.6) 10GA (3.57) COATED SS 6"-14" (152.4-355.6)
EDGE SEALS: FLUOROELASTOMER
BLADE HOLDERS: VIRGIN TEFLON 4" (101.6) ISOLATION MOLDED PTFE 6"-14" (152.4-355.6) ISOLATION
AXLES: DUAL SHAFT 1/2" (12.7) DIA STAINLESS STEEL
AXLE SEALS: LIQUID TIGHT
ACTUATOR: MANUAL LEVER
OPTION: ELECTRIC ACTUATOR (SS RINGS)
OPTION: PNEUMATIC ACTUATOR (SS RINGS) (ACTUATORS ONLY AVAILABLE W/ SS RINGS)
LOCKOUT: 1/2° INTERVALS
BLADE OPENS: CCW
OPEN/CLOSE TORQUE: 250 in-lb (28.25 N-m) RECOMMENDED MINIMUM

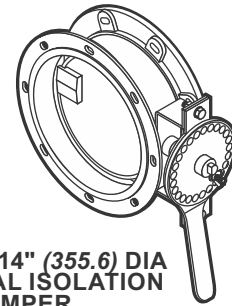

**4" (101.6) - 14" (355.6) DIA
INDUSTRIAL ISOLATION
SHORT DAMPER**

BODY: COATED 20GA (0.95) STAINLESS STEEL
BODY LENGTH: 4" (101.6) MIN W/ EZ FLANGES 4-1/2" (114.3) MIN W/ CAST & FLAT RINGS
OPTION: CUSTOM LENGTH
COATING: PERMASHIELD FLUOROPOLYMER BARRIER COATING
JOINING SYSTEM: FLOATING CAST STAINLESS STEEL RINGS
OPTION: FLOATING STAINLESS STEEL FLAT RINGS 4" (101.6) - 14" (355.6)
OPTION: FLOATING BLACK IRON FLAT RINGS 4" (101.6) - 14" (355.6)
OPTION: PSP-EZ™ JOINING SYSTEM 4" (101.6) - 14" (355.6)
OPTION: CUSTOM HOLE PATTERN
BLADE: 4" (101.6): VIRGIN TEFLON 6" (152.4) - 14" (355.6): 10GA (3.57) COATED STAINLESS STEEL
EDGE SEALS: FLUOROELASTOMER
BLADE HOLDERS: MOLDED PTFE
AXLES: DUAL SHAFT 1/2" (12.7) DIA STAINLESS STEEL
AXLE SEALS: LIQUID TIGHT
ACTUATOR: MANUAL LEVER
LOCKOUT: 1/2° INTERVALS
BLADE OPENS: CCW
OPEN/CLOSE TORQUE: 1000 in-lb (113.0 N-m) RECOMMENDED MINIMUM

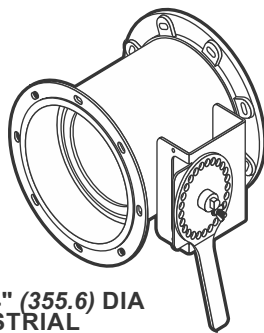

**6" (152.4) - 14" (355.6) DIA
AMCA INDUSTRIAL
ISOLATION DAMPER**

BODY: COATED 20GA (0.95) STAINLESS STEEL
BODY LENGTH: 9-1/4" (235.0)
OPTION: CUSTOM LENGTH
COATING: PERMASHIELD FLUOROPOLYMER BARRIER COATING
JOINING SYSTEM: FLOATING CAST STAINLESS STEEL RINGS
OPTION: PSP-EZ™ JOINING SYSTEM 6" (152.4) - 14" (355.6)
OPTION: FLOATING BLACK IRON ANGLE RINGS 6" (152.4) - 14" (355.6)
OPTION: CUSTOM HOLE PATTERN
BLADE: OFFSET - 10GA (3.57) COATED STAINLESS STEEL
EDGE SEALS: VITON
BLADE HOLDERS: MOLDED PTFE
AXLES: DUAL SHAFT 1/2" (12.7) DIA STAINLESS STEEL
AXLE SEALS: LIQUID TIGHT
ACTUATOR: MANUAL LEVER
OPTION: ELECTRIC ACTUATOR (SS RINGS)
OPTION: PNEUMATIC ACTUATOR (SS RINGS) (ACTUATORS ONLY AVAILABLE W/ SS RINGS)
LOCKOUT: 1/2° INTERVALS
BLADE OPENS: CCW
OPEN/CLOSE TORQUE: 250 in-lb (28.25 N-m) RECOMMENDED MINIMUM

METRIC EQUIVALENTS ARE SHOWN IN PARENTHESIS & ITALICS (MILLIMETERS OR AS NOTED)

Round Damper Comparison Chart

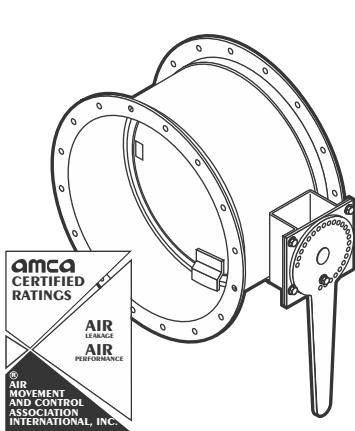

**16" (406.4) - 34" (863.6) DIA
AMCA HIGH VALUE HEAVY DUTY
INDUSTRIAL DAMPER**

DIFFERENTIAL PRESSURE: 10" WG (2.491 kPa)
BODY: COATED 12GA (2.78) STAINLESS STEEL
BODY LENGTH: 10" (254.0)
COATING: PERMASHIELD FLUOROPOLYMER BARRIER COATING
JOINING SYSTEM: STITCH WELDED COATED BLACK IRON VAN STONE RINGS
OPTION: CUSTOM HOLE PATTERN
MOUNTING HOLES: STRADDLE VERTICAL CENTERLINE
BLADE: OFFSET - 1/4" (6.35) COATED STAINLESS STEEL
BLADE EDGE SEAL: VITON
BLADE STOPS: WELDED
AXLES: DUAL SHAFT 1.38 (34.9) DIA SS
AXLE SEALS: LIQUID TIGHT
SLEEVE BEARINGS: THERMOPLASTIC
ACTUATOR: MANUAL LEVER
OPTION: MANUAL GEAR BOX W/ LOCK OUT
OPTION: CUSTOM ACTUATOR MOUNTING KIT
OPTION: ELECTRIC ACTUATOR
OPTION: PNEUMATIC ACTUATOR
LOCKOUT: 1/2° INTERVALS
BLADE OPENS: CCW
OPEN/CLOSE TORQUE: 1000 in-lb (113.0 N-m) RECOMMENDED MINIMUM

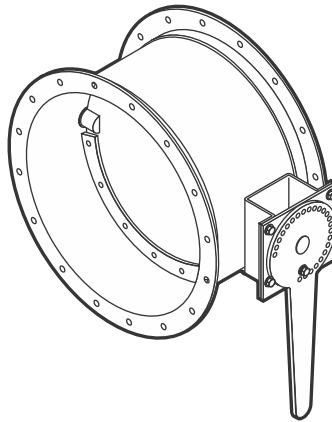

**16" (406.4) - 48" (1219.2) DIA
HIGH VALUE HEAVY DUTY
INDUSTRIAL DAMPER (HVD)**

DIFFERENTIAL PRESSURE: 10" WG (2.491 kPa)
BODY: COATED 12GA (2.78) STAINLESS STEEL
BODY LENGTH: 10" (254.0)
COATING: PERMASHIELD FLUOROPOLYMER BARRIER COATING
JOINING SYSTEM: STITCH WELDED COATED BLACK IRON VAN STONE RINGS
OPTION: CUSTOM HOLE PATTERN
OPTION: STITCH WELDED STAINLESS STEEL VAN STONE RINGS
MOUNTING HOLES: STRADDLE VERTICAL CENTERLINE
BLADE: 1/4" (6.35) COATED STAINLESS STEEL
BLADE STOPS: WELDED W/ VITON BLADE SEAL
AXLES: DUAL SHAFT 1.38 (34.9) DIA SS
AXLE SEALS: LIQUID TIGHT
SLEEVE BEARINGS: THERMOPLASTIC
ACTUATOR: MANUAL LEVER
OPTION: MANUAL GEAR BOX W/ LOCK OUT
OPTION: CUSTOM ACTUATOR MOUNTING KIT
OPTION: ELECTRIC ACTUATOR
OPTION: PNEUMATIC ACTUATOR
LOCKOUT: 1/2° INTERVALS
BLADE OPENS: CCW
OPEN/CLOSE TORQUE: 1000 in-lb (113.0 N-m) RECOMMENDED MINIMUM

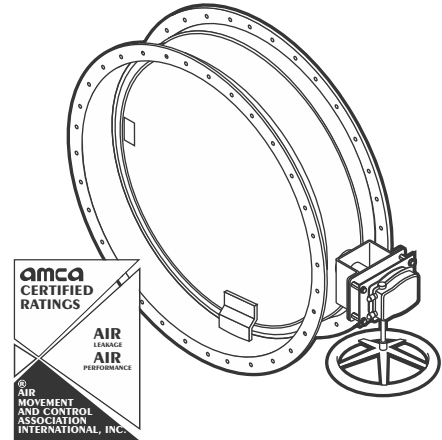

**36" (914.4) - 48" (1219.2) DIA
AMCA HIGH VALUE HEAVY DUTY
INDUSTRIAL DAMPER**

DIFFERENTIAL PRESSURE: 10" WG (2.491 kPa)
BODY: COATED 12GA (2.78) STAINLESS STEEL
BODY LENGTH: 10" (254.0)
COATING: PERMASHIELD FLUOROPOLYMER BARRIER COATING
JOINING SYSTEM: STITCH WELDED COATED BLACK IRON VAN STONE RINGS
OPTION: CUSTOM HOLE PATTERN
MOUNTING HOLES: STRADDLE VERTICAL CENTERLINE
BLADE: OFFSET - 1/4" (6.35) COATED STAINLESS STEEL
BLADE EDGE SEAL: VITON
BLADE STOPS: WELDED
AXLES: DUAL SHAFT 1.38 (34.9) DIA SS
AXLE SEALS: LIQUID TIGHT
SLEEVE BEARINGS: THERMOPLASTIC
ACTUATOR: MANUAL GEAR BOX W/ LOCK OUT
OPTION: CUSTOM ACTUATOR MOUNTING KIT
OPTION: ELECTRIC ACTUATOR
OPTION: PNEUMATIC ACTUATOR
LOCKOUT: 1/2° INTERVALS
BLADE OPENS: CCW
OPEN/CLOSE TORQUE: 1000 in-lb (113.0 N-m) RECOMMENDED MINIMUM

METRIC EQUIVALENTS ARE SHOWN IN PARENTHESIS & ITALICS (MILLIMETERS OR AS NOTED)

Round Damper Comparison Chart

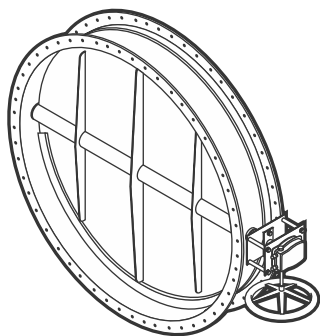

50" (1270.0) DIA. & LARGER REINFORCED HEAVY DUTY INDUSTRIAL DAMPER

DIFFERENTIAL PRESSURE: 10" WG (2.491 kPa)
BODY: COATED 1/4" (6.35) STAINLESS STEEL
OPTION: AVAIL TO 120" (3048.0) DIA W/ ENGINEERING REVIEW
BODY LENGTH: 10" (254.0)
COATING: PERMASHIELD FLUOROPOLYMER BARRIER COATING
JOINING SYSTEM: FULLY WELDED STAINLESS STEEL VAN STONE RINGS
OPTION: CUSTOM HOLE PATTERN
MOUNTING HOLES: STRADDLE VERTICAL CENTERLINE
BLADE: 3/8" (9.5) COATED REINFORCED STAINLESS STEEL
BLADE STOPS: WELDED
AXLES: DUAL SHAFT 1.85 (46.99) DIA STAINLESS STEEL
AXLE SEALS: LIQUID TIGHT
SLEEVE BEARINGS: THERMOPLASTIC
ACTUATOR: GEAR ACTUATOR W/ LOCK OUT
OPTION: CUSTOM ACTUATOR MOUNTING KIT
OPTION: ELECTRIC ACTUATOR
OPTION: PNEUMATIC ACTUATOR

PNEUMATIC ACTUATED DAMPERS HYTORC ACTUATOR STANDARD

XL45 - UP TO 20" (508.0)
 XL280 - 21" (533.4) TO 48" (1219.2)
 XL425 - 49" (1244.6) TO 94" (2387.6)

LOCKOUT: 1/2" INTERVALS
BLADE OPENS: CCW
OPEN/CLOSE TORQUE: 1600 in-lb (180.78 N-m) RECOMMENDED MIN

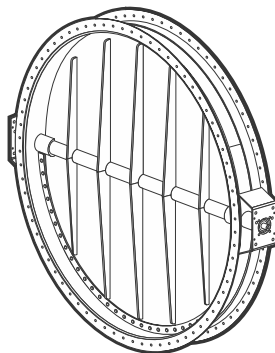

24" (609.6) - 84" (2133.6) DIA. ULTRA SERIES INDUSTRIAL DAMPER

DIFFERENTIAL PRESSURE: 30" WG (7.473 kPa)
BODY: COATED 24" - 44" (609.6 - 1117.6) DIA. 10GA (3.57) STAINLESS STEEL
 COATED 46" - 84" (1168.4 - 2133.6) DIA. 1/4" (6.35) STAINLESS STEEL
OPTION: AVAIL TO 120" (3048.0) DIA W/ ENGINEERING REVIEW
BODY LENGTH: 10" (254.0)
COATING: PERMASHIELD FLUOROPOLYMER BARRIER COATING
JOINING SYSTEM: FULLY WELDED STAINLESS STEEL VAN STONE RINGS
OPTION: CUSTOM HOLE PATTERN
MOUNTING HOLES: STRADDLE VERTICAL CENTERLINE
BLADE: COATED REINFORCED
 24" - 58" (609.6 - 1473.2) DIA. 1/4" (6.35) STAINLESS STEEL
 60" - 84" (1524.0 - 2133.6) DIA. 3/8" (9.5) STAINLESS STEEL
BLADE STOPS: WELDED
AXLES: 24" - 44" (609.6 - 1117.6) DIA. DUAL SHAFT 1.20 (30.5) DIA SS
 46" - 58" (1168.4 - 1473.2) DIA. DUAL SHAFT 1.85 (47.0) DIA SS
 60" & UP (152.4) DIA. DUAL SHAFT 2.45 (62.2) DIA SS
AXLE SEALS: LIQUID TIGHT
SLEEVE BEARINGS: BRONZE SLEEVE [24" - 58" (609.6 - 1473.2)] SPHERICAL HEIM [60" - 84" (1524.0 - 2133.6)]
ACTUATOR: NONE; STANDARD INTERFACE FOR ROTORK HIGH SPEED SI-1-Q SERIES
OPTION: CUSTOM ACTUATOR MOUNTING KIT
OPTION: ELECTRIC ACTUATOR
OPTION: PNEUMATIC ACTUATOR
LOCKOUT: VARIABLE POSITION
BLADE POSITION INDICATOR: IDLE SIDE
BLADE OPENS: CCW

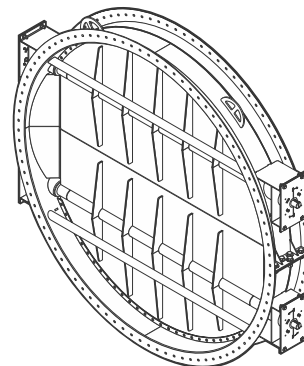

86" (2184.4) - 120" (3048.0) DIA. ULTRA SERIES DUAL BLADE INDUSTRIAL DAMPER

DIFFERENTIAL PRESSURE: 30" WG (7.473 kPa)
BODY: COATED 1/4" (6.35) STAINLESS STEEL
BODY LENGTH: 14.5" (368.3)
COATING: PERMASHIELD FLUOROPOLYMER BARRIER COATING
JOINING SYSTEM: FULLY WELDED STAINLESS STEEL VAN STONE RINGS
OPTION: CUSTOM HOLE PATTERN
MOUNTING HOLES: STRADDLE VERTICAL CENTERLINE
BLADE: COATED REINFORCED 3/8" (9.5) STAINLESS STEEL
BLADE STOPS: WELDED
AXLES: DUAL SHAFT 2.00 (50.8) DIA SS
AXLE SEALS: LIQUID TIGHT
BEARINGS: SPHERICAL HEIM
ACTUATOR: NONE, F14 / FA14 MOUNTING PATTERN
OPTION: CUSTOM ACTUATOR MOUNTING KIT
LOCKOUT: VARIABLE POSITION
BLADE POSITION INDICATOR: IDLE SIDE
BLADE OPENS: CW (TOP) - CCW (BOTTOM)

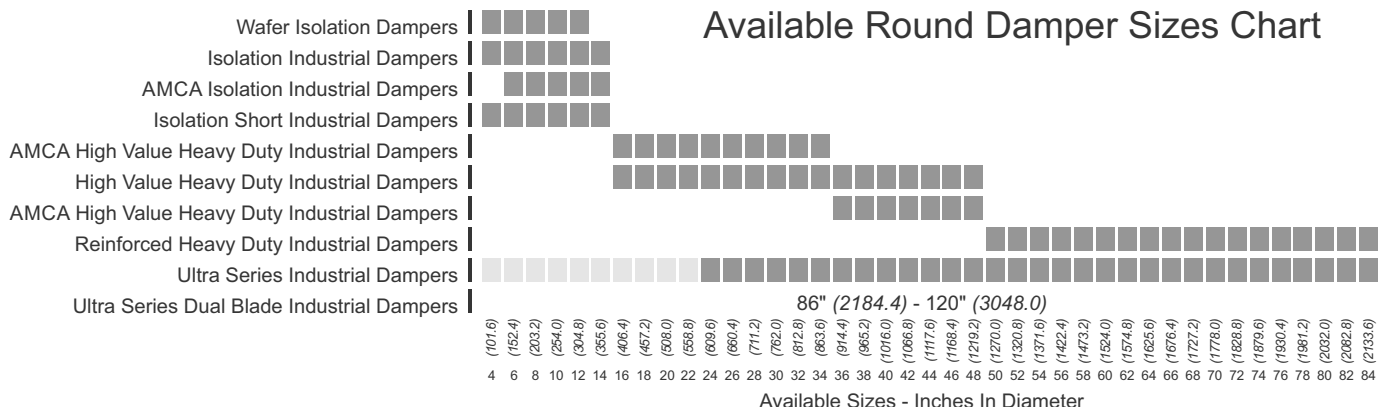

METRIC EQUIVALENTS ARE SHOWN IN PARENTHESIS & ITALICS (MILLIMETERS OR AS NOTED)

4" (101.6) - 14" (355.6) Wafer Isolation Damper

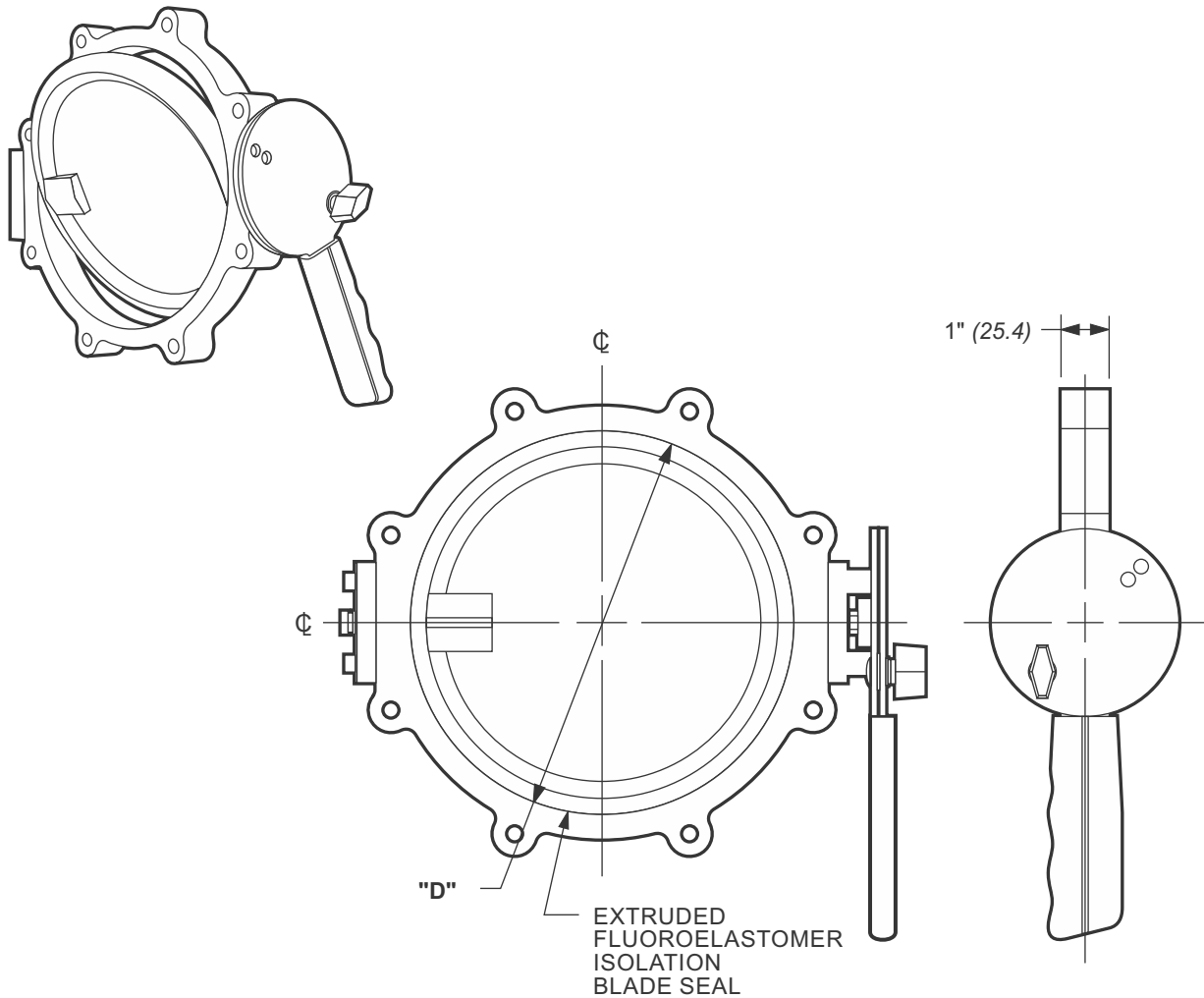

SPECIFICATIONS

BODY: COATED SOLID ALUMINUM BODY
BODY LENGTH: 1" (25.4)
COATING: PERMASHIELD FLUOROPOLYMER BARRIER COATING
BLADE: COATED 10GA (3.57) STAINLESS STEEL WITH FULLY WELDED DRIVE AXLE
4"Ø (101.6) BLADE: MACHINED PTFE
EDGE SEALS: VITON EXTRUDED RUBBER
BLADE HOLDERS: MOLDED 25% GLASS FILLED PTFE
 DUAL SHAFT 1/2"Ø 33 STAINLESS STEEL
AXLE SEALS: LIQUID TIGHT - POS & NEG SYSTEM PRESSURE
BEARINGS: NYLON
COATING: FLUOROPOLYMER BARRIER COATING
QUADRANT: MANUAL LOCKING HANDLE
LOCKOUT: 1/2° INTERVALS
BLADE OPENS: CW
OPEN/CLOSE TORQUE: 250 in-lb (28.25 N-m) RECOMMENDED MIN

BOLT HOLE SPECIFICATIONS

DUCT DIA "D"	NO. OF HOLES	BOLT HOLE SIZE	BOLT SIZE	BOLT CIRCLE DIA.
4 (50.8)	6	7/16 (11.1)	3/8 (9.53)	5.31 (134.87)
6 (152.4)				7.50 (190.5)
8 (203.2)	8	9/16 (14.2)	1/2 (12.7)	9.50 (241.3)
10 (254.0)				11.50 (292.1)
12 (304.8)	12	9/16 (14.2)	1/2 (12.7)	13.81 (350.77)
14 (355.6)				15.81 (401.57)

NOTES:

1. ALL DUCT FITTINGS WITH STANDARD FAB-TECH CONNECTIONS INCLUDE GASKETS AND CLAMPS OR HARDWARE AS REQUIRED FOR INSTALLATION.

METRIC EQUIVALENTS ARE SHOWN IN PARENTHESIS & ITALICS (MILLIMETERS OR AS NOTED)

2" (50.8) & 3" (76.2) Micro-Adjustable EZ Damper

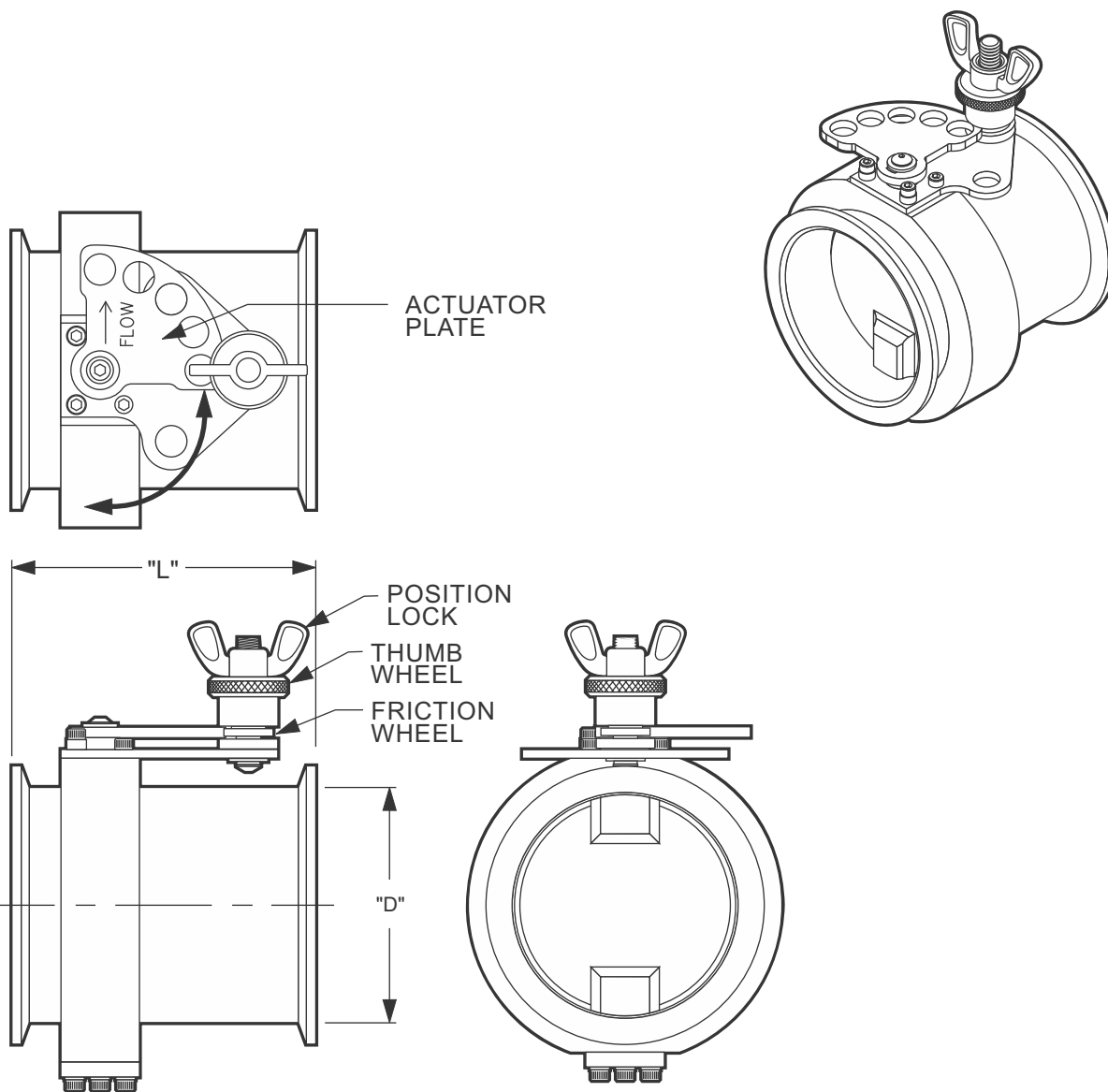

PART NO.	DESCRIPTION	"D"	"L"
PZD02	2" EZ-DAMPER	2" (50.8)	3.875" (98.43)
PZD03	3" EZ-DAMPER	3" (76.2)	3.875" (98.43)

NOTES:

1. ALL DUCT FITTINGS WITH STANDARD FAB-TECH CONNECTIONS INCLUDE GASKETS AND CLAMPS OR HARDWARE AS REQUIRED FOR INSTALLATION.

METRIC EQUIVALENTS ARE SHOWN IN PARENTHESIS & ITALICS (MILLIMETERS OR AS NOTED)

4" (101.6) - 14" (355.6) Industrial Isolation Damper

SPECIFICATIONS

- BODY:** COATED 20GA (0.95) STAINLESS STEEL
- BODY LENGTH:** 9-1/4" (234.9)
- OPTION:** CUSTOM LENGTH
- COATING:** PERMASHIELD FLUOROPOLYMER BARRIER COATING
- JOINING SYSTEM:** FLOATING CAST STAINLESS STEEL RINGS
- OPTION:** EZ JOINING SYSTEM 4" (101.6) - 14" (355.6)
- OPTION:** FLOATING BLACK IRON ANGLE RINGS 6" (152.4) - 14" (355.6)
- OPTION:** CUSTOM HOLE PATTERN
- BLADE:** VIRGIN TEFLON 4" (101.6)
- 10GA (3.57) COATED STAINLESS STEEL 6"-14" (152.4-355.6)
- EDGE SEALS:** FLUOROELASTOMER
- BLADE HOLDERS:** VIRGIN TEFLON 4" (101.6) ISOLATION
- MOLDED PTFE 6" (152.4) - 14" (355.6) ISOLATION
- AXLES:** DUAL SHAFT 1/2" (12.7) DIA. STAINLESS STEEL
- AXLE SEALS:** LIQUID TIGHT
- ACTUATOR:** MANUAL LEVER
- OPTION:** ELECTRIC ACTUATOR (SS ANGLE RINGS ONLY)
- OPTION:** PNEUMATIC ACTUATOR (SS ANGLE RINGS ONLY)
- LOCKOUT:** 1/2° INTERVALS
- BLADE OPENS:** CCW
- OPEN/CLOSE TORQUE:** 250 in-lb (28.25 N-m) RECOMMENDED MIN

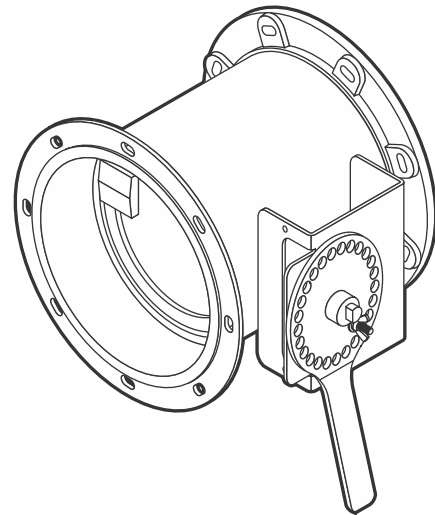

NOTES:

1. ALL DUCT FITTINGS WITH STANDARD FAB-TECH CONNECTIONS INCLUDE GASKETS AND CLAMPS OR HARDWARE AS REQUIRED FOR INSTALLATION.

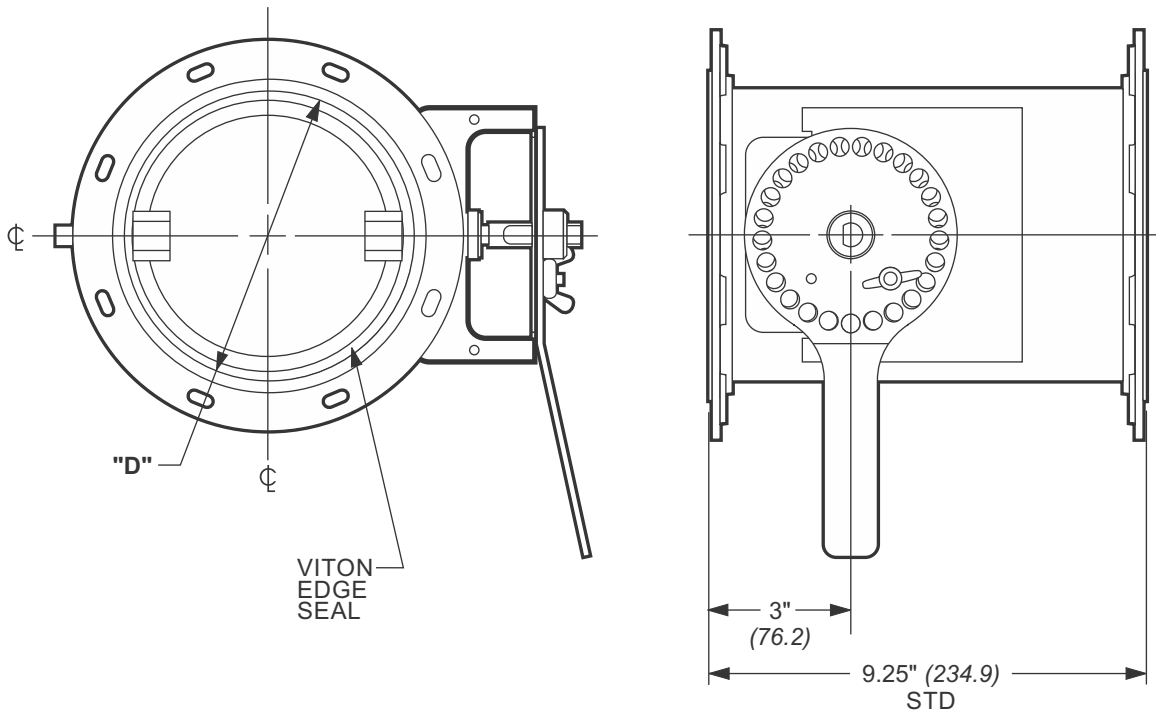

METRIC EQUIVALENTS ARE SHOWN IN PARENTHESIS & ITALICS (MILLIMETERS OR AS NOTED)

6" (152.4) - 14" (355.6) AMCA Industrial Isolation Damper

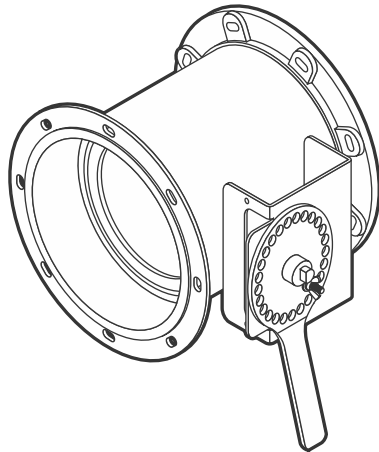

FAB-TECH, INC. CERTIFIES THAT THE INDUSTRIAL SINGLE BLADE ISOLATION DAMPER SHOWN HEREIN IS LICENSED TO BEAR THE AMCA SEAL. THE RATINGS SHOWN ARE BASED ON TESTS AND PROCEURES PERFORMED IN ACCORDANCE WITH AMCA PUB 511 AND COMPLY W/ THE REQUIREMENTS OF THE AMCA CERTIFIED RATINGS PROGRAM.

THE AMCA CERTIFIED RATINGS SEAL APPLIES TO AIR LEAKAGE RATINGS AND AIR PERFORMANCE RATINGS.

1. TEST METHOD PER AMCA STANDARD 500-89
DATA BASED ON A SEATING TORQUE OF: 764 in-lbf/ft² FOR 6" (152.4) DAMPER, 234 in-lbf/ft² FOR 14" DAMPER
2. AIR LEAKAGE IS BASED ON OPERATION BETWEEN 50° F & 104° F (10° C TO 40° C) AND DATA CORRECTED TO REPRESENT STANDARD AIR DENSITY 0.075 lbs/ft³

SPECIFICATIONS

BODY: COATED 20GA (0.95) STAINLESS STEEL

BODY LENGTH: 9-1/4" (234.9)

OPTION: CUSTOM LENGTH

COATING: PERMASHIELD FLUOROPOLYMER BARRIER COATING

JOINING SYSTEM: FLOATING CAST STAINLESS STEEL RINGS

OPTION: EZ JOINING SYSTEM 6" (152.4) - 14" (355.6)

OPTION: FLOATING BLACK IRON ANGLE RINGS
6" (152.4) - 14" (355.6)

OPTION: CUSTOM HOLE PATTERN

BLADE: OFFSET - 10GA (3.57) COATED STAINLESS STEEL

BLADE EDGE SEAL: FLUROELASTOMER

BLADE HOLDERS: MOLDED PTFE

AXLES: DUAL SHAFT 1/2" (12.7) DIA. STAINLESS STEEL

AXLE SEALS: LIQUID TIGHT

ACTUATOR: MANUAL LEVER

OPTION: ELECTRIC ACTUATOR

OPTION: PNEUMATIC ACTUATOR

LOCKOUT: 1/2° INTERVALS

BLADE OPENS: CCW

Damper Dia.	Pressure	AMCA Leakage Class
6" - 14" (152.4 - 355.6)	1"WG	1A
	4",8",12"WG	1

TESTED LEAKAGE RATES AVAILABLE, CONTACT FAB-TECH INC.

Leakage Classification L/s/m² (ft³/min/ft²)

Pressure Class	Required Range		Extended Range (Optional)	
	0.25 kPa (1" wg)	1.0 kPa (4" wg)	2.0 kPa (8" wg)	3.0 kPa (12" wg)
1A	15.2 (3)*	N/A	N/A	N/A
1	20.3 (4)	40.6 (8)	55.9 (11)	71.1 (14)
2	50.8 (10)	102 (20)	142 (28)	178 (35)
3	203 (40)	406 (80)	569 (112)	711 (140)

*Units for maximum ratings in () are CFM Sq. Ft.

■ Damper Leakage Test based on ANSI/AMCA Standard 500-D-07, Ref. Fig 5.6

■ Pressure Drop Test based on AMCA Standard 500-D-98, Ref. Fig 5.3

NOTES:

1. ALL DUCT FITTINGS WITH STANDARD FAB-TECH CONNECTIONS INCLUDE GASKETS AND CLAMPS OR HARDWARE AS REQUIRED FOR INSTALLATION.

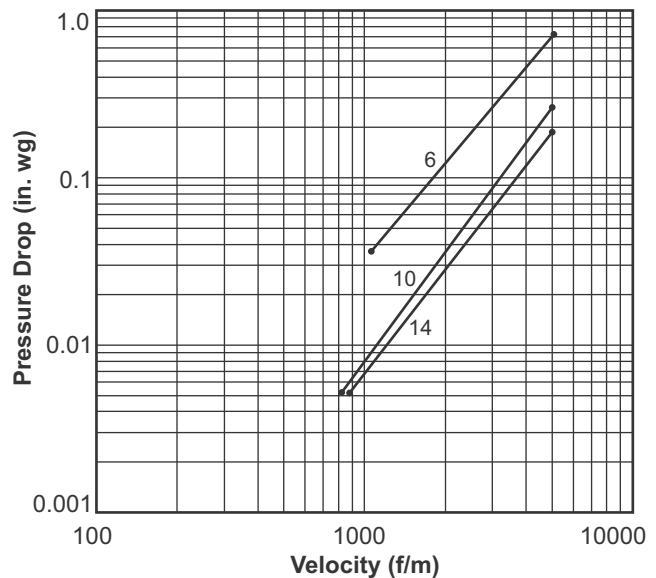
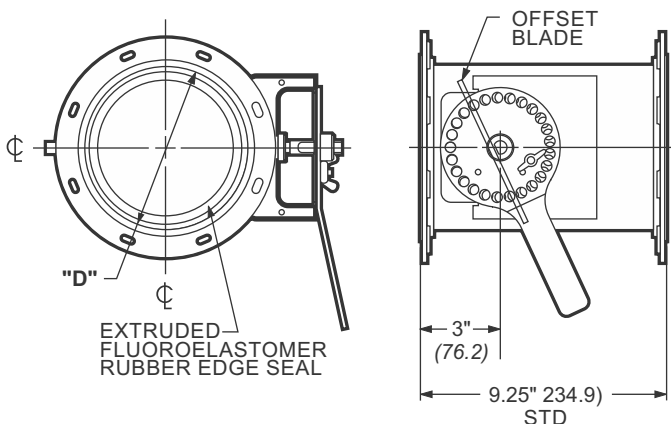

METRIC EQUIVALENTS ARE SHOWN IN PARENTHESIS & ITALICS (MILLIMETERS OR AS NOTED)

4" (101.6) -14" (355.6) Industrial Isolation Short Damper

SPECIFICATIONS

- BODY:** COATED 20GA (0.95) STAINLESS STEEL
- BODY LENGTH:** 4" (101.6) MIN WITH EZ FLANGES
4-1/2" (114.3) MIN WITH CAST OR FLAT RINGS
- OPTION:** CUSTOM LENGTH
- COATING:** PERMASHIELD FLUOROPOLYMER BARRIER COATING
- JOINING SYSTEM:** FLOATING CAST STAINLESS STEEL RINGS
- OPTION:** FLOATING STAINLESS STEEL FLAT RINGS 4" (101.6) - 14" (355.6)
- OPTION:** FLOATING BLACK IRON FLAT RINGS 4" (101.6) - 14" (355.6)
- OPTION:** EZ JOINING SYSTEM 4" (101.6) - 14" (355.6)
- OPTION:** CUSTOM HOLE PATTERN
- BLADE:** 4" (101.6) VIRGIN TEFLON
6" (152.4) -14" (355.6): 10GA (3.57) COATED STAINLESS STEEL
- EDGE SEAL:** FLUOROELASTOMER
- BLADE HOLDERS:** MOLDED PTFE
- AXLES:** DUAL SHAFT 1/2" (12.7) DIA. STAINLESS STEEL
- AXLE SEALS:** LIQUID TIGHT
- ACTUATOR:** MANUAL LEVER
- LOCKOUT:** 1/2° INTERVALS
- BLADE OPENS:** CCW
- OPEN/CLOSE TORQUE:** 250 in-lb (28.25 N-m) RECOMMENDED MIN

NOTES:

1. ALL DUCT FITTINGS WITH STANDARD FAB-TECH CONNECTIONS INCLUDE GASKETS AND CLAMPS OR HARDWARE AS REQUIRED FOR INSTALLATION.

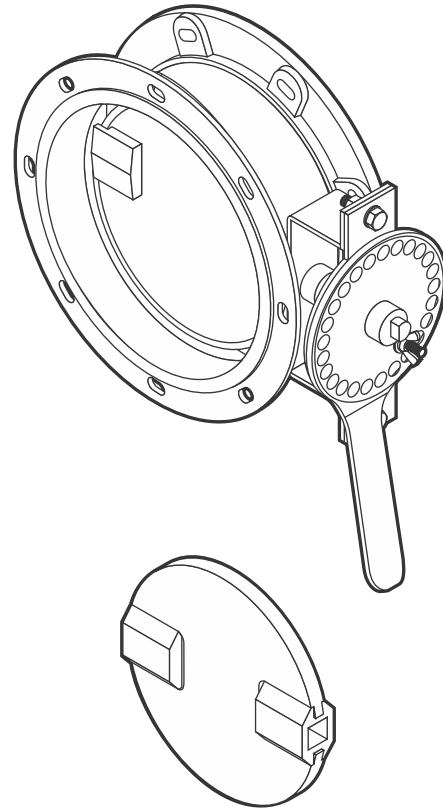

4" PTFE blade with molded PTFE blade holders

DIAMETER	BLADE	BODY
4" (101.6)	PTFE	20GA (0.95)
6" (152.4) TO 14" (355.6)	10GA (3.57)	20GA (0.95)

4" (101.6) MIN WITH EZ FLANGES
4-1/2" (114.3) MIN WITH CAST OR FLAT RINGS

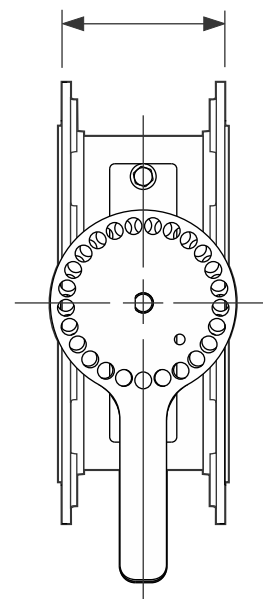
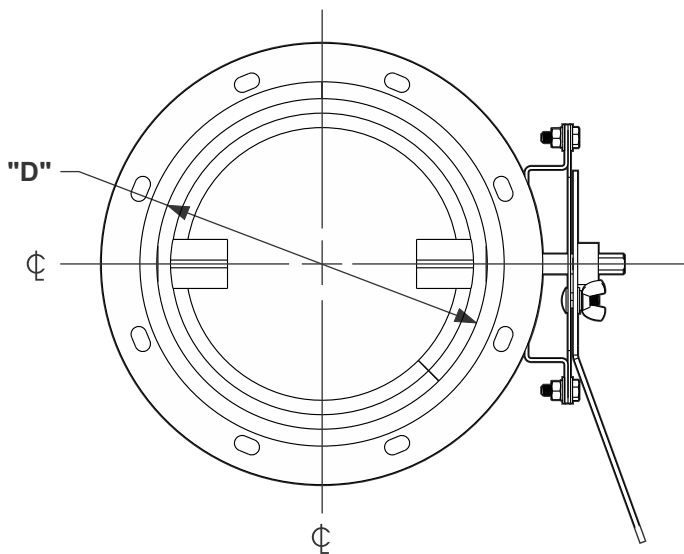

METRIC EQUIVALENTS ARE SHOWN IN PARENTHESIS & ITALICS (MILLIMETERS OR AS NOTED)

16" (406.4) - 34" (863.6) AMCA High Value Heavy Duty Industrial Damper

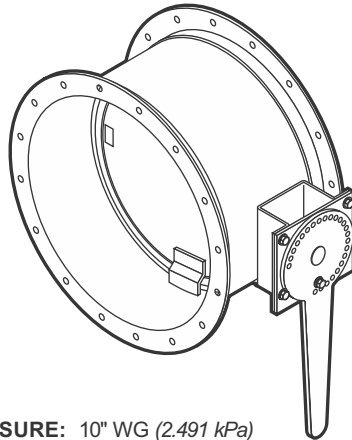

SPECIFICATIONS

DIFFERENTIAL PRESSURE: 10" WG (2.491 kPa)
BODY: COATED 12GA (3.57) STAINLESS STEEL
BODY LENGTH: 10" (254.0)
COATING: PERMASHIELD FLUOROPOLYMER BARRIER COATING
JOINING SYSTEM: STITCH WELDED COATED BLACK IRON VAN STONE RINGS

OPTION: CUSTOM HOLE PATTERN

MOUNTING HOLES: STRADDLE VERTICAL CENTERLINE

BLADE: OFFSET - 1/4" (6.35) COATED STAINLESS STEEL

BLADE EDGE SEAL: VITON

BLADE STOPS: WELDED

AXLES: DUAL SHAFT 1.38" (35.1) DIA. STAINLESS STEEL

AXLE SEALS: LIQUID TIGHT

SLEEVE BEARINGS: THERMOPLASTIC

ACTUATOR: MANUAL LEVER

OPTION: MANUAL GEAR BOX W/ LOCK OUT

OPTION: CUSTOM ACTUATOR MOUNTING KIT

OPTION: ELECTRIC ACTUATOR

OPTION: PNEUMATIC ACTUATOR

LOCKOUT: 1/2° INTERVALS

BLADE OPENS: CCW

NOTES:

- ALL DUCT FITTINGS WITH STANDARD FAB-TECH CONNECTIONS INCLUDE GASKETS AND CLAMPS OR HARDWARE AS REQUIRED FOR INSTALLATION.

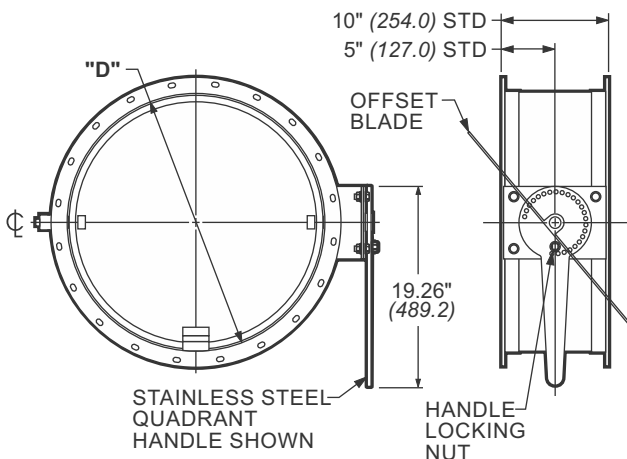

FAB-TECH, INC. CERTIFIES THAT THE INDUSTRIAL SINGLE BLADE ISOLATION DAMPER SHOWN HEREIN IS LICENSED TO BEAR THE AMCA SEAL. THE RATINGS SHOWN ARE BASED ON TESTS AND PROCEDURES PERFORMED IN ACCORDANCE WITH AMCA PUB 511 AND COMPLY W/ THE REQUIREMENTS OF THE AMCA CERTIFIED RATINGS PROGRAM.

THE AMCA CERTIFIED RATINGS SEAL APPLIES TO AIR LEAKAGE RATINGS AND AIR PERFORMANCE RATINGS.

- TEST METHOD PER AMCA STANDARD 500-89: DATA BASED ON A SEATING TORQUE OF: 764 in-lbf/ft² FOR 16" (406.4) DAMPER, 86 in-lbf/ft² FOR 48" (1219.2) DAMPER
- AIR LEAKAGE IS BASED ON OPERATION BETWEEN 50°F & 104°F (10°C TO 40°C) AND DATA CORRECTED TO REPRESENT STANDARD AIR DENSITY 0.075 lbs/ft³

Damper Dia.	Pressure	AMCA Leakage Class
16" - 34" (406.4 - 863.6)	1" WG	1A
	4", 8", 12" WG	1

TESTED LEAKAGE RATES AVAILABLE, CONTACT FAB-TECH INC.

Pressure Class	Leakage Classification L/s/m ² (ft ³ /min/ft ²)			
	Required Range	Extended Range (Optional)		
	0.25 kPa (1" wg)	1.0 kPa (4" wg)	2.0 kPa (8" wg)	3.0 kPa (12" wg)
1A	15.2 (3)*	N/A	N/A	N/A
1	20.3 (4)	40.6 (8)	55.9 (11)	71.1 (14)
2	50.8 (10)	102 (20)	142 (28)	178 (35)
3	203 (40)	406 (80)	569 (112)	711 (140)

*Units for maximum ratings in () are CFM Sq. Ft.

■ Damper Leakage Test based on ANSI/AMCA Standard 500-D-07, Ref. Fig 5.6

■ Pressure Drop Test based on AMCA Standard 500-D-98, Ref. Fig 5.3

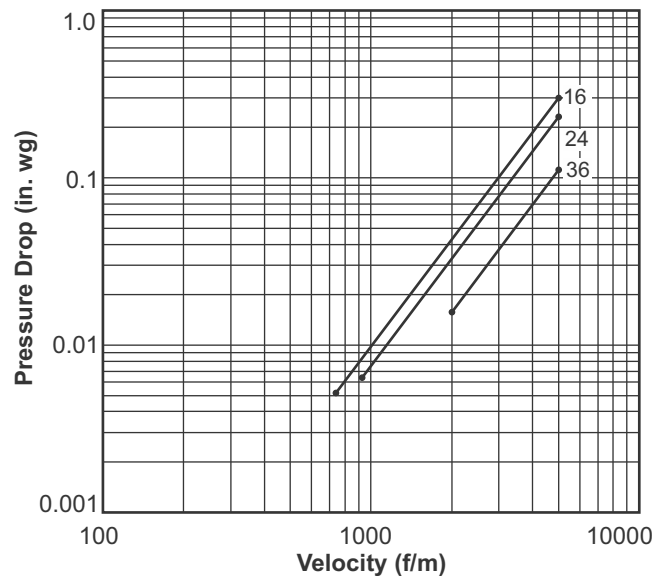

METRIC EQUIVALENTS ARE SHOWN IN PARENTHESIS & ITALICS (MILLIMETERS OR AS NOTED)

16" (406.4) - 48" (1219.2) High Value Heavy Duty Industrial Damper (HVD)

SPECIFICATIONS

- DIFFERENTIAL PRESSURE:** 10" WG (2.491 kPa)
- BODY:** COATED 12GA (2.78) STAINLESS STEEL
- BODY LENGTH:** 10" (254.0)
- COATING:** PERMASHIELD FLUOROPOLYMER BARRIER COATING
- JOINING SYSTEM:** FULLY WELDED STAINLESS STEEL VAN STONE RINGS
- OPTION:** CUSTOM HOLE PATTERN
- OPTION:** STITCH WELDED STAINLESS STEEL VAN STONE RINGS
- MOUNTING HOLES:** STRADDLE VERTICAL CENTERLINE
- BLADE:** 1/4" (6.35) COATED STAINLESS STEEL
- BLADE STOPS:** WELDED W/ VITON BLADE SEAL
- AXLES:** DUAL SHAFT 1.38 (35.1) DIA. STAINLESS STEEL
- AXLE SEALS:** LIQUID TIGHT
- SLEEVE BEARINGS:** THERMOPLASTIC
- ACTUATOR:** MANUAL LEVER
- OPTION:** MANUAL GEAR BOX W/ LOCK OUT
- OPTION:** CUSTOM ACTUATOR MOUNTING KIT
- OPTION:** ELECTRIC ACTUATOR
- OPTION:** PNEUMATIC ACTUATOR
- LOCKOUT:** 1/2° INTERVALS
- BLADE OPENS:** CCW
- OPEN/CLOSE TORQUE:** 1000 in-lb (112.98 N-m) RECOMMENDED MIN

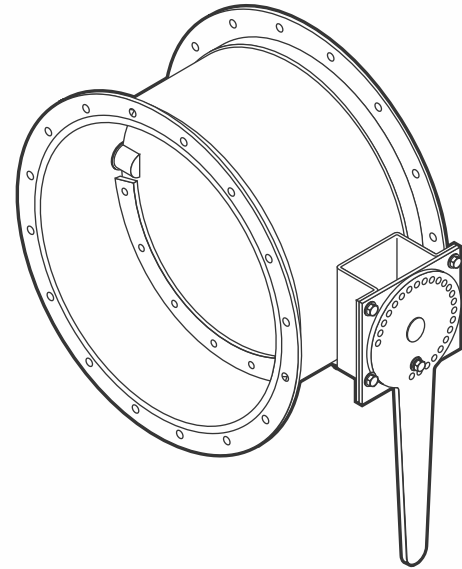

NOTES:

1. ALL DUCT FITTINGS WITH STANDARD FAB-TECH CONNECTIONS INCLUDE GASKETS AND CLAMPS OR HARDWARE AS REQUIRED FOR INSTALLATION.

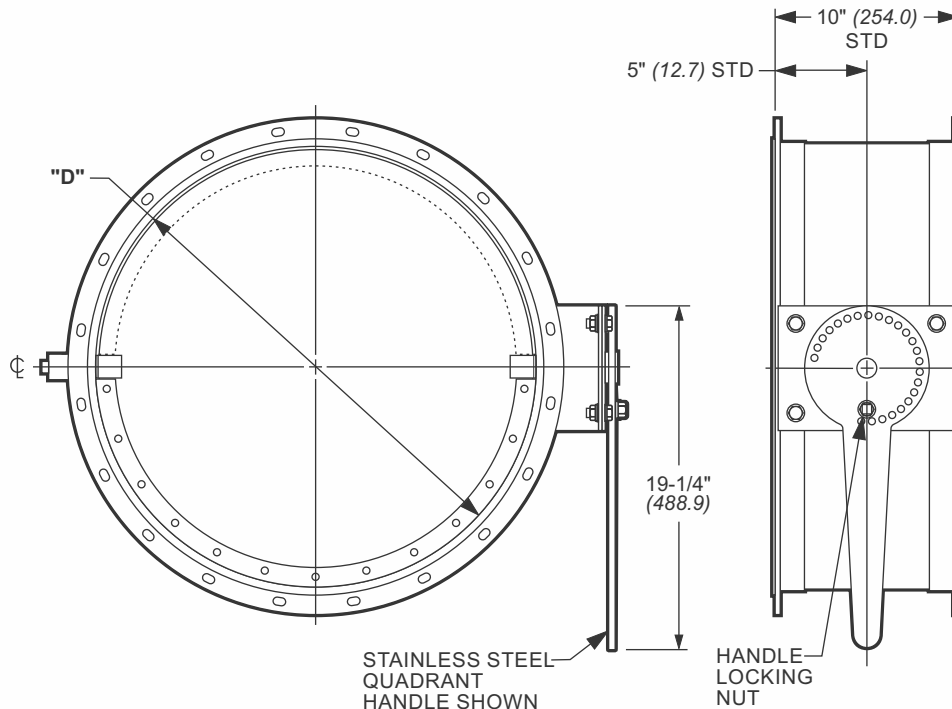

*SHOWN WITH MANUAL HANDLE ACTUATOR OPTION

METRIC EQUIVALENTS ARE SHOWN IN PARENTHESIS & ITALICS (MILLIMETERS OR AS NOTED)

36" (914.4) - 48" (1219.2) AMCA High Value Heavy Duty Industrial Damper

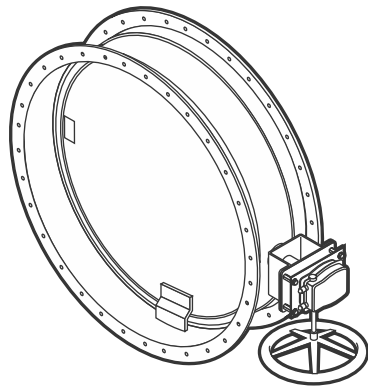

SPECIFICATIONS

DIFFERENTIAL PRESSURE: 10" WG (2.491 kPa)
BODY: COATED 12GA (2.78) STAINLESS STEEL
JOINING SYSTEM: STITCH WELDED COATED BLACK IRON VAN STONE RINGS

OPTION: CUSTOM HOLE PATTERN

MOUNTING HOLES: STRADDLE VERTICAL CENTERLINE
BODY LENGTH: 10" (254.0)
COATING: PERMASHIELD FLUOROPOLYMER BARRIER COATING
BLADE: OFFSET - 1/4" (6.35) COATED STAINLESS STEEL
BLADE EDGE SEAL: VITON
BLADE STOPS: WELDED
AXLES: DUAL SHAFT 1.38 (35.1) DIA. STAINLESS STEEL
AXLE SEALS: LIQUID TIGHT
SLEEVE BEARINGS: THERMOPLASTIC
ACTUATOR: MANUAL GEAR BOX W/ LOCK OUT
OPTION: CUSTOM ACTUATOR MOUNTING KIT
OPTION: ELECTRIC ACTUATOR
OPTION: PNEUMATIC ACTUATOR
LOCKOUT: 1/2° INTERVALS
BLADE OPENS: CCW

NOTES:

- ALL DUCT FITTINGS WITH STANDARD FAB-TECH CONNECTIONS INCLUDE GASKETS AND CLAMPS OR HARDWARE AS REQUIRED FOR INSTALLATION.

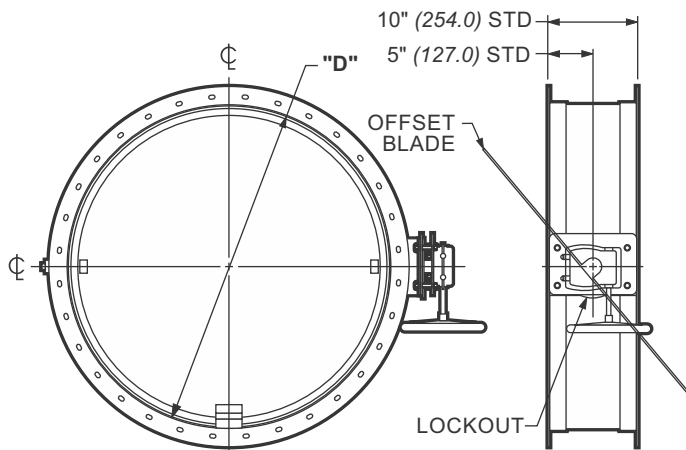

FAB-TECH, INC. CERTIFIES THAT THE INDUSTRIAL SINGLE BLADE ISOLATION DAMPER SHOWN HEREIN IS LICENSED TO BEAR THE AMCA SEAL. THE RATINGS SHOWN ARE BASED ON TESTS AND PROCEURES PERFORMED IN ACCORDANCE WITH AMCA PUB 511 AND COMPLY W/ THE REQUIREMENTS OF THE AMCA CERTIFIED RATINGS PROGRAM.

THE AMCA CERTIFIED RATINGS SEAL APPLIES TO AIR LEAKAGE RATINGS AND AIR PERFORMANCE RATINGS.

- TEST METHOD PER AMCA STANDARD 500-89: DATA BASED ON A SEATING TORQUE OF: 125 in-lbf/ft² FOR 16" (406.4) DAMPER, 86 in-lbf/ft² FOR 48" (1219.2) DAMPER
- AIR LEAKAGE IS BASED ON OPERATION BETWEEN 50°F & 104°F (10°C TO 40°C) AND DATA CORRECTED TO REPRESENT STANDARD AIR DENSITY 0.075 lbs/ft³

Damper Dia.	Pressure	AMCA Leakage Class
36" - 48" (914.4 - 1219.2)	1" WG	1A
	4", 8", 12" WG	1

TESTED LEAKAGE RATES AVAILABLE, CONTACT FAB-TECH INC.

Pressure Class	Leakage Classification		L/s/m ² (ft ³ /min/ft ²)	
	Required Range	Extended Range (Optional)		
	0.25 kPa (1" wg)	1.0 kPa (4" wg)	2.0 kPa (8" wg)	3.0 kPa (12" wg)
1A	15.2 (3)*	N/A	N/A	N/A
1	20.3 (4)	40.6 (8)	55.9 (11)	71.1 (14)
2	50.8 (10)	102 (20)	142 (28)	178 (35)
3	203 (40)	406 (80)	569 (112)	711 (140)

*Units for maximum ratings in () are CFM Sq. Ft.

- Damper Leakage Test based on ANSI/AMCA Standard 500-D-07, Ref. Fig 5.6
- Pressure Drop Test based on AMCA Standard 500-D-98, Ref. Fig 5.3

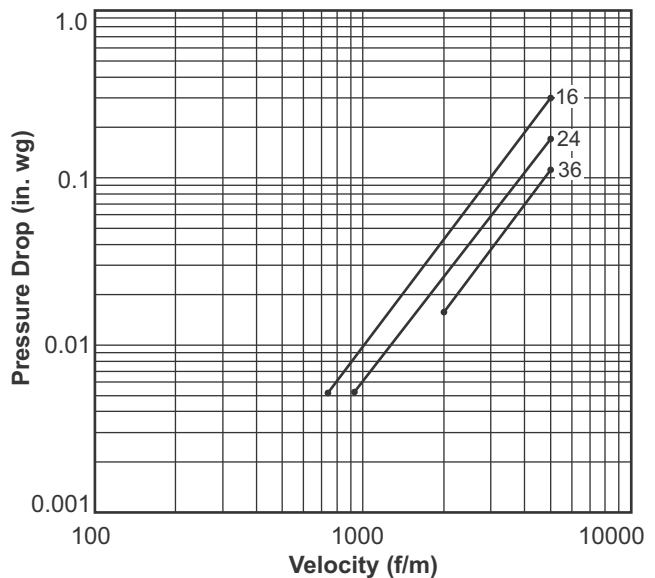

METRIC EQUIVALENTS ARE SHOWN IN PARENTHESIS & ITALICS (MILLIMETERS OR AS NOTED)

50" (1270.0) & Larger Reinforced Heavy Duty Industrial Damper

SPECIFICATIONS

- DIFFERENTIAL PRESSURE:** 10" WG (2.491 kPa)
- BODY:** COATED 1/4" (6.35) STAINLESS STEEL
 - OPTION:** AVAIL TO 120" (3048.0) DIA. W/ ENGINEERING REVIEW
- JOINING SYSTEM:** FULLY WELDED STAINLESS STEEL VAN STONE RINGS
 - OPTION:** CUSTOM HOLE PATTERN
- MOUNTING HOLES:** STRADDLE VERTICAL CENTERLINE
- BODY LENGTH:** 10" (254.0)
- COATING:** PERMASHIELD FLUOROPOLYMER BARRIER COATING
- BLADE:** 3/8" (9.53) COATED REINFORCED STAINLESS STEEL
- BLADE STOPS:** WELDED
- AXLES:** DUAL SHAFT 1.85 (47.0) DIA. STAINLESS STEEL
- AXLE SEALS:** LIQUID TIGHT
- SLEEVE BEARINGS:** THERMOPLASTIC
- ACTUATOR:** GEAR ACTUATOR W/ LOCK OUT
 - OPTION:** CUSTOM ACTUATOR MOUNTING KIT
 - OPTION:** ELECTRIC ACTUATOR
 - OPTION:** PNEUMATIC ACTUATOR

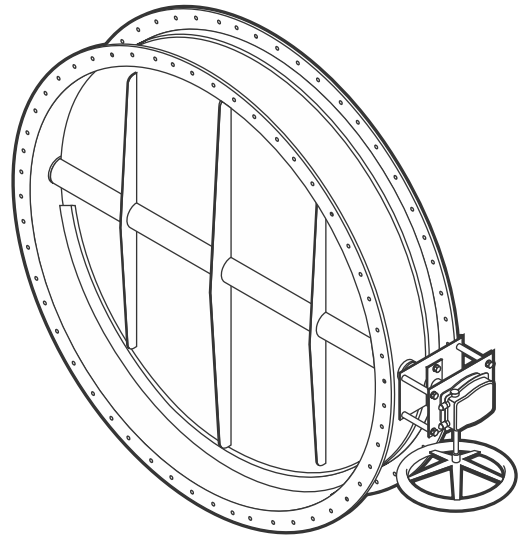

**PNEUMATIC ACTUATED DAMPERS
HYTORK ACTUATOR STANDARD**

- XL45 - UP TO 20" (508.0)
- XL280 - 21" (533.4) TO 48" (1219.2)
- XL425 - 49" (1244.6) TO 94" (2387.6)

- LOCKOUT:** 1/2° INTERVALS
- BLADE OPENS:** CCW
- OPEN/CLOSE TORQUE:** 1600 in-lb (180.78 N-m) RECOMMENDED MIN

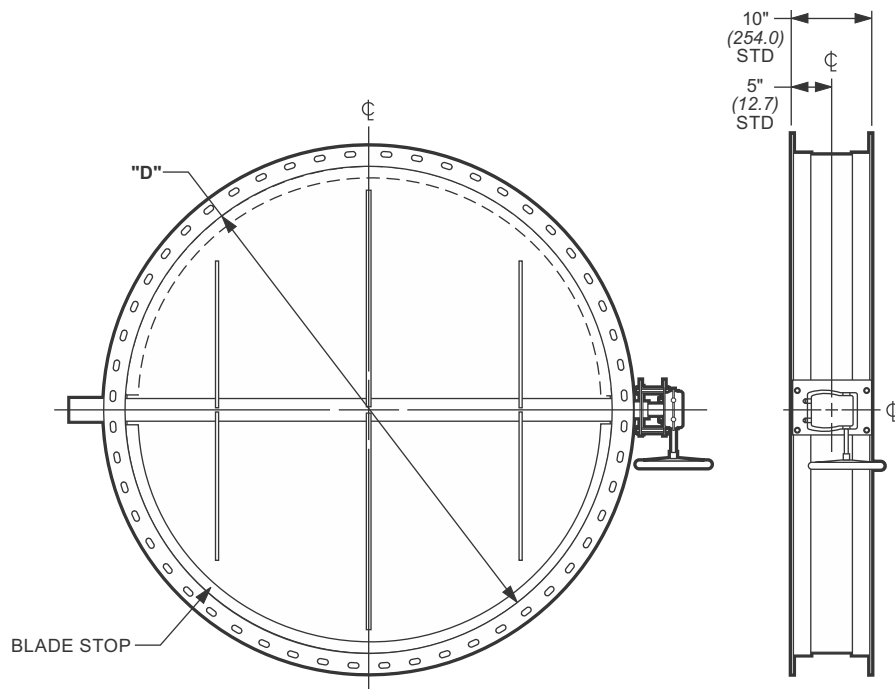

NOTES:

ALL DUCT FITTINGS WITH STANDARD FAB-TECH CONNECTIONS INCLUDE GASKETS AND CLAMPS OR HARDWARE AS REQUIRED FOR INSTALLATION.

METRIC EQUIVALENTS ARE SHOWN IN PARENTHESIS & ITALICS (MILLIMETERS OR AS NOTED)

24" (609.6) - 84" (2133.6) Ultra Series Industrial Damper

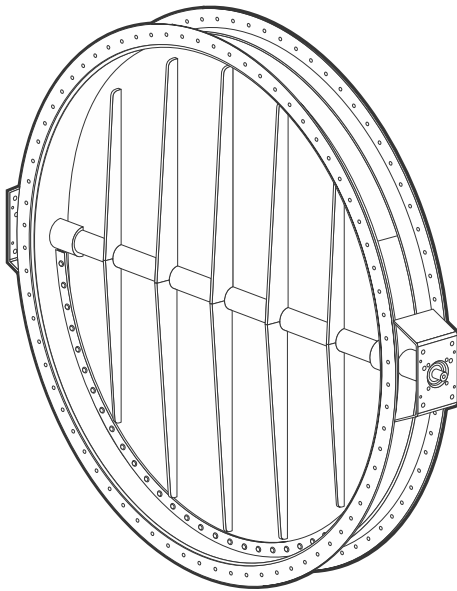

SPECIFICATIONS

DIFFERENTIAL PRESSURE: 30" WG (7.473 kPa)

BODY: COATED 24" (609.6) - 44" (1117.6) DIA. 10GA (3.57) STAINLESS STEEL
 COATED 46" (1168.4) - 84" (2133.6) DIA. 1/4" (6.35) STAINLESS STEEL

OPTION: AVAIL TO 120" (3048.0) DIA. W/ ENGINEERING REVIEW

JOINING SYSTEM: FULLY WELDED STAINLESS STEEL VAN STONE RINGS

OPTION: CUSTOM HOLE PATTERN

MOUNTING HOLES: STRADDLE VERTICAL CENTERLINE

BODY LENGTH: 10" (254.0)

COATING: PERMASHIELD FLUOROPOLYMER BARRIER COATING

BLADE: COATED REINFORCED
 24" (609.6) - 58" (1473.2) DIA. 1/4" (6.35) STAINLESS STEEL
 60" (1524.0) - 84" (2133.6) DIA. 3/8" (9.53) STAINLESS STEEL

BLADE STOPS: WELDED

AXLES: 24" (609.6) - 44" (1117.6) DIA. DUAL SHAFT 1.20 (30.5) DIA. STAINLESS STEEL
 46" (1168.4) - 58" (1473.2) DIA. DUAL SHAFT 1.85 (47.0) DIA. STAINLESS STEEL
 60" (1524.0) & UP DUAL SHAFT 2.45 (62.2) DIA. STAINLESS STEEL

AXLE SEALS: LIQUID TIGHT

SLEEVE BEARINGS: BRONZE SLEEVE [24" (609.6) - 58" (1473.2)]
 SPHERICAL HEIM [60" (1524.0) - 84" (2133.6)]

ACTUATOR: NONE, STANDARD INTERFACE FOR ROTORK HIGH SPEED SI-1 SERIES

OPTION: CUSTOM ACTUATOR MOUNTING KIT

OPTION: ELECTRIC ACTUATOR

OPTION: PNEUMATIC ACTUATOR

LOCKOUT: VARIABLE POSITION

BLADE POSITION INDICATOR: IDLE SIDE

BLADE OPENS: CCW

NOTES:

1. ALL DUCT FITTINGS WITH STANDARD FAB-TECH CONNECTIONS INCLUDE GASKETS AND CLAMPS OR HARDWARE AS REQUIRED FOR INSTALLATION.

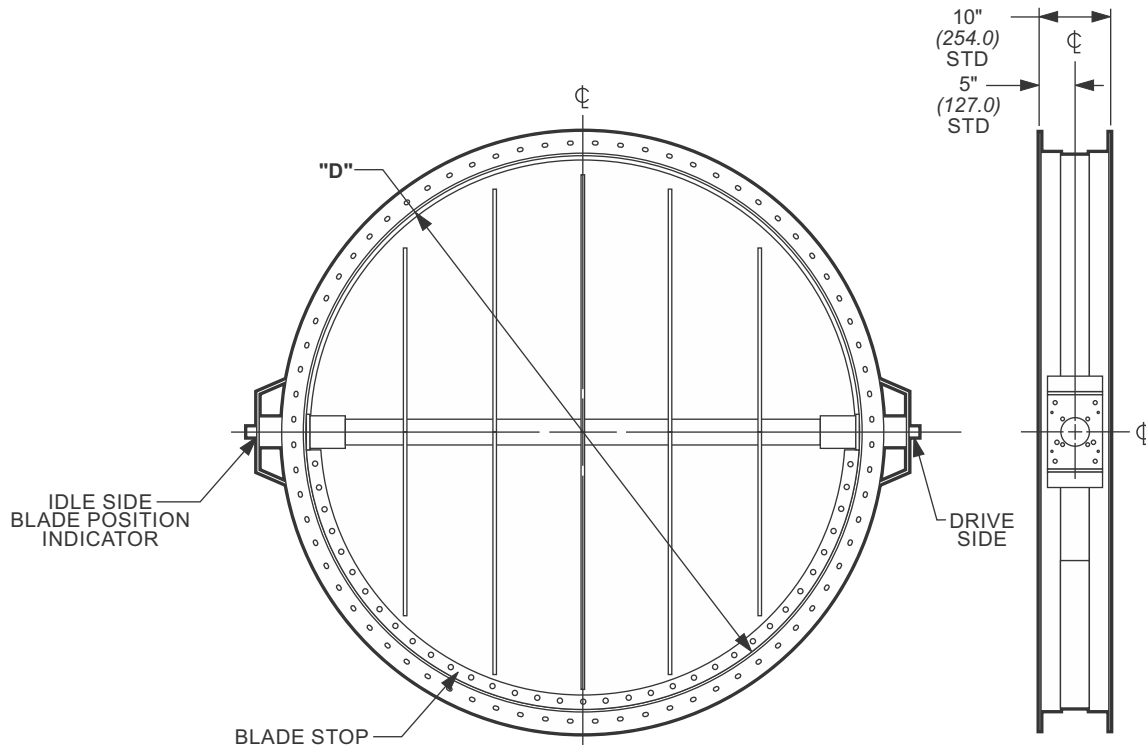

METRIC EQUIVALENTS ARE SHOWN IN PARENTHESIS & ITALICS (MILLIMETERS OR AS NOTED)

86" (2184.4) - 120" (3048.0) Ultra Series Industrial Damper

SPECIFICATIONS

- DIFFERENTIAL PRESSURE:** 30" WG (7.473 kPa)
- BODY:** 1/4" (6.35) STAINLESS STEEL
- JOINING SYSTEM:** FULLY WELDED STAINLESS STEEL VAN STONE RINGS
- OPTION:** CUSTOM HOLE PATTERN
- MOUNTING HOLES:** STRADDLE VERTICAL CENTERLINE
- BODY LENGTH:** 14.5" (368.3)
- COATING:** PERMASHIELD FLUOROPOLYMER BARRIER COATING
- BLADES:** COATED REINFORCED
3/8" (9.53) STAINLESS STEEL
- BLADE STOPS:** WELDED
- AXLES:** DUAL SHAFT 2.00 (50.8) DIA. STAINLESS STEEL
- AXLE SEALS:** LIQUID TIGHT
- BEARINGS:** SPHERICAL HEIM
- ACTUATOR:** NONE, F14 / FA14 MOUNTING PATTERN
- OPTION:** CUSTOM ACTUATOR MOUNTING KIT
- LOCKOUT:** VARIABLE POSITION
- BLADE POSITION INDICATOR:** IDLE SIDE
- BLADE OPENS:** CW (TOP) - CCW (BOTTOM)

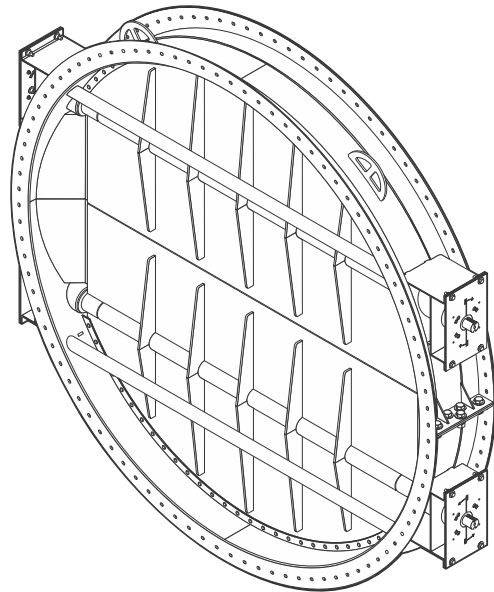

NOTES:

1. ALL DUCT FITTINGS WITH STANDARD FAB-TECH CONNECTIONS INCLUDE GASKETS AND CLAMPS OR HARDWARE AS REQUIRED FOR INSTALLATION.

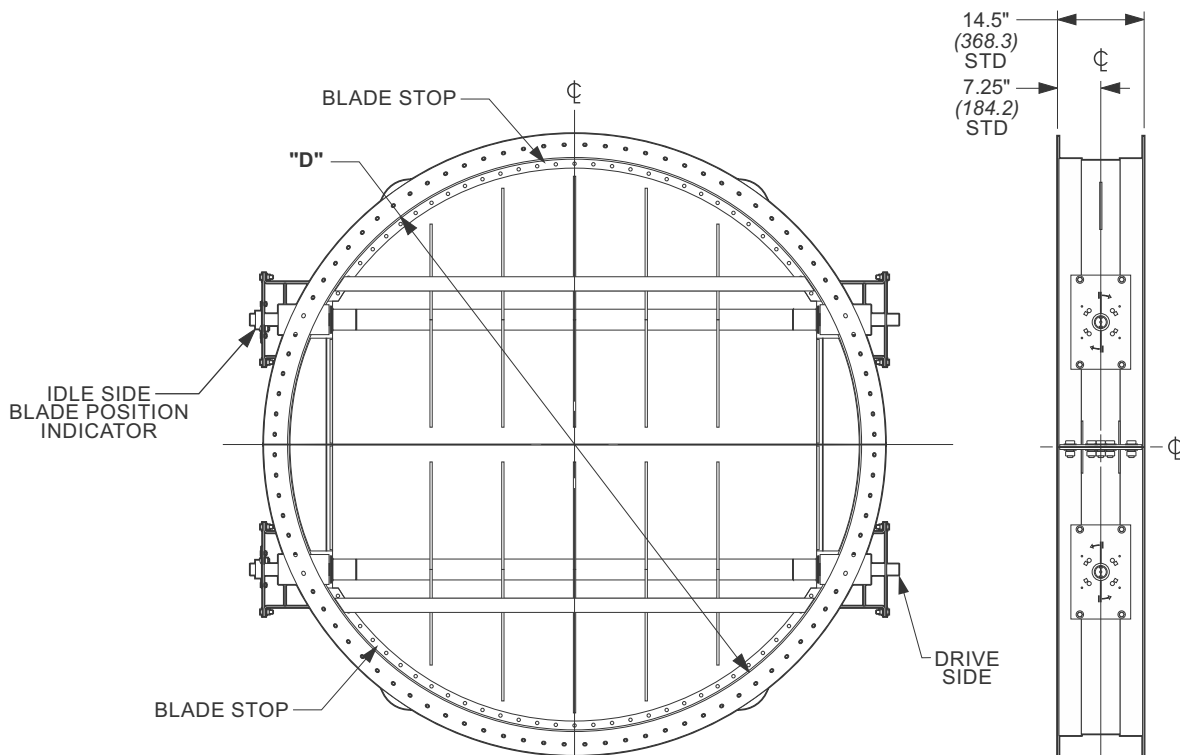

METRIC EQUIVALENTS ARE SHOWN IN PARENTHESIS & ITALICS (MILLIMETERS OR AS NOTED)

2" (50.8) & 3" (76.2) EZ Blastgate

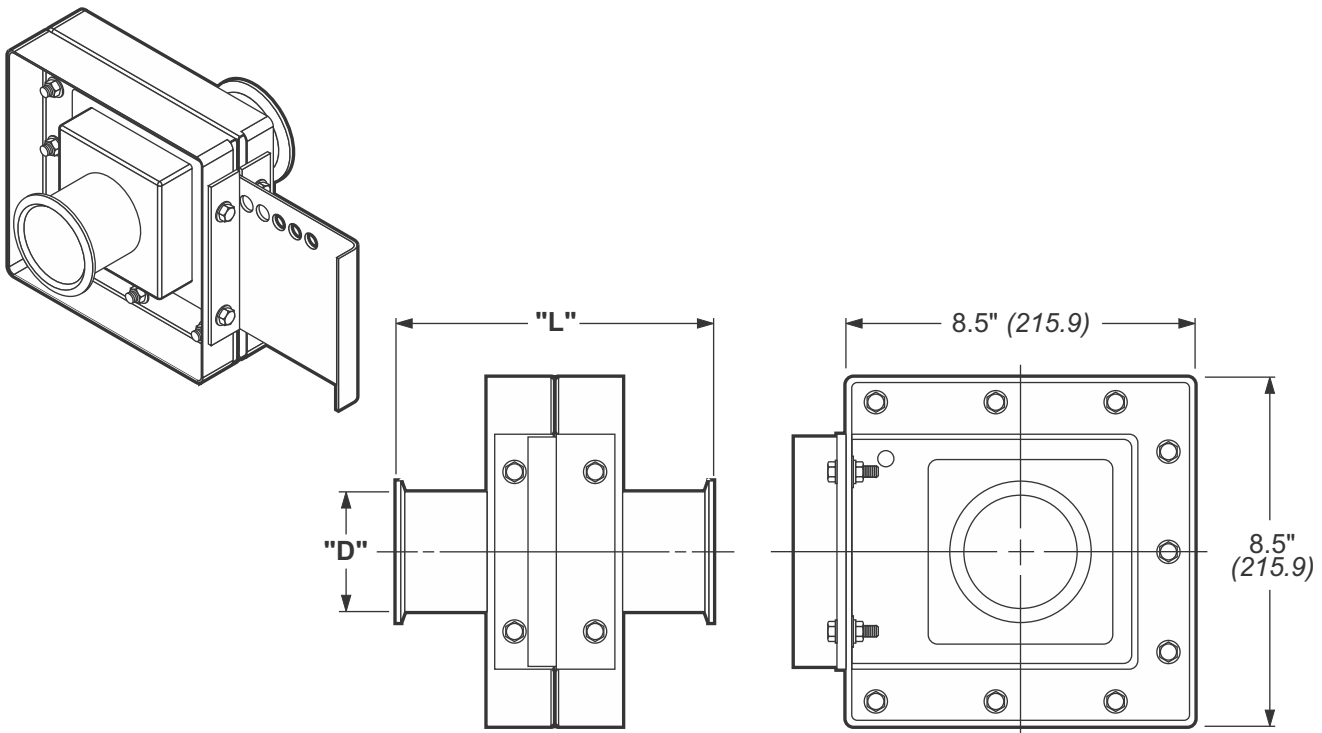

PART NO.*	DESCRIPTION	"D"	"L"
PZB02H	2" EZ-BLASTGATE HORIZONTAL	2" (50.8)	8.000" (203.2)
PZB03H	3" EZ-BLASTGATE HORIZONTAL	3" (76.2)	8.000" (203.2)

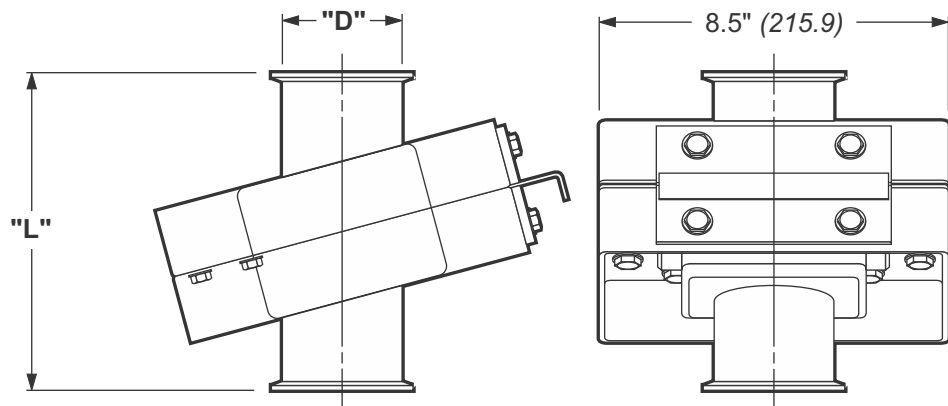

PART NO.*	DESCRIPTION	"D"	"L"
PZB02V	2" EZ-BLASTGATE VERTICAL	2" (50.8)	8.000" (203.2)
PZB03V	3" EZ-BLASTGATE VERTICAL	3" (76.2)	8.000" (203.2)

NOTES:

1. STAINLESS STEEL FRAME MATERIAL.
2. BLADE LOCKOUT SYSTEM

ALL SUBJECT FITTINGS WITH STANDARD FAB-TECH CONNECTIONS INCLUDE GASKETS AND CLAMPS OR HARDWARE AS REQUIRED FOR INSTALLATION.

METRIC EQUIVALENTS ARE SHOWN IN PARENTHESIS & ITALICS (MILLIMETERS OR AS NOTED)

4" (101.6) -36" (914.4) Horizontal Run Isolation Blastgate

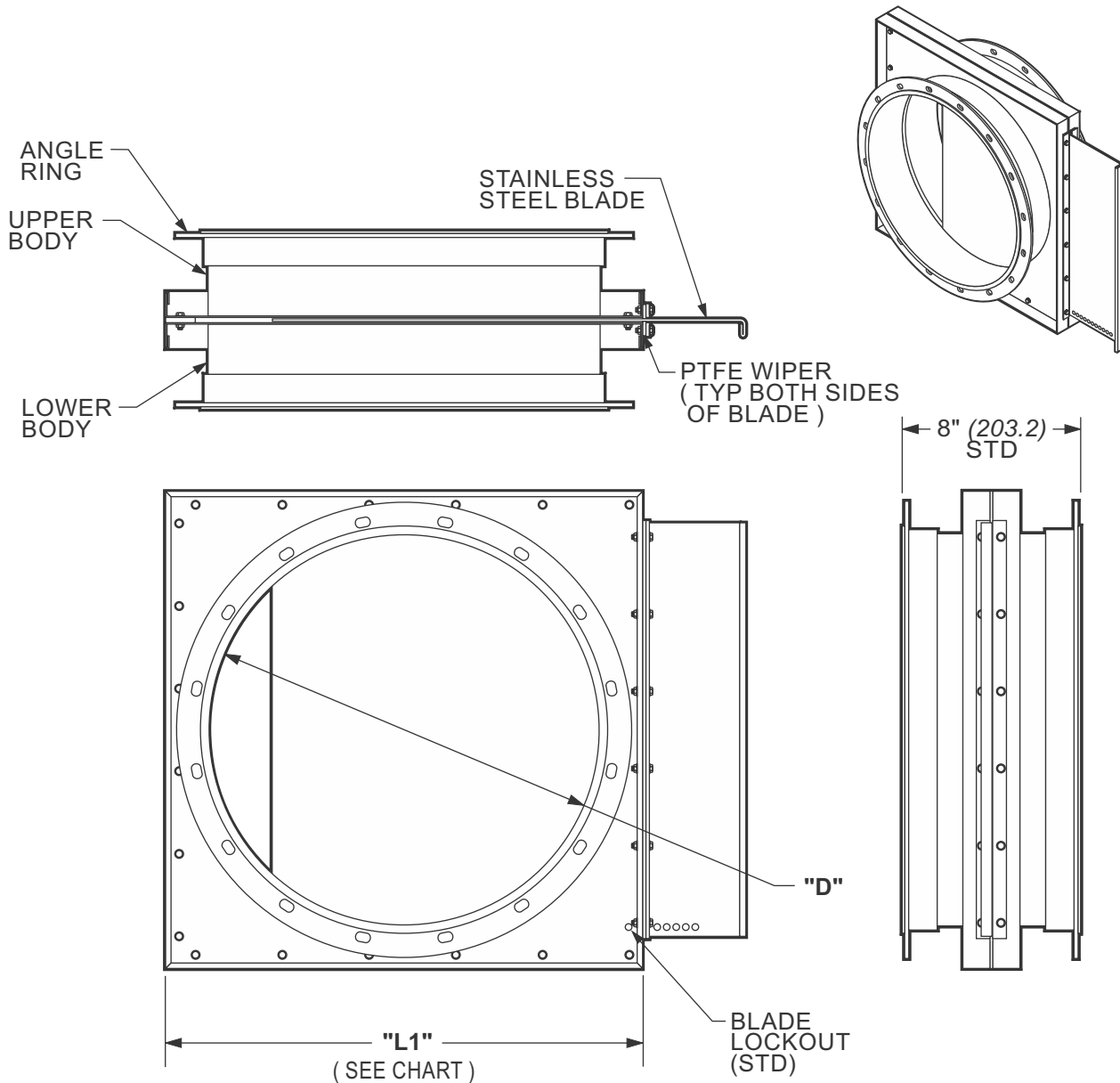

DUCT DIA. "D"	OUTSIDE DIM "L1"	BODY	BLADE	BODY BOLTS	NO. OF BLADES
4" (101.6) TO 16" (406.4)	DIA. "D" + 4" (101.6)	18GA (1.27)	18GA (1.27)	.31" (7.87)	1
18" (457.2) TO 36" (914.4)	DIA. "D" + 4.5" (114.3)	16GA (1.59)	16GA (1.59)	.31" (7.87)	1

NOTES:

1. STAINLESS STEEL FRAME MATERIAL.
2. BLADE LOCKOUT SYSTEM.
6. ALL DUCT FITTINGS WITH STANDARD FAB-TECH CONNECTIONS INCLUDE GASKETS AND CLAMPS OR HARDWARE AS REQUIRED FOR INSTALLATION.

DUCT JOINT / RING TYPE

- EZ** EZ CLAMP
4"Ø-14"Ø (101.6 - 355.6)
- SC** STAINLESS CAST RING
4"Ø-14"Ø (101.6 - 355.6)
- BI** BLACK IRON ANGLE RING
4"Ø-120"Ø (101.6 - 3048.0)
- SS** STAINLESS ANGLE RING
16"Ø-120"Ø (406.4 - 3048.0)

METRIC EQUIVALENTS ARE SHOWN IN PARENTHESIS & ITALICS (MILLIMETERS OR AS NOTED)

16" (406.4) - 36" (914.4) Horizontal Run Actuated Isolation Blastgate

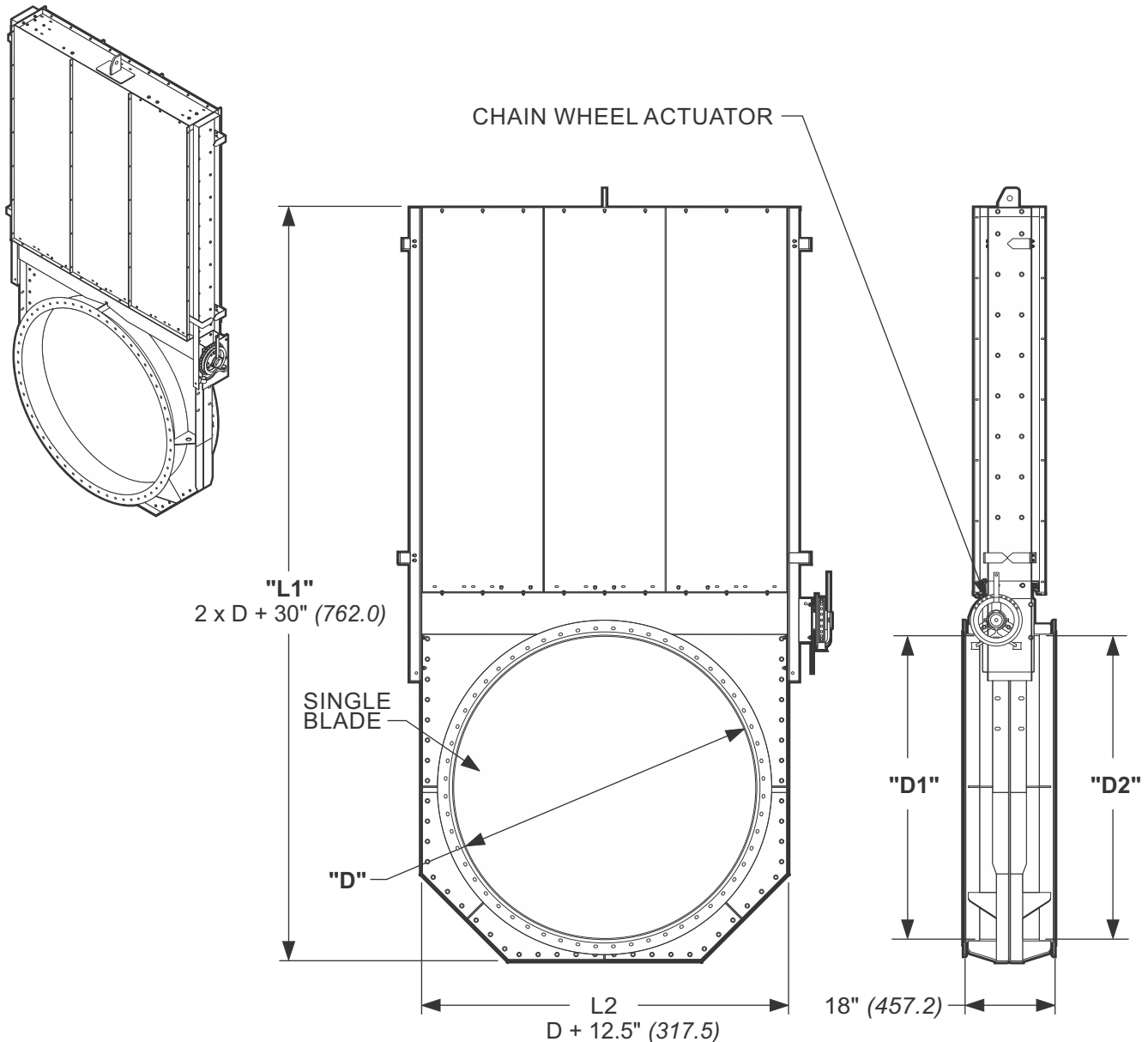

DUCT DIA. "D"	OUTSIDE DIM "L1"	BODY	BLADE	FRAME BOLTS	NO. OF BLADES
16" (406.4) TO 36" (914.4)	2 x D + 30" (762.0)	10GA (3.57)	12GA (2.78)	.38" (9.65)	1

NOTES:

1. STAINLESS STEEL BODY, RINGS AND BLADE.
2. BLADE LOCKOUT SYSTEM.
3. EXTERIOR POSITION INDICATOR.
4. **1** **OPTION:** BELLOWS ENCLOSED LEAD SCREW FOR ADDITIONAL CORROSION RESISTANCE (ADDS TO L1 LENGTH)
5. ALL DUCT FITTINGS WITH STANDARD FAB-TECH CONNECTIONS INCLUDE GASKETS AND CLAMPS OR HARDWARE AS REQUIRED FOR INSTALLATION.

DUCT JOINT / RING TYPE

- BI** BLACK IRON ANGLE RING
4"Ø-120"Ø (101.6 - 3048.0)
- SS** STAINLESS ANGLE RING
16"Ø-120"Ø (406.4 - 3048.0)

METRIC EQUIVALENTS ARE SHOWN IN PARENTHESIS & ITALICS (MILLIMETERS OR AS NOTED)

38" (965.2) & Larger Horizontal Run Isolation Blastgate

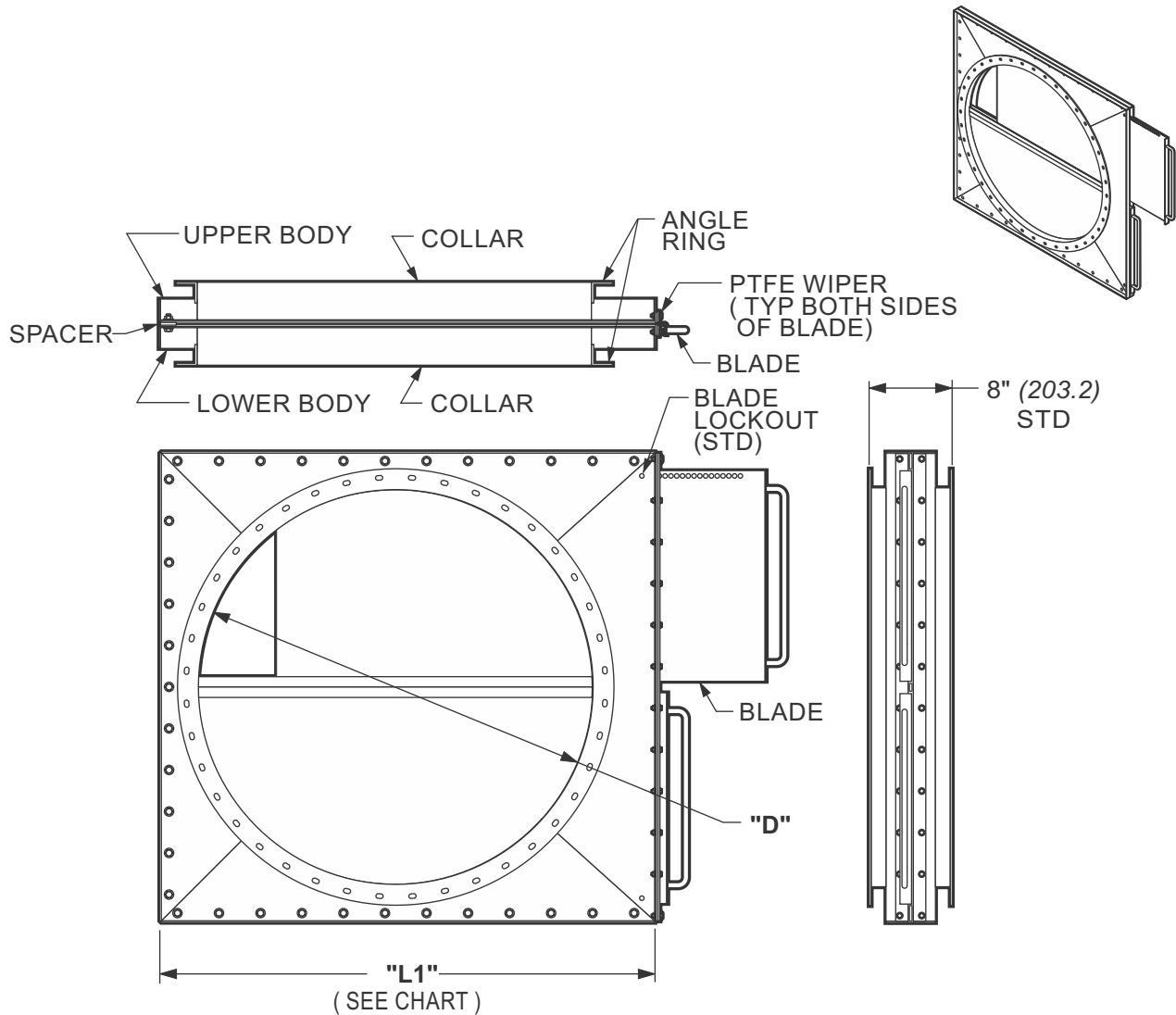

DUCT DIA. "D"	OUTSIDE DIM "L1"	BODY	BLADE	COLLAR	BODY BOLTS	NO. OF BLADES
38" (965.2) TO 46" (1168.4)	DIA. "D" + 10" (254.0)	10GA(3.57)	14GA(2.78)	14GA(2.78)	.31" (7.87)	2
48" (1219.2) TO 60" (1524.0)	DIA. "D" + 11" (279.4)	10GA(3.57)	12GA(1.98)	14GA(2.78)	.38" (9.65)	2
62" (1574.8) TO 84" (2133.6)	DIA. "D" + 11" (279.4)	10GA(3.57)	12GA(1.98)	14GA(2.78)	.38" (9.65)	3
*86" (2184.4) TO 96" (2438.4)	DIA. "D" + 11" (279.4)	10GA(3.57)	10GA(3.57)	12GA(1.98)	.50" (12.7)	3
*98" (2489.2) and UP	DIA. "D" + 11" (279.4)	3/16(4.76)	10GA(3.57)	10GA(3.57)	.63" (16.0)	4

* Blastgates 86" (2184.4) diameter and larger subject to engineering review and approval.

NOTES:

1. STAINLESS STEEL BODY, RINGS AND BLADE.
2. BLADE LOCKOUT SYSTEM.
3. BLASTGATES GREATER THAN 86" DIA. (2184.4mm) REQUIRES FAB-TECH ENGINEERING REVIEW AND APPROVAL.
4. ALL DUCT FITTINGS WITH STANDARD FAB-TECH CONNECTIONS INCLUDE GASKETS AND CLAMPS OR HARDWARE AS REQUIRED FOR INSTALLATION.

DUCT JOINT / RING TYPE

- BI** BLACK IRON ANGLE RING
4"Ø-120"Ø (101.6 - 3048.0)
- SS** STAINLESS ANGLE RING
16"Ø-120"Ø (406.4 - 3048.0)

METRIC EQUIVALENTS ARE SHOWN IN PARENTHESIS & ITALICS (MILLIMETERS OR AS NOTED)

38" (965.2) & Larger Horizontal Run Actuated Isolation Blastgate

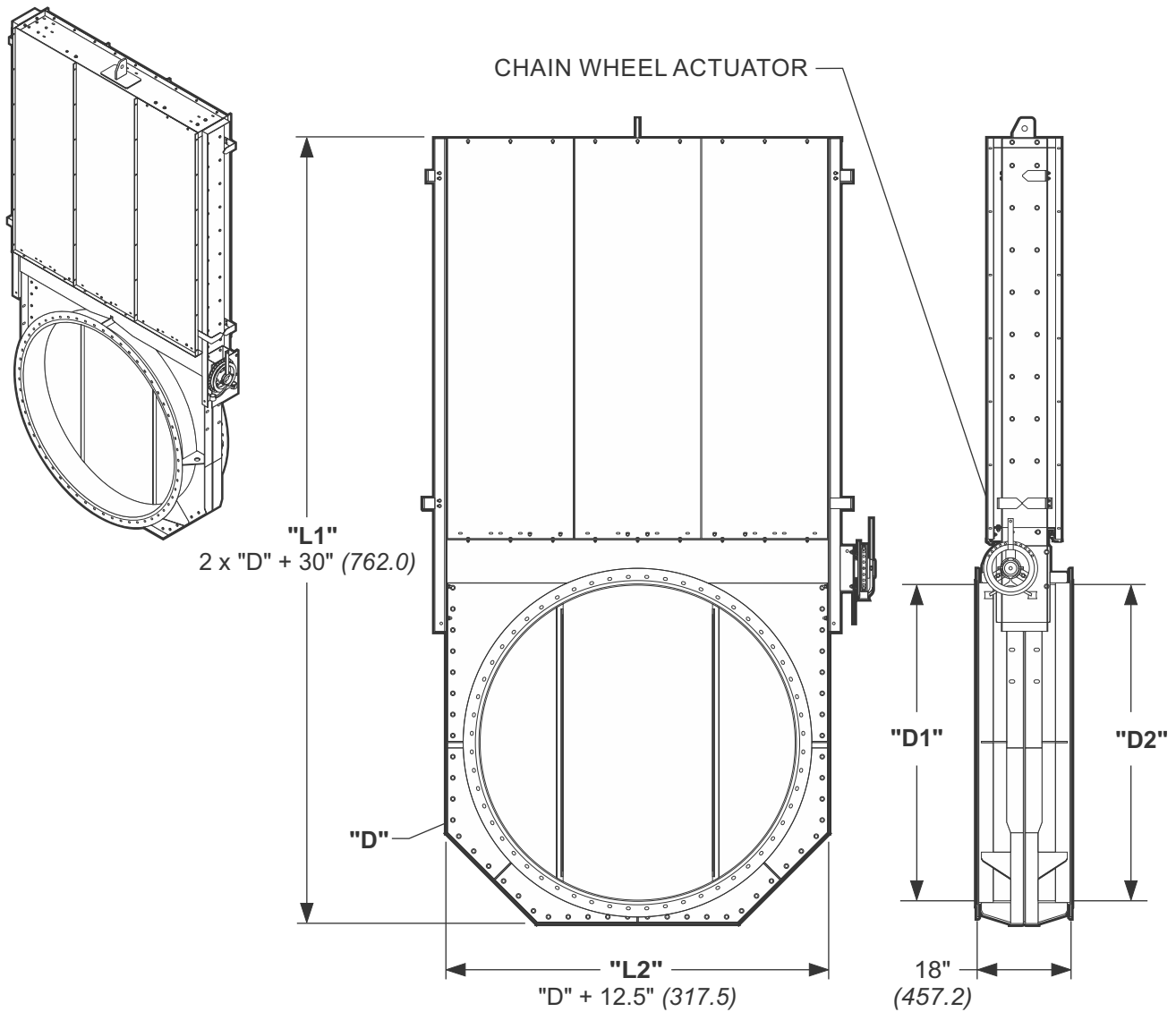

DUCT DIA. "D"	OUTSIDE DIM "L1"	BODY	BLADE	FRAME BOLTS	NO. OF BLADES
38" (965.2) TO 64" (1625.6)	2 x D + 30" (762.0)	10GA (3.57)	12GA (2.78)	.38" (9.65)	1
66" (1676.4) TO 88" (2235.2)	2 x D + 30" (762.0)	10GA (3.57)	12GA (2.78)	.43" (10.92)	1

NOTES:

1. STAINLESS STEEL BODY, RINGS AND BLADE.
2. BLADE LOCKOUT SYSTEM.
3. EXTERIOR POSITION INDICATOR.
4. **1** **OPTION:** BELLOWS ENCLOSED LEAD SCREW FOR ADDITIONAL CORROSION RESISTANCE (ADDS TO 11 LENGTH)
5. BLASTGATES 90" (2286.0) DIAMETER AND LARGER SUBJECT TO ENGINEERING REVIEW AND APPROVAL.
6. ALL DUCT FITTINGS WITH STANDARD FAB-TECH CONNECTIONS INCLUDE GASKETS AND CLAMPS OR HARDWARE AS REQUIRED FOR INSTALLATION.

DUCT JOINT / RING TYPE

- BI** BLACK IRON ANGLE RING
4"Ø-120"Ø (101.6 - 3048.0)
- SS** STAINLESS ANGLE RING
16"Ø-120"Ø (406.4 - 3048.0)

METRIC EQUIVALENTS ARE SHOWN IN PARENTHESIS & ITALICS (MILLIMETERS OR AS NOTED)

4" (101.6) - 36" (914.4) Vertical Run Isolation Blastgate

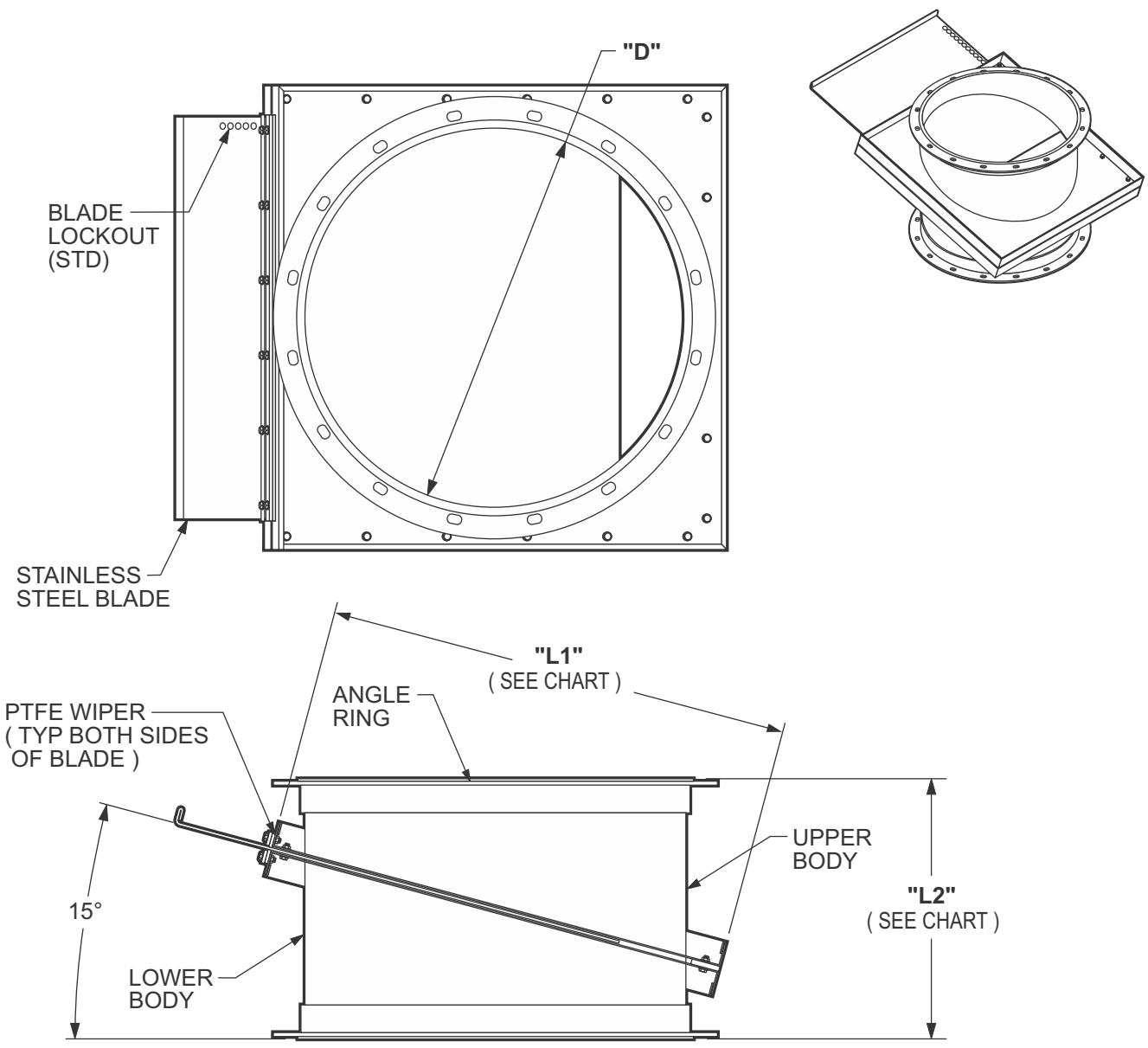

DUCT DIA. "D"	OUTSIDE DIM "L1"	BODY	BLADE	FRAME BOLTS	NO. OF BLADES	BLADE ANGLE	LENGTH "L2"
4" (101.6) TO 8" (203.2)	DIA. "D" + 4" (101.6)	18GA(1.27)	18GA(1.27)	.31"(7.87)	1	15°	8" (203.2)
10" (254.0) TO 16" (406.4)	DIA. "D" + 4" (101.6)	18GA(1.27)	18GA(1.27)	.31"(7.87)	1	15°	12" (304.8)
18" (457.2) TO 36" (914.4)	DIA. "D" + 4.5" (114.3)	16GA(1.59)	16GA(1.59)	.31"(7.87)	1	15°	16" (406.4)

NOTES:

1. STAINLESS STEEL BODY, RINGS AND BLADE.
2. BLADE LOCKOUT SYSTEM.
3. ALL DUCT FITTINGS WITH STANDARD FAB-TECH CONNECTIONS INCLUDE GASKETS AND CLAMPS OR HARDWARE AS REQUIRED FOR INSTALLATION.

DUCT JOINT / RING TYPE

- EZ** EZ CLAMP
4"Ø-14"Ø (101.6 - 355.6)
- SC** STAINLESS CAST RING
4"Ø-14"Ø (101.6 - 355.6)
- BI** BLACK IRON ANGLE RING
4"Ø-120"Ø (101.6 - 3048.0)
- SS** STAINLESS ANGLE RING
16"Ø-120"Ø (406.4 - 3048.0)

METRIC EQUIVALENTS ARE SHOWN IN PARENTHESIS & ITALICS (MILLIMETERS OR AS NOTED)

16" (406.4) -36" (914.4) Vertical Run Actuated Isolation Blastgate

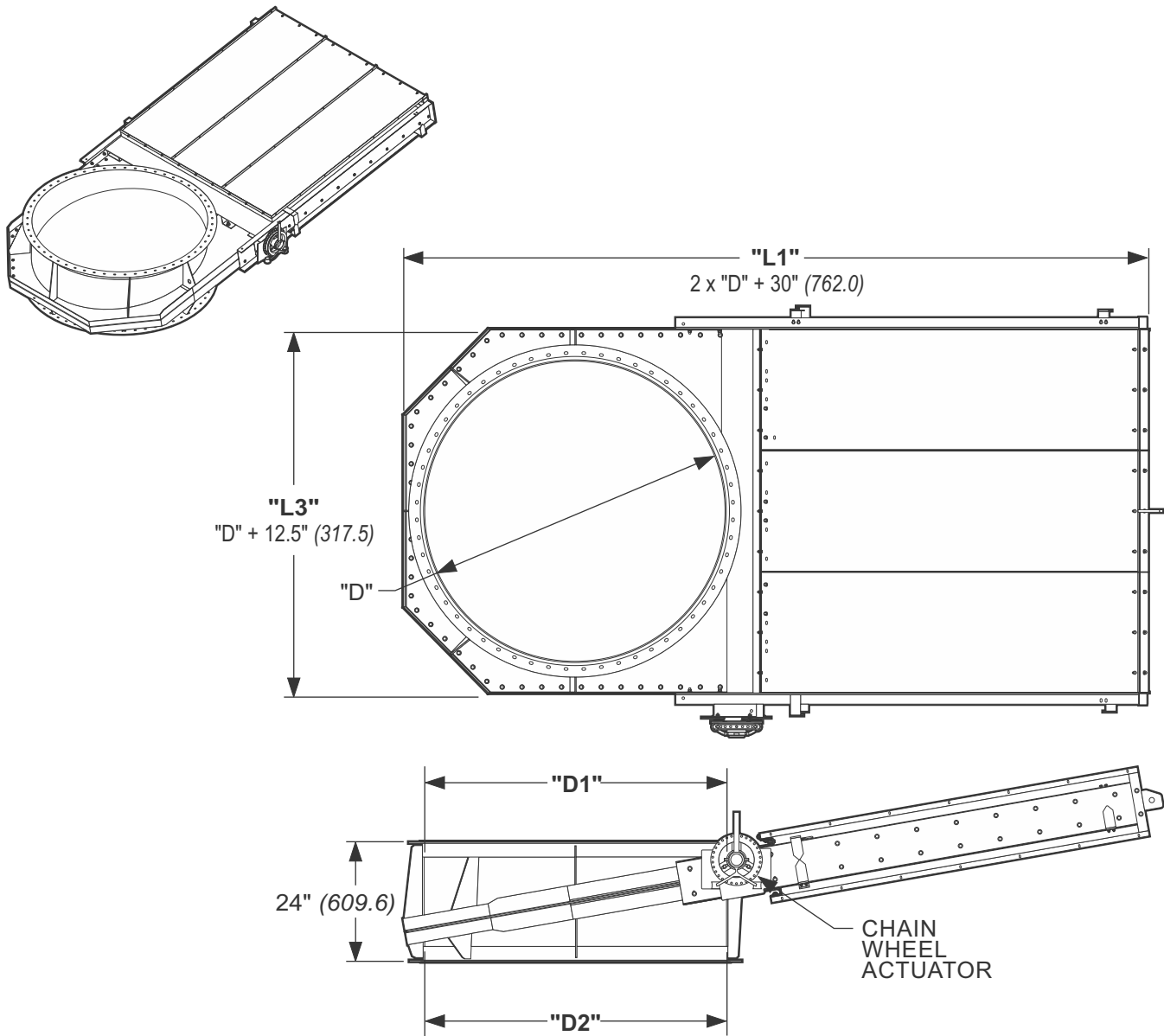

DUCT DIA. "D"	OUTSIDE DIM "L1"	BODY	BLADE	FRAME BOLTS	NO. OF BLADES	BLADE ANGLE
16" (406.4) TO 36" (914.4)	2 x D + 30" (762.0)	10GA(3.57)	12GA(2.78)	.38"(9.65)	1	10°

NOTES:

1. STAINLESS STEEL BODY, RINGS AND BLADE.
2. BLADE LOCKOUT SYSTEM.
3. EXTERIOR POSITION INDICATOR.
4. **1** **OPTION:** BELLOWS ENCLOSED LEAD SCREW FOR ADDITIONAL CORROSION RESISTANCE (ADDS TO 11 LENGTH)
5. BLASTGATES 90" (2286.0) DIAMETER AND LARGER SUBJECT TO ENGINEERING REVIEW AND APPROVAL.
6. ALL DUCT FITTINGS WITH STANDARD FAB-TECH CONNECTIONS INCLUDE GASKETS AND CLAMPS OR HARDWARE AS REQUIRED FOR INSTALLATION.

DUCT JOINT / RING TYPE

- BI** BLACK IRON ANGLE RING
4"Ø-120"Ø (101.6 - 3048.0)
- SS** STAINLESS ANGLE RING
16"Ø-120"Ø (406.4 - 3048.0)

METRIC EQUIVALENTS ARE SHOWN IN PARENTHESIS & ITALICS (MILLIMETERS OR AS NOTED)

38" (965.2) & Larger Vertical Run Isolation Blastgate

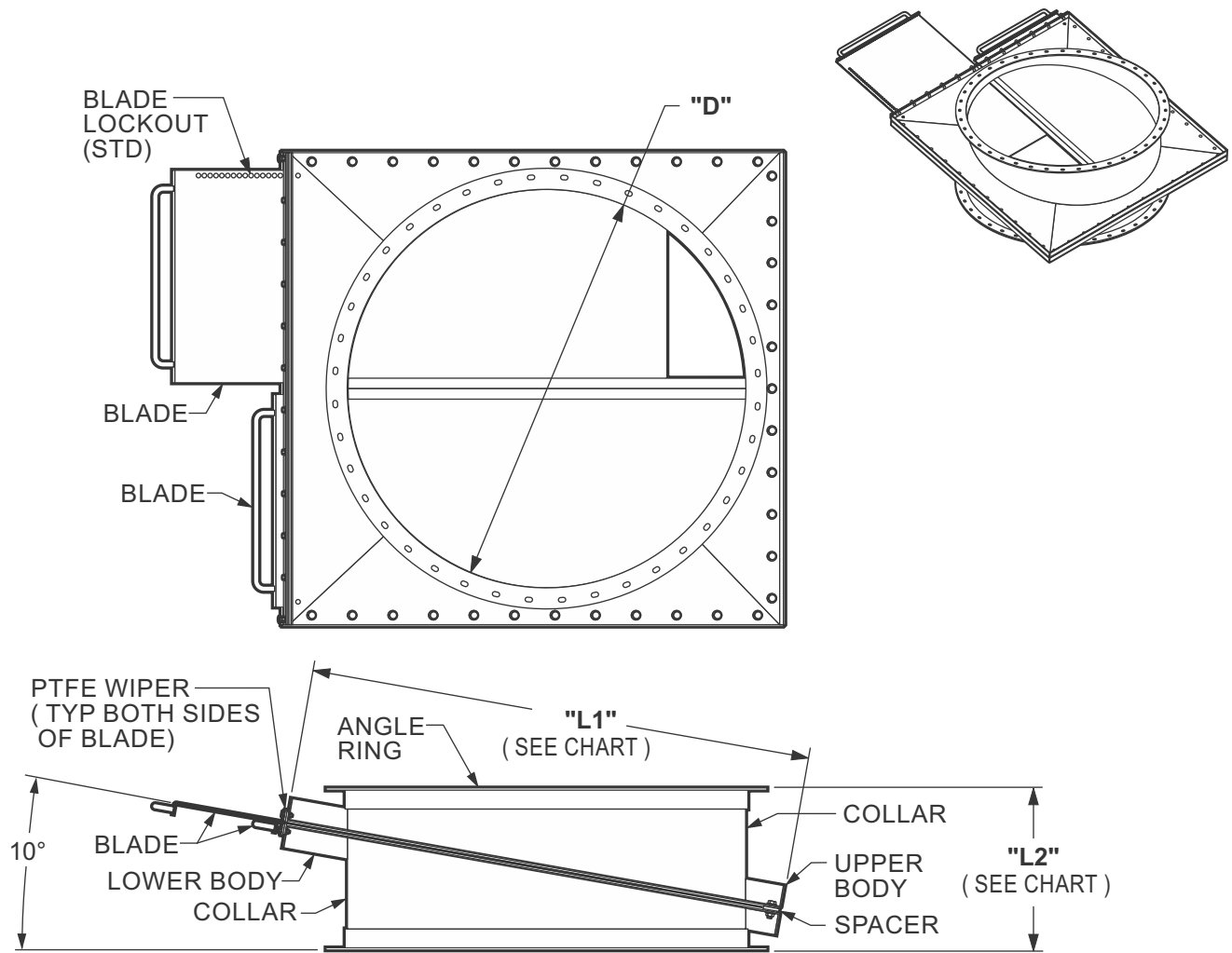

DUCT DIA. "D"	OUTSIDE DIM "L1"	BODY	BLADE	FRAME BOLTS	NO. OF BLADES	BLADE ANGLE	LENGTH "L2"
38" (965.2) TO 46" (1168.4)	DIA. "D" + 10" (254.0)	10GA (3.57)	14GA (1.98)	.31" (7.87)	2	10°	16" (406.4)
48" (1219.2) TO 60" (1524.0)	DIA. "D" + 11" (279.4)	10GA (3.57)	12GA (2.78)	.38" (9.65)	2	10°	24" (609.6)
62" (1574.8) TO 84" (2133.6)	DIA. "D" + 11" (279.4)	10GA (3.57)	12GA (2.78)	.38" (9.65)	3	10°	24" (609.6)

NOTES:

1. BLASTGATES 86" (2184.4) DIAMETER AND LARGER ARE SUBJECT TO ENGINEERING REVIEW AND APPROVAL.
2. STAINLESS STEEL BODY, RINGS AND BLADE.
3. BLADE LOCKOUT SYSTEM.
4. ALL DUCT FITTINGS WITH STANDARD FAB-TECH CONNECTIONS INCLUDE GASKETS AND CLAMPS OR HARDWARE AS REQUIRED FOR INSTALLATION.

DUCT JOINT / RING TYPE

- BI** BLACK IRON ANGLE RING
4"Ø-120"Ø (101.6 - 3048.0)
- SS** STAINLESS ANGLE RING
16"Ø-120"Ø (406.4 - 3048.0)

METRIC EQUIVALENTS ARE SHOWN IN PARENTHESIS & ITALICS (MILLIMETERS OR AS NOTED)

38" (965.2) & Larger Vertical Run Actuated Isolation Blastgate

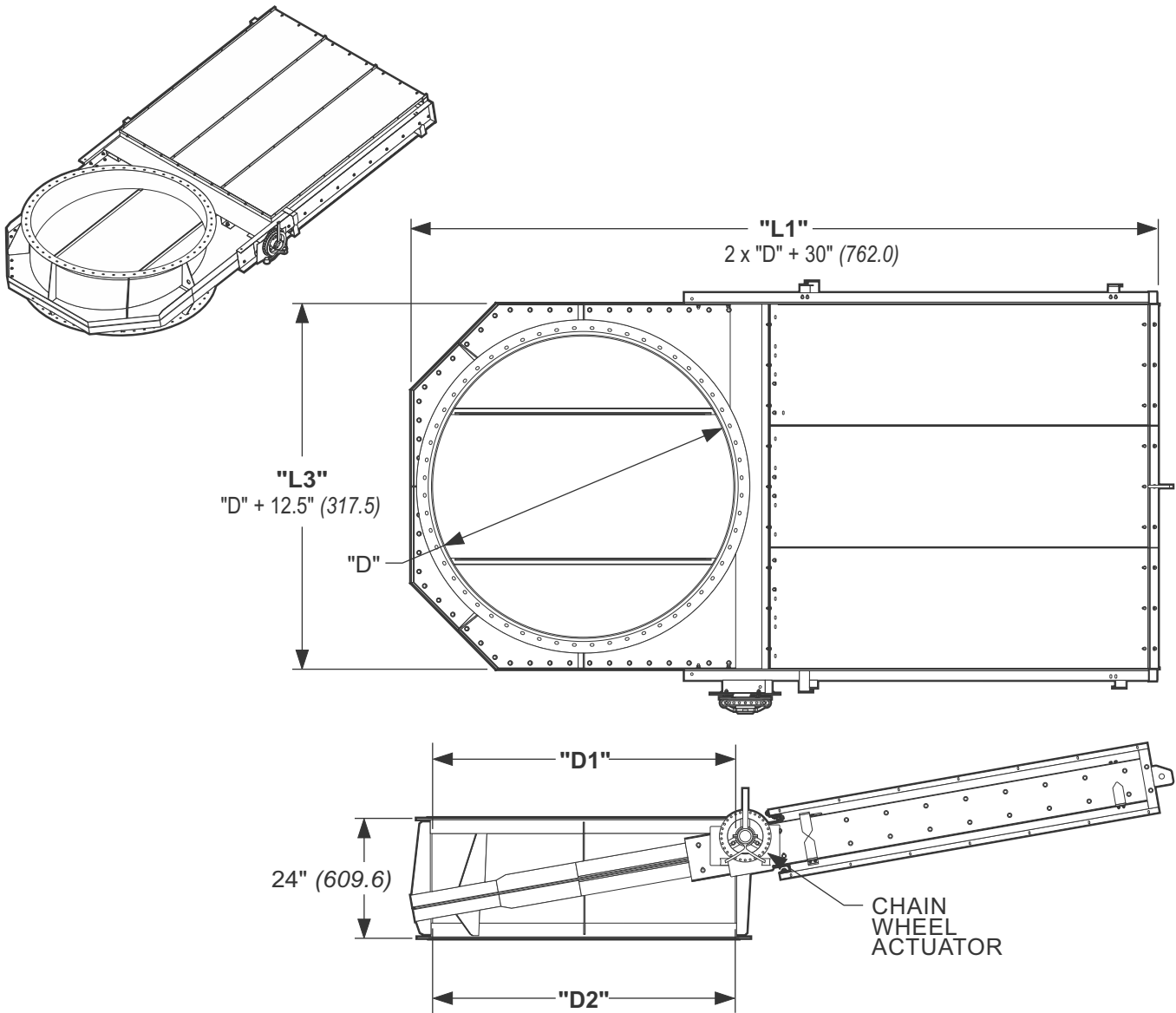

DUCT DIA. "D"	OUTSIDE DIM "L1"	BODY	BLADE	FRAME BOLTS	NO. OF BLADES	BLADE ANGLE
38"(965.2) TO 64"(1625.6)	2 x D + 30" (762.0)	10GA(3.57)	12GA(2.78)	.38"(9.65)	1	10°
66"(1676.4) TO 88"(2235.2)	2 x D + 30" (762.0)	10GA(3.57)	12GA(2.78)	.43"(10.92)	1	10°





NOTES:



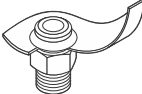

1. STAINLESS STEEL BODY, RINGS AND BLADE.
2. BLADE LOCKOUT SYSTEM.
3. EXTERIOR POSITION INDICATOR.
4. **1** **OPTION:** BELLOWS ENCLOSED LEAD SCREW FOR ADDITIONAL CORROSION RESISTANCE (ADDS TO I1 LENGTH)
5. BLASTGATES 90" (2286.0) DIAMETER AND LARGER SUBJECT TO ENGINEERING REVIEW AND APPROVAL.
6. ALL DUCT FITTINGS WITH STANDARD FAB-TECH CONNECTIONS INCLUDE GASKETS AND CLAMPS OR HARDWARE AS REQUIRED FOR INSTALLATION.

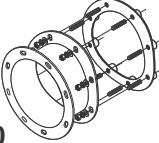
DUCT JOINT / RING TYPE

- BI** BLACK IRON ANGLE RING
4"Ø-120"Ø (101.6 - 3048.0)
- SS** STAINLESS ANGLE RING
16"Ø-120"Ø (406.4 - 3048.0)

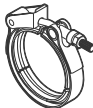
METRIC EQUIVALENTS ARE SHOWN IN PARENTHESIS & ITALICS (MILLIMETERS OR AS NOTED)

<p style="text-align: center;">ACCESSORIES</p>	<p>FIELD INSTALLED NIPPLE</p>  <p>SIZE: 1", 1-1/2", 2" <i>(25.4, 38.1, 50.8)</i></p> <p>• PAGE: 57</p>	<p>FIELD INSTALLED TEST PORT</p>  <p>SIZE: 3/8", 3/4", 2" <i>(9.5, 19.1, 50.8)</i></p> <p>• PAGE: 58</p>
<p>FIELD INSTALLED SADDLE TAP</p>  <p>SIZE: 4"-24" TEE <i>(101.6 - 609.6)</i></p> <p>• PAGE: 59</p>	<p>FIELD INSTALLED HOT TAP</p>  <p>SIZE: 4"-48" <i>(101.6 - 1219.2)</i></p> <p>• PAGE: 60</p>	<p>CAST RING STAINLESS STEEL</p>  <p>SIZE: 4"-14" <i>(101.6 - 355.6)</i></p> <p>• PAGE: 61</p>
<p>ANGLE RING STAINLESS STEEL OR BLACK IRON</p>  <p>SIZE: 4"-120" <i>(101.6 - 3048.0)</i></p> <p>• PAGE: 62</p>		

<p style="text-align: center;">ACCESSORIES PSP-EZ™</p>	<p>FIELD INSTALLED SADDLE TAP</p>  <p>SIZE: 4" TO 14" TEE <i>(101.6 - 355.6)</i></p> <p>• PAGE: 59</p>	<p>CLAMP</p>  <p>SIZE: 2" & 3" <i>(50.8 & 76.2)</i></p> <p>• PAGE: 63</p>
<p>DIE CUT GASKET</p>  <p>SIZE: 2" & 3" <i>(50.8 & 76.2)</i></p> <p>• PAGE: 63</p>	<p>CLAMP KIT</p>  <p>SIZE: 2" & 3" <i>(50.8 & 76.2)</i></p> <p>• PAGE: 63</p>	<p>CLAMP KIT</p>  <p>SIZE: 4" TO 14" <i>(101.6 - 355.6)</i></p> <p>• PAGE: 63</p>

METRIC EQUIVALENTS ARE SHOWN IN PARENTHESIS & ITALICS (MILLIMETERS OR AS NOTED)

Field Installed Nipple

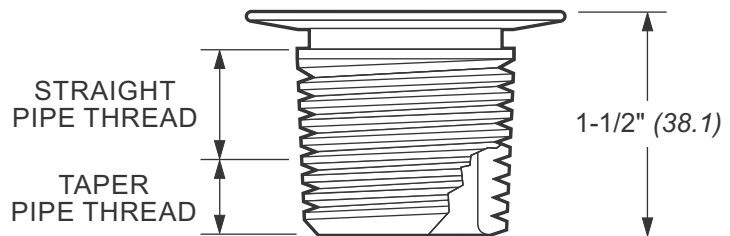
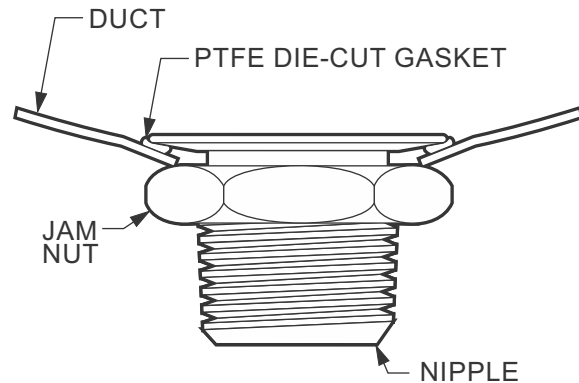
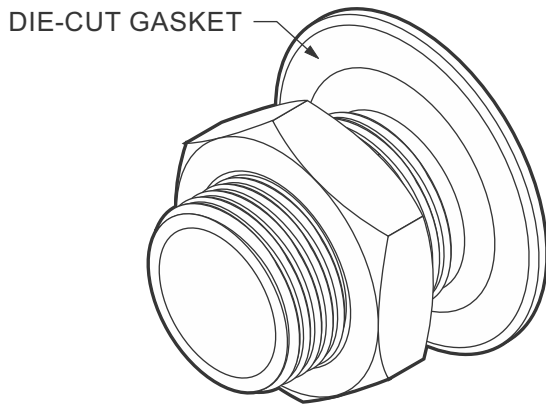

PART NO.	DESCRIPTION	MIN. HOST DUCT	MATERIAL THICKNESS
PRT01	1" NPT NIPPLE	6" (152.4) DIA. DUCT MIN.	16 GA (1.59) MAX MATERIAL THICKNESS
PRT15	1-1/2" NPT NIPPLE	8" (203.2) DIA. DUCT MIN.	
PRT02	2" NPT NIPPLE	10" (254.0) DIA. DUCT MIN.	

NOTES:

1. REFER TO FAB-TECH'S **INSTALLATION AND ASSEMBLY GUIDE** FOR ASSEMBLY INSTRUCTIONS.
2. PERMASHIELD FLUOROPOLYMER BARRIER COATING ON INSIDE SURFACE AND FLANGE FACES.
3. ALL DUCT FITTINGS WITH STANDARD FAB-TECH CONNECTIONS INCLUDE GASKETS AND CLAMPS OR HARDWARE AS REQUIRED FOR INSTALLATION.

***SWAGE KIT REQUIRED TO INSTALL**
 ONLY ONE KIT REQUIRED TO INSTALL MULTIPLE NIPPLES

PART NO.*	DESCRIPTION
TPS01	MANUAL KIT FOR 1" (25.4)
TPS02	HYDRAULIC KIT FOR 1" (25.4), 1-1/2" (38.1), & 2" (50.8)

METRIC EQUIVALENTS ARE SHOWN IN PARENTHESIS & ITALICS (MILLIMETERS OR AS NOTED)

Field Installed Test Port

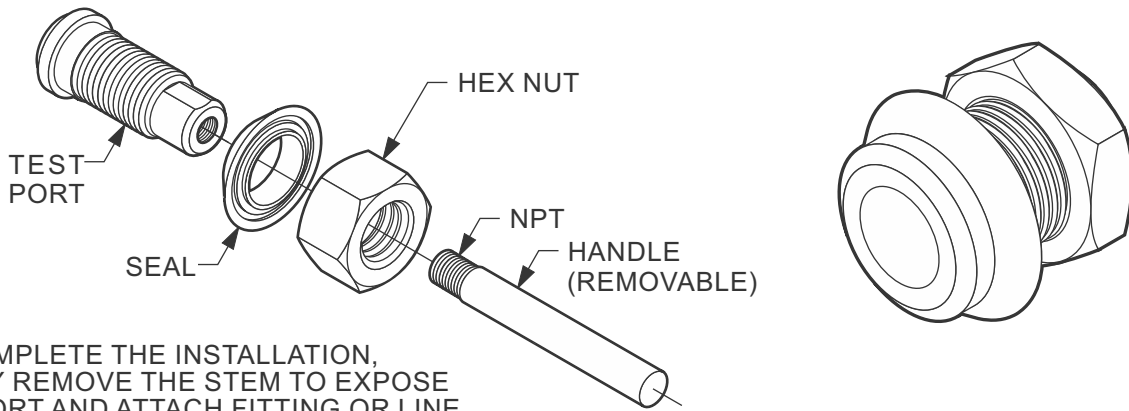

TO COMPLETE THE INSTALLATION, SIMPLY REMOVE THE STEM TO EXPOSE THE PORT AND ATTACH FITTING OR LINE.

PART NO.	DESCRIPTION	MIN. HOST DUCT	THRU HOLE	REDRILL	I.D. TAP HOLE
FTFI38TP	3/8" TEST PORT (9.5)	2" DIA. DUCT MIN. (50.8 MIN.)	1/4" DIA. (6.35)	3/8" MAX (9.5)	1/16" NPT (1.6)
FTFI34TP	3/4" TEST PORT (19.1)	6" DIA. DUCT MIN. (152.4 MIN.)	1/2" DIA. (12.7)	3/4" MAX (19.1)	1/4" NPT (6.35)
FTFI20TP	2" TEST PORT (50.8)	12" DIA. DUCT MIN. (304.8 MIN.)	9/16" DIA. (14.29)	1-3/4" MAX (44.5)	3/8" NPT (9.5)

NOTES:

1. REFER TO FAB-TECH'S **INSTALLATION AND ASSEMBLY GUIDE** FOR ASSEMBLY INSTRUCTIONS.
2. PERMASHIELD FLUOROPOLYMER BARRIER COATING ON INSIDE SURFACE AND FLANGE FACES.
3. NIPPLE MADE OF PURE PVDF, SEAL MADE OF VITON, STAINLESS STEEL HEX NUT.
4. ABLE TO RE-DRILL THROUGH HOLE TO SLIGHTLY LARGER HOLE OR DRILL AND TAP TEST PORT FOR FEMALE THREADS - THREAD O.D. CANNOT EXCEED MAX RE-DRILL DIAMETER.
5. INSTALLS IN DUCT AS SMALL AS 2" (50.8) DIAMETER - PROVIDES LIQUID TIGHT SEAL - DOES NOT COMPROMISE THE INTEGRITY OF THE DUCT INTERIOR COATING.
6. THE UNIQUE HANDLE DESIGN OF THIS TEST PORT ALLOWS IT TO BE INSTALLED QUICKLY AND EASILY IN-THE-FIELD WITH COMMON TOOLS AND WITHOUT SYSTEM SHUTDOWN OR DISASSEMBLY.

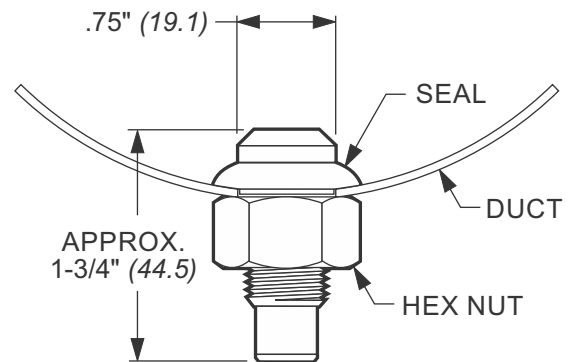

3/8" (9.5) TEST PORT

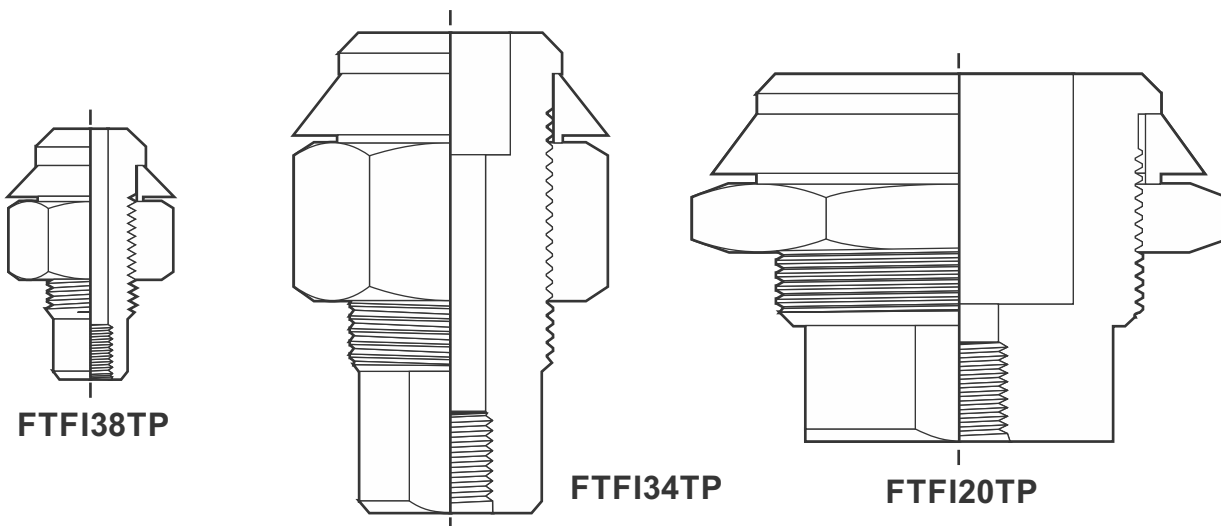

METRIC EQUIVALENTS ARE SHOWN IN PARENTHESIS & ITALICS (MILLIMETERS OR AS NOTED)

Field Installed Saddle Tap

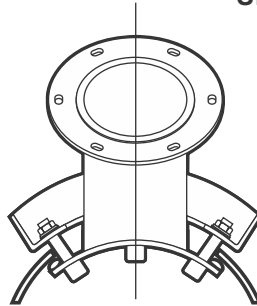
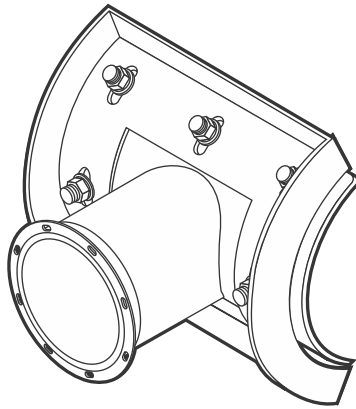

SECTION THROUGH DUCT - LATERAL TAP

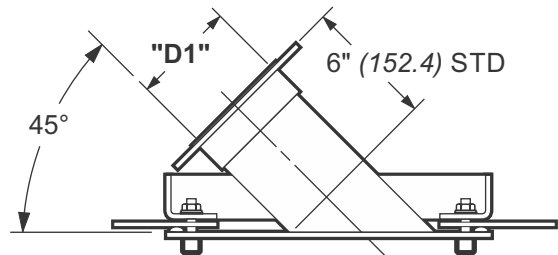

HOST DUCT I.D., WALL THICKNESS & MATERIAL TYPE
(REQUIRED INFORMATION)

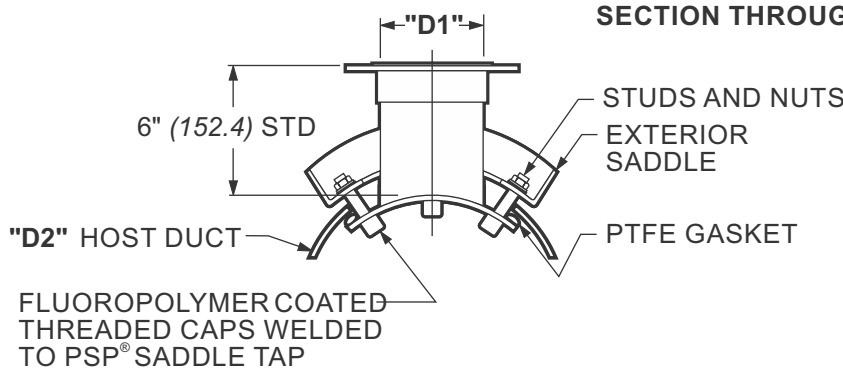

SECTION THROUGH DUCT - STRAIGHT TAP

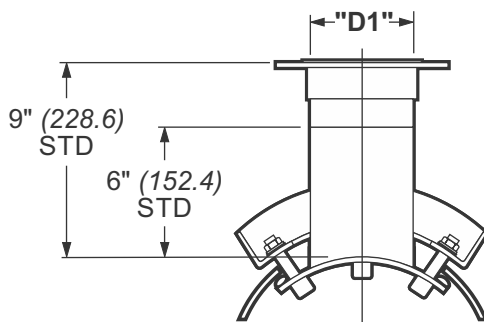
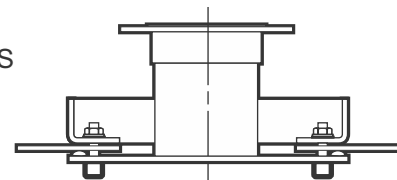

SECTION THROUGH DUCT - BOOT TAP

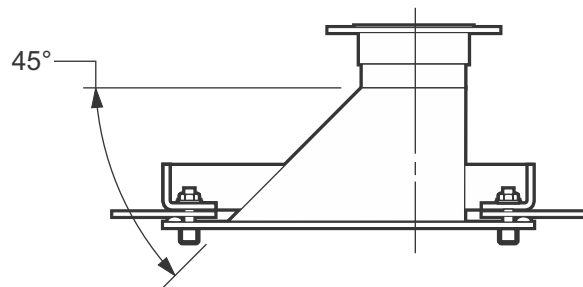

NOTES:

1. REFER TO FAB-TECH'S **INSTALLATION AND ASSEMBLY GUIDE** FOR ASSEMBLY INSTRUCTIONS.
2. PERMASHIELD FLUOROPOLYMER BARRIER COATING ON INSIDE SURFACE AND FLANGE FACES.
3. FAB-TECH'S PERMASHIELD SADDLE TAP WILL ALLOW A NEW BRANCH TO BE INSTALLED WITHOUT SHUTTING DOWN OR DISMANTLING THE EXHAUST SYSTEM.
4. STRAIGHT TAP STANDARD - OTHER TAP STYLES AVAILABLE WITH ENGINEERING REVIEW AND APPROVAL.
5. ALL DUCT FITTINGS WITH STANDARD FAB-TECH CONNECTIONS INCLUDE GASKETS AND CLAMPS OR HARDWARE AS REQUIRED FOR INSTALLATION.

DUCT JOINT / RING TYPE

- EZ** EZ CLAMP
4"Ø-14"Ø (101.6 - 355.6)
- SC** STAINLESS CAST RING
4"Ø-14"Ø (101.6 - 355.6)
- BI** BLACK IRON ANGLE RING
4"Ø-120"Ø (101.6 - 3048.0)
- SS** STAINLESS ANGLE RING
16"Ø-120"Ø (406.4 - 3048.0)

METRIC EQUIVALENTS ARE SHOWN IN PARENTHESIS & ITALICS (MILLIMETERS OR AS NOTED)

Field Installed Hot Tap

HOST DUCT I.D., PRESSURE CLASS & MATERIAL TYPE
(REQUIRED INFORMATION)

SECTION THROUGH DUCT - HOT TAP

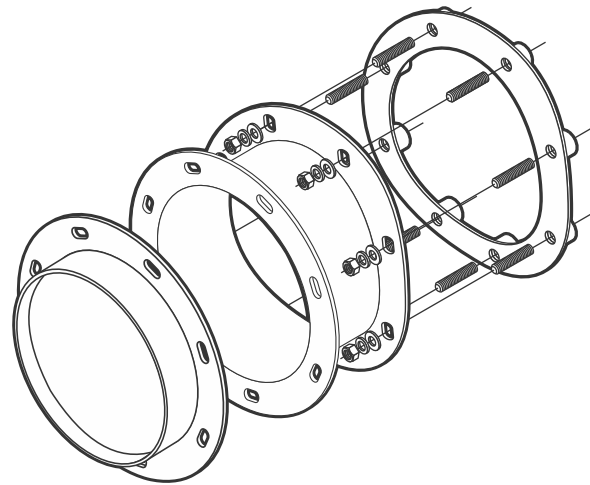
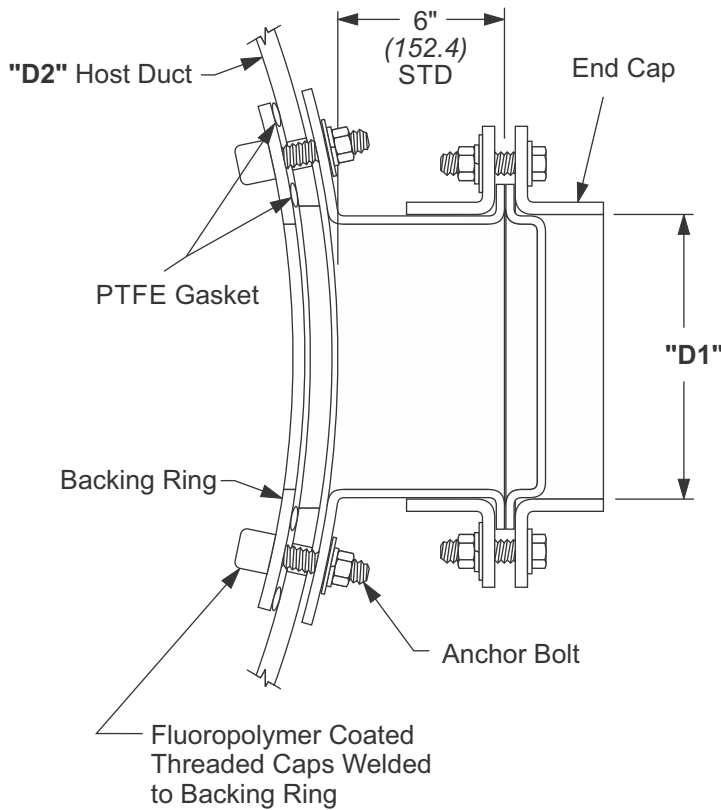

ALLOWABLE TAP SIZE CHART

Tap Size Dia.	Minimum Host Dia.
4 (101.6)	10 (254.0)
6 (152.4)	10 (254.0)
8 (203.2)	14 (355.6)
10 (254.0)	16 (406.4)
12 (304.8)	20 (508.0)
14 (355.6)	22 (558.8)
16 (406.4)	26 (660.4)
18 (457.2)	28 (711.2)
20 (508.0)	32 (812.8)
22 (558.8)	34 (863.6)
24 (609.6)	38 (965.2)
26 (660.4)	40 (1016.0)
28 (711.2)	44 (1117.6)
30 (762.0)	48 (1219.2)
32 (812.8)	50 (1270.0)
34 (863.6)	54 (1371.6)
36 (914.4)	56 (1422.4)
38 (965.2)	60 (1524.0)
40 (1016.0)	62 (1574.8)
42 (1066.8)	66 (1676.4)
44 (1117.6)	68 (1727.2)
46 (1168.4)	72 (1828.8)
48 (1219.2)	74 (1879.6)

DUCT JOINT / RING TYPE

- SC** STAINLESS CAST RING
4"Ø-14"Ø (101.6 - 355.6)
- BI** BLACK IRON ANGLE RING
4"Ø-120"Ø (101.6 - 3048.0)
- SS** STAINLESS ANGLE RING
16"Ø-120"Ø (406.4 - 3048.0)

NOTES:

1. REFER TO FAB-TECH'S **INSTALLATION AND ASSEMBLY GUIDE** FOR ASSEMBLY INSTRUCTIONS.
2. PERMASHIELD FLUOROPOLYMER BARRIER COATING ON BACKING RING AND INTERIOR SURFACES.
3. ONLY STRAIGHT TAP AVAILABLE FOR THIS TAP CONFIGURATION.
4. ISOLATION BOX REQUIRED FOR INSTALLATION.
5. FAB-TECH'S PERMASHIELD FIELD INSTALLED HOT TAP WILL ALLOW A NEW BRANCH TO BE INSTALLED IN AN EXISTING SYSTEM WITHOUT SHUTTING DOWN THE EXHAUST SYSTEM.
6. ALL DUCT FITTINGS WITH STANDARD FAB-TECH CONNECTIONS INCLUDE GASKETS AND CLAMPS OR HARDWARE AS REQUIRED FOR INSTALLATION.
7. ONLY FOR HOST DUCT APPLICATIONS THAT ARE 14GA (2MM) OR THINNER.

METRIC EQUIVALENTS ARE SHOWN IN PARENTHESIS & ITALICS (MILLIMETERS OR AS NOTED)

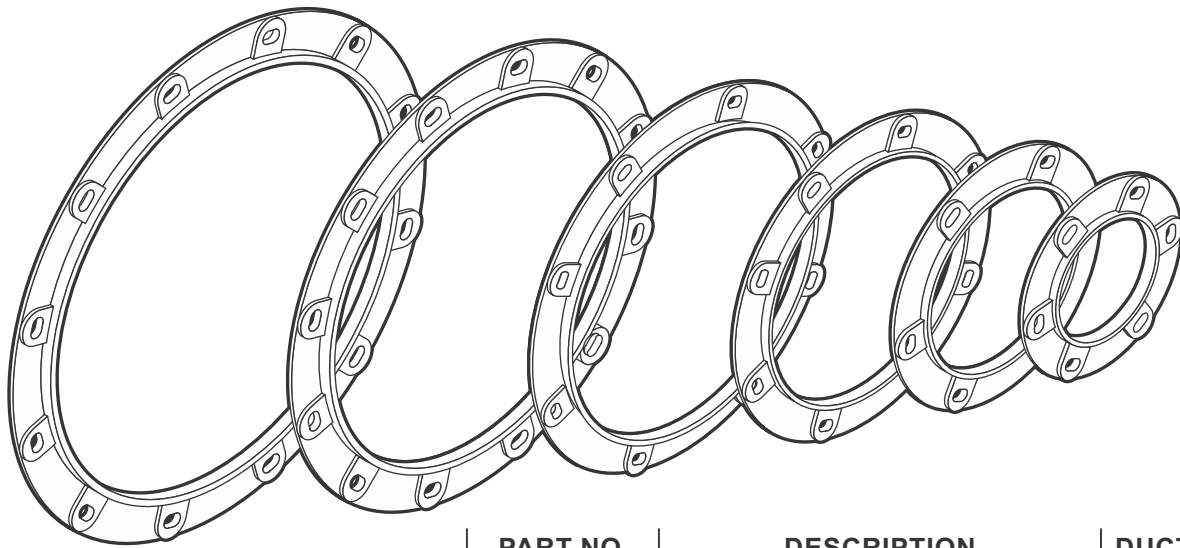

PART NO.	DESCRIPTION	DUCT DIA.
RC04	STAINLESS STEEL CAST RING	4" (101.6)
RC06	STAINLESS STEEL CAST RING	6" (152.4)
RC08	STAINLESS STEEL CAST RING	8" (203.2)
RC10	STAINLESS STEEL CAST RING	10" (254.0)
RC12	STAINLESS STEEL CAST RING	12" (304.8)
RC14	STAINLESS STEEL CAST RING	14" (355.6)

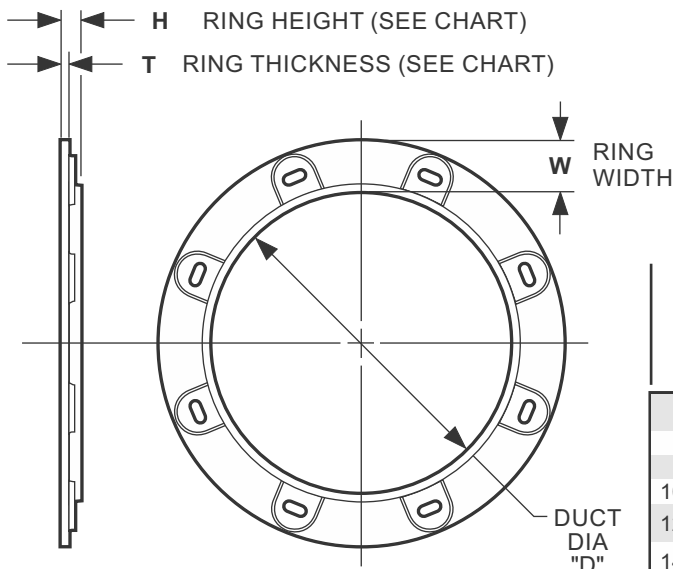

DUCT DIA "D"	CAST RING SPECIFICATIONS						BOLT CIRCLE DIA.
	WIDTH (W)	HEIGHT (H)	THICKNESS (T)	# HOLES	BOLT HOLE SIZE	BOLT SIZE	
4 (101.6)	1-1/4" (31.8)	13/32" (10.32)	1/8" (3.18)	6	7/16" x 11/16"	3/8 (9.5)	5.31 (134.9)
6 (152.4)					7/16" x 11/16"		7.50 (190.5)
8 (203.2)				8	7/16" x 11/16"	9.50 (241.3)	
10 (254.0)	1-1/2" (38.1)	1/2" (12.7)	3/16" (4.76)	12	9/16" x 3/4" (14.3 x 19.1)	1/2 (12.7)	11.50 (292.1)
12 (304.8)							13.81 (350.8)
14 (355.6)							15.81 (401.6)

NOTES:

1. REFER TO FAB-TECH'S **INSTALLATION AND ASSEMBLY GUIDE** FOR ASSEMBLY INSTRUCTIONS.
2. ALL DUCT FITTINGS WITH STANDARD FAB-TECH CONNECTIONS INCLUDE GASKETS AND CLAMPS OR HARDWARE AS REQUIRED FOR INSTALLATION.

METRIC EQUIVALENTS ARE SHOWN IN PARENTHESIS & ITALICS (MILLIMETERS OR AS NOTED)

Angle Ring

DUCT DIA "D"	ANGLE RING SPECIFICATIONS					BOLT CIRCLE DIA.
	WIDTH (W)	THICKNESS (T)	# HOLES	BOLT HOLE SIZE	BOLT SIZE	
4 (101.6)	1" (25.4)	1/8" (3.18)	6	7/16" (11.1)	3/8" (9.53)	5.31 (134.87)
6 (152.4)	1-1/4" (31.8)	1/8" (3.18)	8	7/16" x 11/16" (11.1 x 17.5)	3/8" (9.53)	7.50 (190.5)
8 (203.2)						9.50 (241.3)
10 (254.0)	1-1/2" (38.1)	3/16" (4.76)	12	7/16" x 11/16" (11.1 x 17.5)	3/8" (9.53)	11.50 (292.1)
12 (304.8)						13.81 (350.77)
14 (355.6)						15.81 (401.57)
16 (406.4)						17.76 (451.10)
18 (457.2)						19.76 (501.9)
20 (508.0)						21.76 (552.7)
22 (558.8)						23.88 (606.55)
24 (609.6)						25.88 (657.35)
26 (660.4)						27.88 (708.15)
28 (711.2)						29.88 (758.95)
30 (762.0)	2" (50.8)	3/16" (4.76)	24	7/16" x 11/16" (11.1 x 17.5)	3/8" (9.53)	31.88 (809.75)
32 (812.8)						33.88 (860.55)
34 (863.6)						35.88 (911.35)
36 (914.4)						37.88 (962.15)
38 (965.2)						40.38 (1025.65)
40 (1016.0)						42.38 (1076.45)
42 (1066.8)						44.38 (1127.25)
44 (1117.6)						46.38 (1178.05)
46 (1168.4)						48.38 (1228.85)
48 (1219.2)						50.38 (1279.65)
50 (1270.0)	2-1/2" (63.5)	3/16" (4.76)	28	7/16" x 11/16" (11.1 x 17.5)	3/8" (9.53)	52.88 (1343.15)
52 (1320.8)						54.88 (1393.95)
54 (1371.6)						56.88 (1444.75)
56 (1422.4)						58.88 (1495.55)
58 (1473.2)						60.88 (1546.35)
60 (1524.0)						62.88 (1597.15)
62 (1574.8)						64.88 (1647.95)
64 (1625.6)						66.88 (1698.75)
66 (1676.4)						68.88 (1749.55)
68 (1727.2)						70.88 (1800.35)
70 (1778.0)	3" (76.2)	3/16" (4.76)	32	7/16" x 11/16" (11.1 x 17.5)	3/8" (9.53)	72.88 (1851.15)
72 (1828.8)						74.88 (1901.95)
74 (1879.6)						76.88 (1952.75)
76 (1930.4)						78.88 (2003.55)
78 (1981.2)						80.88 (2054.35)
80 (2032.0)						82.88 (2105.15)
82 (2082.8)						84.88 (2155.95)
84 (2133.6)						86.88 (2206.75)
86 (2184.4)						89.38 (2270.25)
88 (2235.2)						91.38 (2321.05)
90 (2286.0)	1/4" (6.35)	3/16" (4.76)	36	7/16" x 11/16" (11.1 x 17.5)	3/8" (9.53)	93.38 (2371.85)
92 (2336.8)						95.38 (2422.65)
94 (2387.6)						97.38 (2473.45)
96 (2438.4)						100.38 (2549.65)
98 (2489.2)						102.38 (2600.45)
100 (2540.0)						104.38 (2651.25)
102 (2590.8)						106.38 (2702.05)
104 (2641.6)						108.38 (2752.85)
106 (2692.4)						110.38 (2803.65)
108 (2743.2)						112.38 (2854.45)
110 (2794.0)	4" (101.6)	3/16" (4.76)	40	7/16" x 11/16" (11.1 x 17.5)	3/8" (9.53)	114.38 (2905.25)
112 (2844.8)						116.38 (2956.05)
114 (2895.6)						118.38 (3006.85)
116 (2946.4)						120.38 (3057.65)
118 (2997.2)						122.38 (3108.45)
120 (3048.0)						124.38 (3159.25)

DUCT JOINT / RING TYPE

- BI** BLACK IRON ANGLE RING
4"Ø-120"Ø (101.6 - 3048.0)
- SS** STAINLESS ANGLE RING
16"Ø-120"Ø (406.4 - 3048.0)

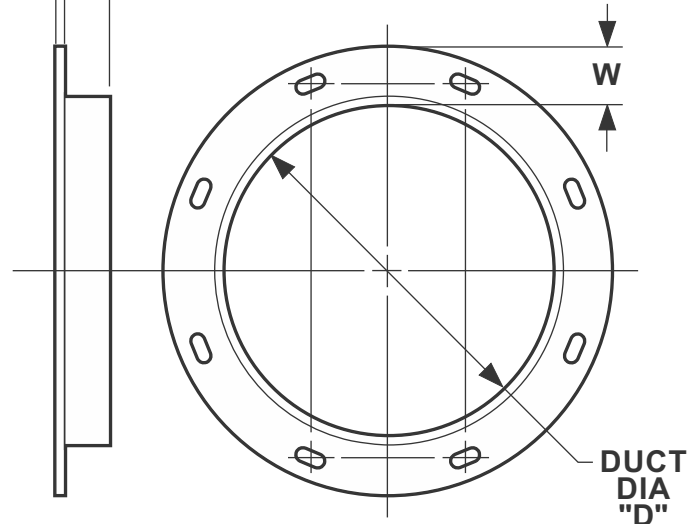
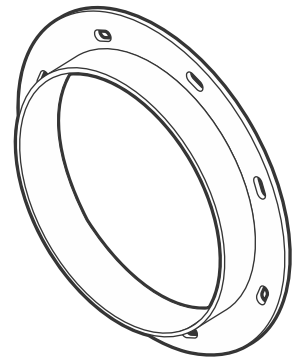

NOTES:

1. STANDARD MOUNTING HOLE LOCATIONS FOR WELDED (FIXED) ANGLE RINGS STRADDLE THE VERTICAL CENTERLINE UNLESS OTHERWISE SPECIFIED.
2. **1 OPTION:** CUSTOM HOLE PATTERN
3. **2 OPTION:** CUSTOM ORIENTATION
4. ALL DUCT FITTINGS WITH STANDARD FAB-TECH CONNECTIONS INCLUDE GASKETS AND CLAMPS OR HARDWARE AS REQUIRED FOR INSTALLATION.

METRIC EQUIVALENTS ARE SHOWN IN PARENTHESIS & ITALICS (MILLIMETERS OR AS NOTED)

PSP-EZ™ Clamp Kit

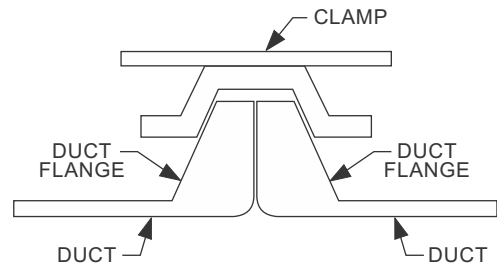
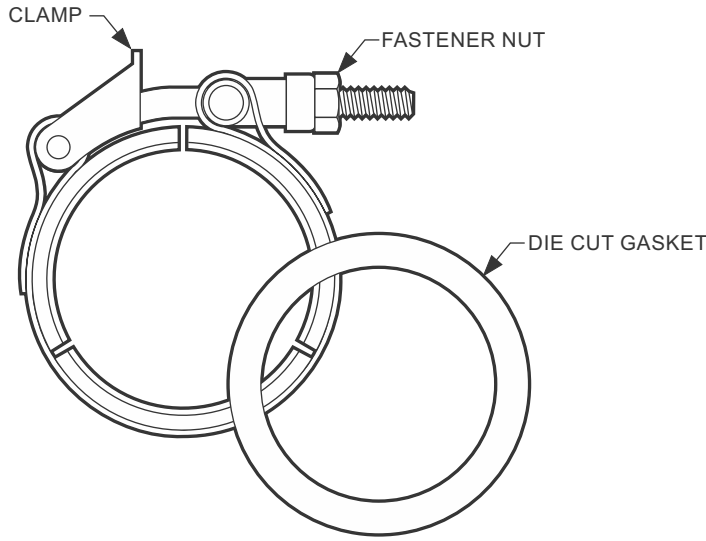

**CROSS SECTION OF
2" (50.8) & 3" (76.2) PSP-EZ™ JOINT**

PART NO.	DESCRIPTION	DUCT DIA.
CL002KT	2" CLAMP KIT	2" (50.8)
CL003KT	3" CLAMP KIT	3" (76.2)
CL002	2" CLAMP	2" (50.8)
CL003	3" CLAMP	3" (76.2)
GAS11	2" GASKET	2" (50.8)
GAS13	3" GASKET	3" (76.2)

Each Kit above contains a clamp and PTFE die cut gasket

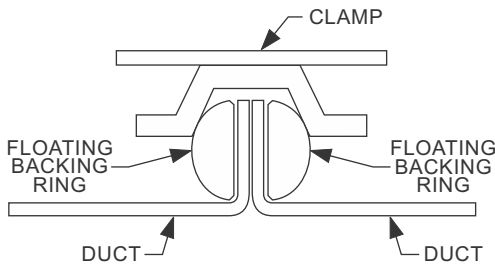







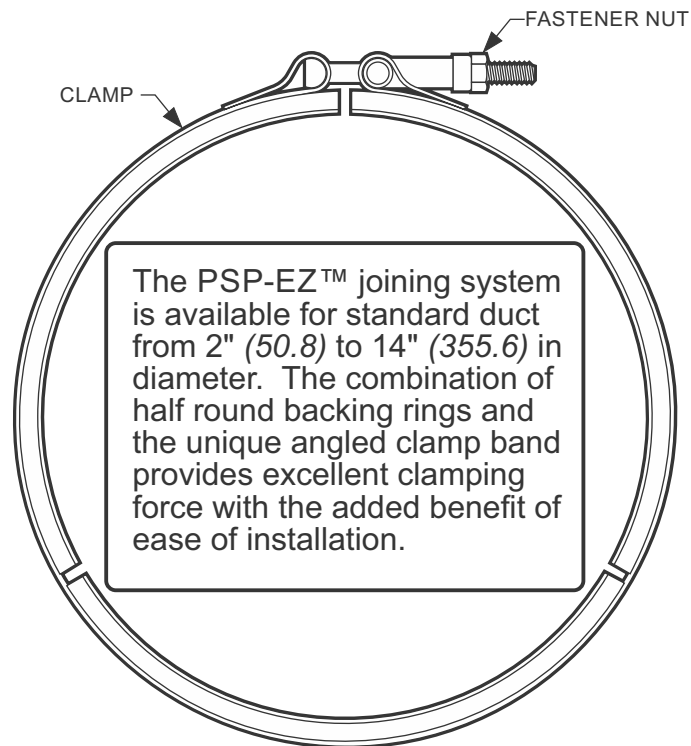

**CROSS SECTION OF
4" (101.6) - 14" (355.6) PSP-EZ™ JOINT**

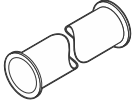
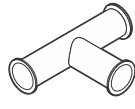
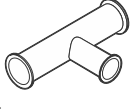
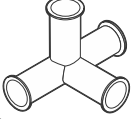
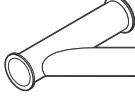
PART NO.	DESCRIPTION	DUCT DIA.
CL004KT	4" CLAMP KIT	4" (101.6)
CL006KT	6" CLAMP KIT	6" (152.4)
CL008KT	8" CLAMP KIT	8" (203.2)
CL010KT	10" CLAMP KIT	10" (254.0)
CL012KT	12" CLAMP KIT	12" (304.8)
CL014KT	14" CLAMP KIT	14" (355.6)

Each Kit above contains a clamp, PTFE tape gasket, and two backing rings

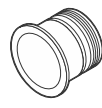
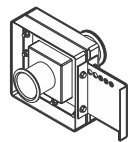

METRIC EQUIVALENTS ARE SHOWN IN PARENTHESIS & ITALICS (MILLIMETERS OR AS NOTED)

<p>2" (50.8) & 3" (76.2) PSP-EZ™ CLAMP</p>	<p>STRAIGHT DUCT 4' LENGTH OR CUSTOM SIZE: 2" & 3" (50.8 & 76.2) ● PAGE: 65</p> 	<p>STRAIGHT TEE SIZE: 2" & 3" (50.8 & 76.2) ● PAGE: 65</p> 
<p>REDUCING TEE SIZE: 3" TO 2" (76.2 TO 50.8) ● PAGE: 65</p> 	<p>DOUBLE TEE SIZE: 2" & 3" (50.8 & 76.2) ● PAGE: 66</p> 	<p>LATERAL - 45° SIZE: 2" & 3" (50.8 & 76.2) ● PAGE: 66</p> 
<p>ELBOW 90° SIZE: 2" & 3" (50.8 & 76.2) ● PAGE: 66</p> 	<p>ELBOW 45° SIZE: 2" & 3" (50.8 & 76.2) ● PAGE: 67</p> 	<p>ELBOW 30° SIZE: 2" & 3" (50.8 & 76.2) ● PAGE: 67</p> 
<p>ECCENTRIC ADAPTER SIZE: 3" (76.2) TO 2" (50.8) 4" (101.6) TO 2" (50.8) 4" (101.6) TO 3" (76.2) ● PAGE: 67</p> 	<p>CONCENTRIC ADAPTER SIZE: 3" (76.2) TO 2" (50.8) 4" (101.6) TO 2" (50.8) 4" (101.6) TO 3" (76.2) ● PAGE: 68</p> 	<p>VAN STONE TO EZ FLANGE ADAPTER SIZE: 3" (76.2) TO 2" (50.8) 4" (101.6) TO 2" (50.8) 4" (101.6) TO 3" (76.2) ● PAGE: 68</p> 
<p>END CAP SIZE: 2" & 3" (50.8 & 76.2) ● PAGE: 68</p> 	<p>MICRO ADJUSTABLE DAMPER SIZE: 2" & 3" (50.8 & 76.2) ● PAGE: 69</p> 	<p>FIELD INSTALL STRAIGHT DUCT FLANGE SIZE: 2" & 3" (50.8 & 76.2) ● PAGE: 70</p> 
<p>BLASTGATE SIZE: 2" & 3" (50.8 & 76.2) ● PAGE: 71</p> 		

METRIC EQUIVALENTS ARE SHOWN IN PARENTHESIS & ITALICS (MILLIMETERS OR AS NOTED)

EZ Straight

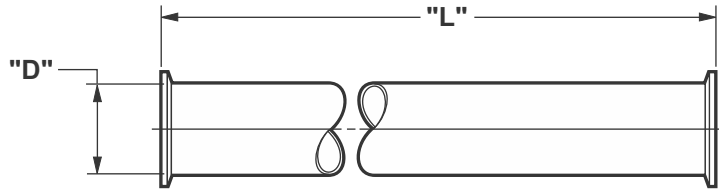
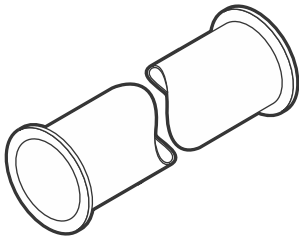

PART NO.	DESCRIPTION	"D"	"L"
PZP002	2" LINE	2" (50.8)	47.25" (1200.2)
PZS002	2" LINE CUSTOM LENGTH	2" (50.8)	CUSTOM
PZP003	3" LINE	3" (76.2)	47.25" (1200.2)
PZS003	3" LINE CUSTOM LENGTH	3" (76.2)	CUSTOM

All fittings with standard Fab-Tech connections include gaskets and clamps or hardware as required for installation.

EZ Tee

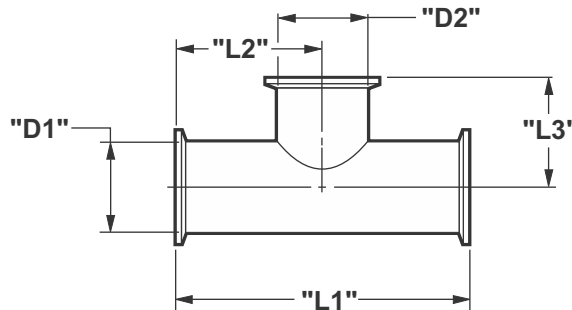
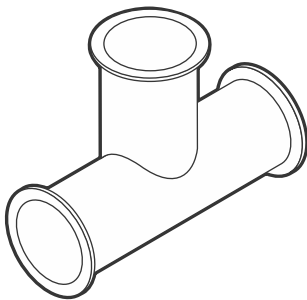

PART NO.	DESCRIPTION	"D1"	"D2"	"L1"	"L2"	"L3"
02T02	2" LINE WITH 2" TEE	2" (50.8)	2" (50.8)	6.24" (158.5)	3.12" (79.2)	3.12" (79.2)
03T03	3" LINE WITH 3" TEE	3" (76.2)	3" (76.2)	6.74" (171.2)	3.37" (85.6)	3.37" (85.6)

All fittings with standard Fab-Tech connections include gaskets and clamps or hardware as required for installation.

EZ Reducing Tee

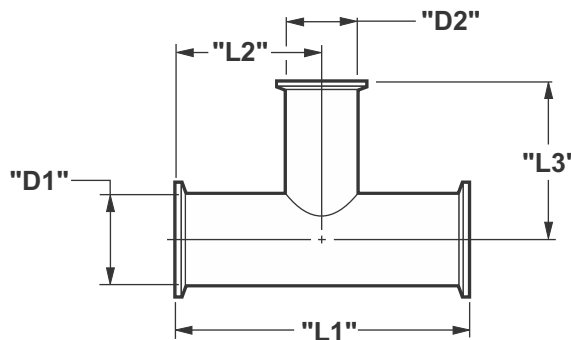
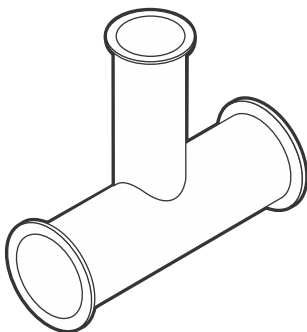

PART NO.	DESCRIPTION	"D1"	"D2"	"L1"	"L2"	"L3"
03T02	3" LINE WITH 2" TEE	3" (76.2)	2" (50.8)	6.74" (171.2)	3.37" (85.6)	3.62" (91.9)

All fittings with standard Fab-Tech connections include gaskets and clamps or hardware as required for installation.

METRIC EQUIVALENTS ARE SHOWN IN PARENTHESIS & ITALICS (MILLIMETERS OR AS NOTED)

EZ Double Tee

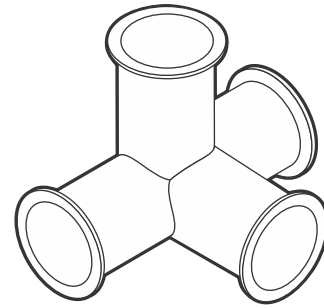
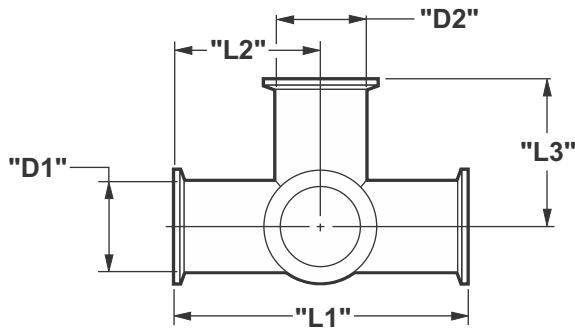

PART NO.	DESCRIPTION	"D1"	"D2"	"L1"	"L2"	"L3"
2T2T2	2" LINE W/ DOUBLE 2" TEE	2" (50.8)	2" (50.8)	6.24" (158.5)	3.12" (79.2)	3.12" (79.2)

All fittings with standard Fab-Tech connections include gaskets and clamps or hardware as required for installation.

EZ Lateral

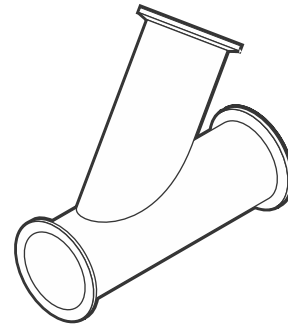
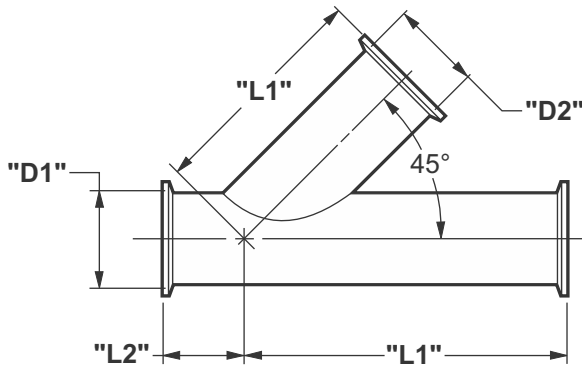

PART NO.	DESCRIPTION	"D1"	"D2"	"L1"	"L2"
02Y02	2" LINE WITH 2" LATERAL	2" (50.8)	2" (50.8)	7.25" (184.2)	2.00" (50.8)
03Y03	3" LINE WITH 3" LATERAL	3" (76.2)	3" (76.2)	9.31" (236.5)	2.03" (51.6)

All fittings with standard Fab-Tech connections include gaskets and clamps or hardware as required for installation.

90° EZ Elbow

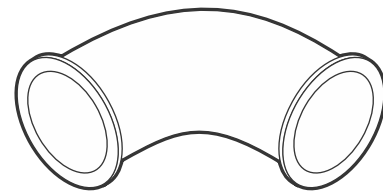
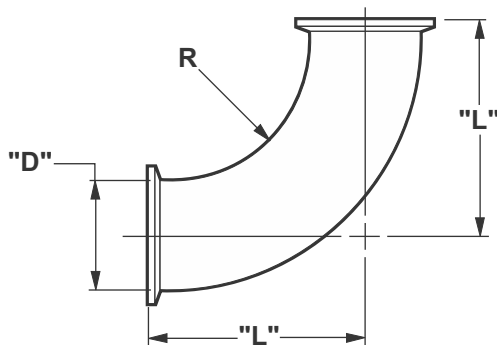

PART NO.	DESCRIPTION	"D"	"L"	R
PZE02	2" 90° ELBOW	2" (50.8)	3.12" (79.2)	2" (50.8)
PZE03	3" 90° ELBOW	3" (76.2)	4.62" (117.3)	3" (76.2)

All fittings with standard Fab-Tech connections include gaskets and clamps or hardware as required for installation.

METRIC EQUIVALENTS ARE SHOWN IN PARENTHESIS & ITALICS (MILLIMETERS OR AS NOTED)

45° EZ Elbow

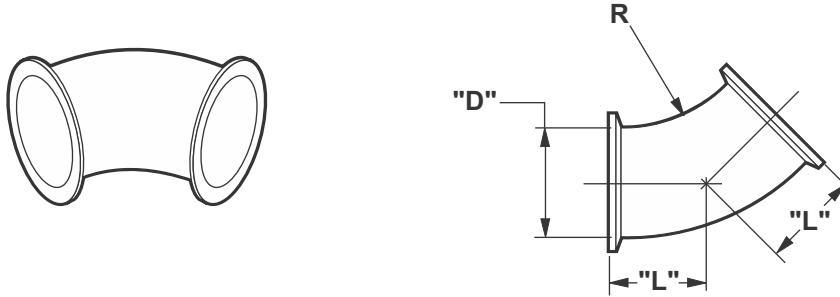

PART NO.	DESCRIPTION	"D"	"L"	R
PZ502	2" 45° ELBOW	2" (50.8)	1.37" (34.8)	2" (50.8)
PZ503	3" 45° ELBOW	3" (76.2)	2.00" (50.8)	3" (76.2)

All fittings with standard Fab-Tech connections include gaskets and clamps or hardware as required for installation.

30° EZ Elbow

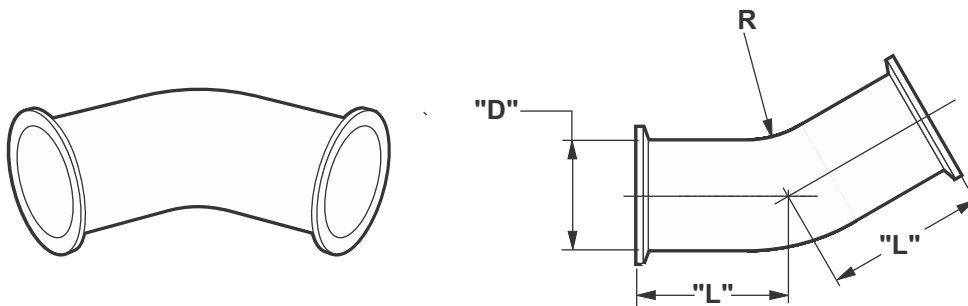

PART NO.	DESCRIPTION	"D"	"L"	R
PZ302	2" 30° ELBOW	2" (50.8)	1.94" (49.3)	2" (50.8)
PZ303	3" 30° ELBOW	3" (76.2)	2.38" (60.5)	3" (76.2)

All fittings with standard Fab-Tech connections include gaskets and clamps or hardware as required for installation.

Eccentric EZ Reducer

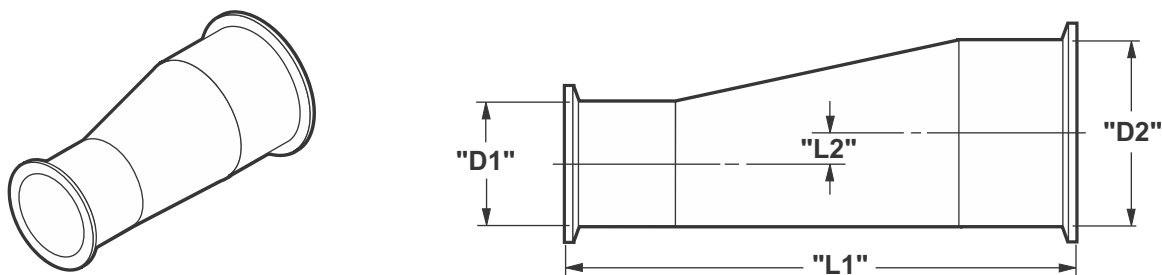

PART NO.	DESCRIPTION	"D1"	"D2"	"L1"	"L2"
PEA32F	2" TO 3" ECCENTRIC	2" (50.8)	3" (76.2)	8.25" (209.6)	0.50" (12.7)
PEA42F	2" TO 4" ECCENTRIC	2" (50.8)	4" (101.6)	12.75" (323.9)	1.00" (25.4)
PEA43F	3" TO 4" ECCENTRIC	3" (76.2)	4" (101.6)	8.00" (203.2)	0.50" (12.7)

All fittings with standard Fab-Tech connections include gaskets and clamps or hardware as required for installation.

METRIC EQUIVALENTS ARE SHOWN IN PARENTHESIS & ITALICS (MILLIMETERS OR AS NOTED)

Concentric EZ Reducer

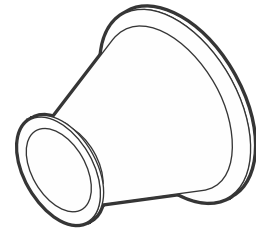
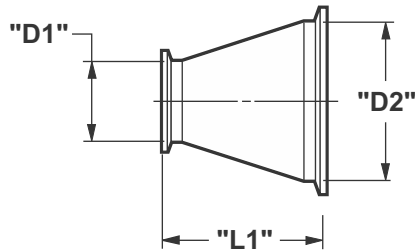

PART NO.	DESCRIPTION	"D1"	"D2"	"L1"
PCA32F	2" TO 3" CONCENTRIC	2" (50.8)	3" (76.2)	4.31" (109.5)
PCA42F	2" TO 4" CONCENTRIC	2" (50.8)	4" (101.6)	3.94" (100.1)
PCA43F	3" TO 4" CONCENTRIC	3" (76.2)	4" (101.6)	4.31" (109.5)

All fittings with standard Fab-Tech connections include gaskets and clamps or hardware as required for installation.

Angle Ring to EZ Reducer

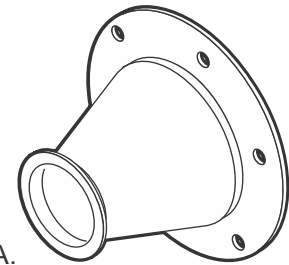
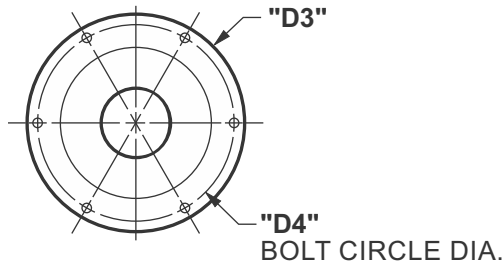
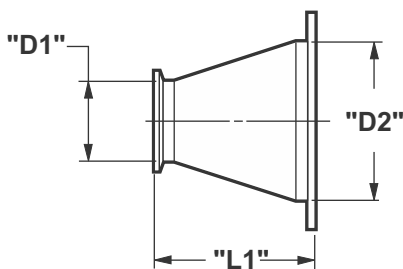

PART NO.	DESCRIPTION	"D1"	"D2"	"L1"	"D3" O.D.	"D4" DIA.
PCA32R	2" TO 3" ANGLE RING	2" (50.8)	3" (76.2)	4.25" (107.9)	5.06" (128.5)	4.31" (109.5)
PCA42R	2" TO 4" ANGLE RING	2" (50.8)	4" (101.6)	3.88" (98.6)	6.06" (153.9)	5.31" (134.9)
PCA43R	3" TO 4" ANGLE RING	3" (76.2)	4" (101.6)	4.25" (107.9)	6.06" (153.9)	5.31" (134.9)

All fittings with standard Fab-Tech connections include gaskets and clamps or hardware as required for installation.

EZ End Cap

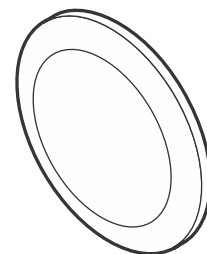
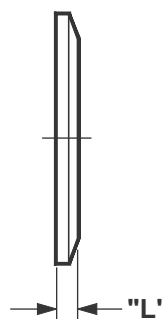
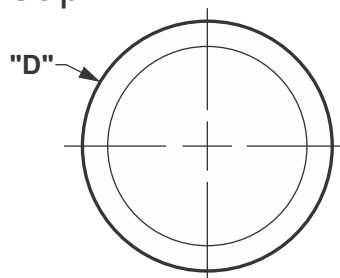

PART NO.	DESCRIPTION	"D"	"L"
PZC02	2" END CAP	2" (50.8)	0.21" (5.33)
PZC03	3" END CAP	3" (76.2)	0.21" (5.33)

All fittings with standard Fab-Tech connections include gaskets and clamps or hardware as required for installation.

METRIC EQUIVALENTS ARE SHOWN IN PARENTHESIS & ITALICS (MILLIMETERS OR AS NOTED)

Micro-Adjustable EZ Damper

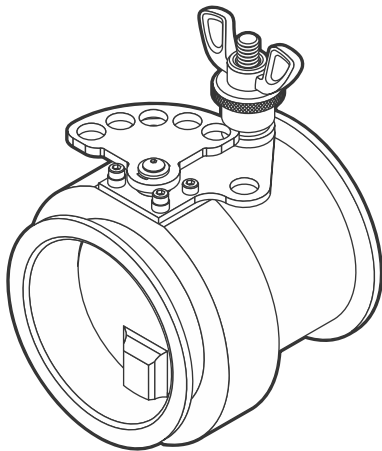

PART NO.	DESCRIPTION	"D"	"L"
PZD02	2" EZ-DAMPER	2" (50.8)	3.875" (98.4)
PZD03	3" EZ-DAMPER	3" (76.2)	3.875" (98.4)

All fittings with standard Fab-Tech connections include gaskets and clamps or hardware as required for installation.

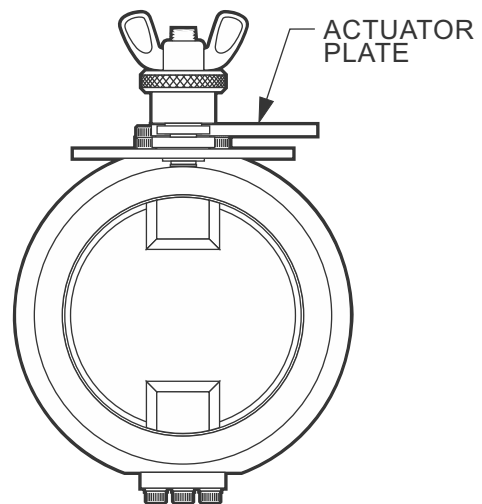
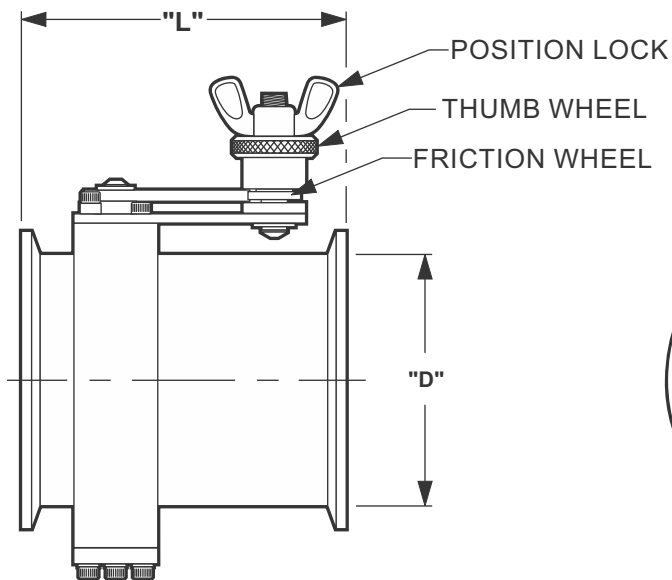
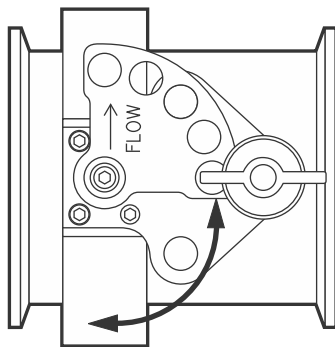

METRIC EQUIVALENTS ARE SHOWN IN PARENTHESIS & ITALICS (MILLIMETERS OR AS NOTED)

Field Installed Straight Duct EZ Flange

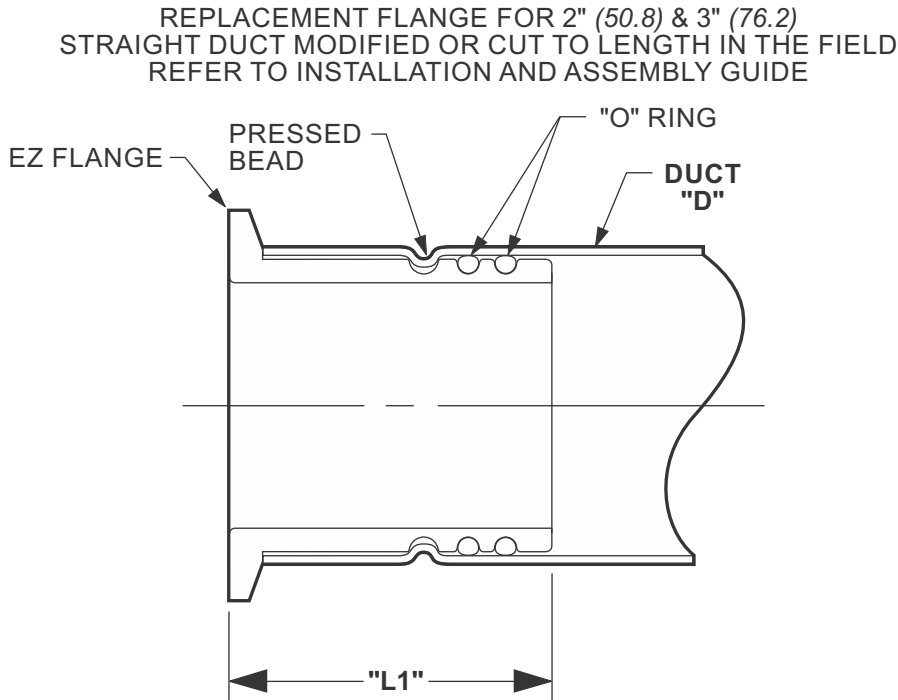

PART NO.	DESCRIPTION	"D"	"L1"
HTB02	2" FIELD FLANGE	2" (50.8)	2" (50.8)
HTB03	3" FIELD FLANGE	3" (76.2)	2" (50.8)

**FOR USE ON EZ STRAIGHT DUCT ONLY
 NOT DESIGNED FOR EZ ELBOWS, TEES, OR REDUCERS**

NOTES:

1. REQUIRES PURCHASE OF PRESSING WHEEL, PART #D0700 FOR INSTALLATION. THE PRESSING WHEEL IS USED TO PRESS A BEAD AROUND THE DUCT TO COMPLETE THE INSTALLATION. WHEEL FITS RIDGID PIPE CUTTER MODEL 3S. REFER TO FAB-TECH'S **INSTALLATION AND INSTALLATION GUIDE** FOR ASSEMBLY INSTRUCTIONS.
2. PERMASHIELD FLUOROPOLYMER BARRIER COATING ON INTERIOR AND EXTERIOR SURFACES.
3. ALL DUCT FITTINGS WITH STANDARD FAB-TECH CONNECTIONS INCLUDE GASKETS AND CLAMPS OR HARDWARE AS REQUIRED FOR INSTALLATION.

METRIC EQUIVALENTS ARE SHOWN IN PARENTHESIS & ITALICS (MILLIMETERS OR AS NOTED)

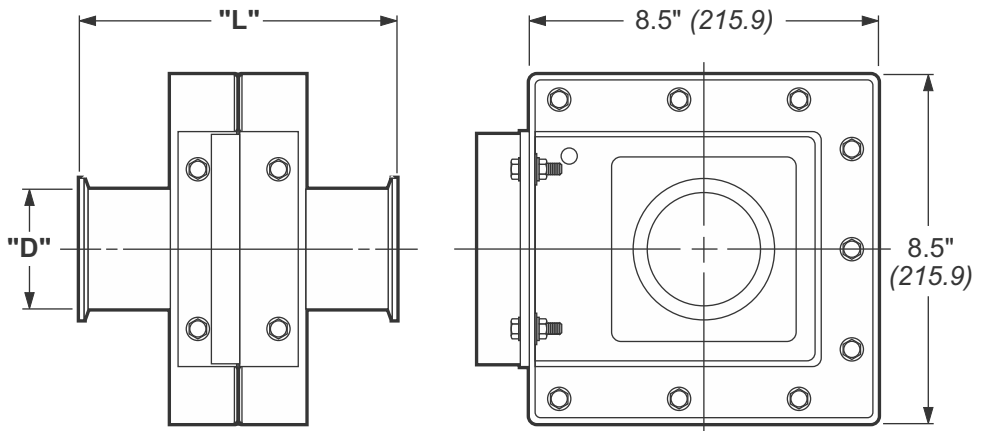
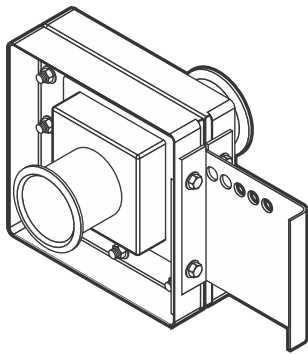

PART NO.	DESCRIPTION	"D"	"L"
PZB02H	2" EZ-BLASTGATE HORIZONTAL	2" (50.8)	8.000" (203.2)
PZB03H	3" EZ-BLASTGATE HORIZONTAL	3" (76.2)	8.000" (203.2)

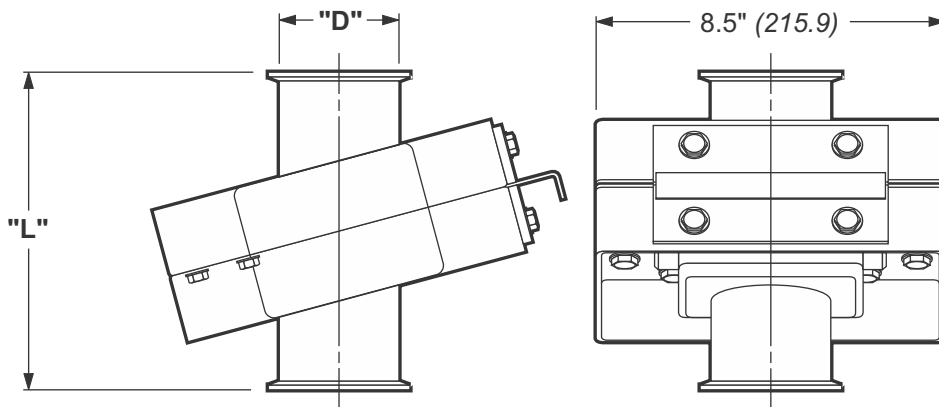

PART NO.	DESCRIPTION	"D"	"L"
PZB02V	2" EZ-BLASTGATE VERTICAL	2" (50.8)	8.000" (203.2)
PZB03V	3" EZ-BLASTGATE VERTICAL	3" (76.2)	8.000" (203.2)

NOTES:

1. STAINLESS STEEL FRAME MATERIAL, BLADE LOCKOUT SYSTEM
2. PERMASHIELD FLUOROPOLYMER BARRIER COATING ON FLANGE FACES AND INTERIOR SURFACES.
3. ALL DUCT FITTINGS WITH STANDARD FAB-TECH CONNECTIONS INCLUDE GASKETS AND CLAMPS OR HARDWARE AS REQUIRED FOR INSTALLATION.

METRIC EQUIVALENTS ARE SHOWN IN PARENTHESIS & ITALICS (MILLIMETERS OR AS NOTED)

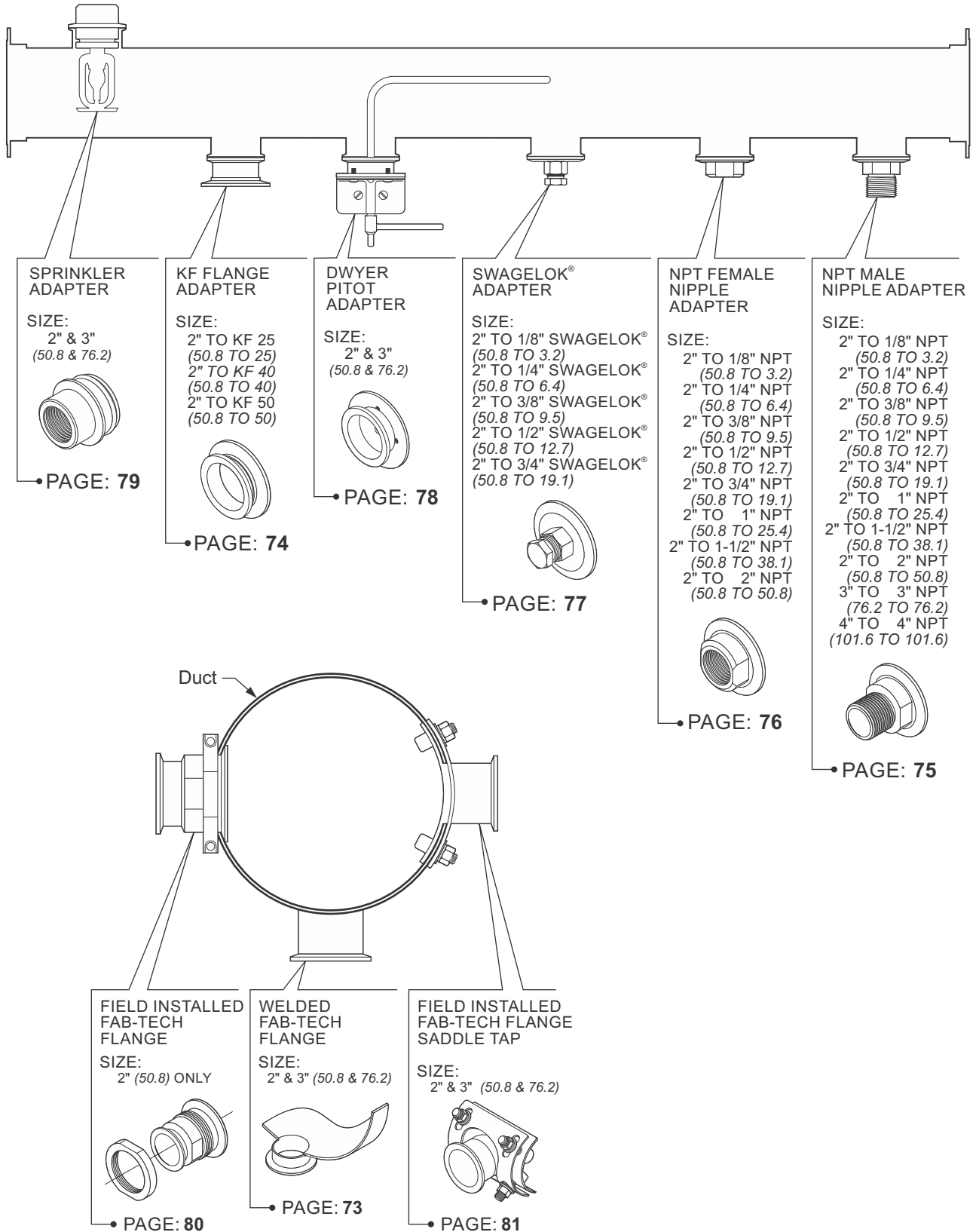

METRIC EQUIVALENTS ARE SHOWN IN PARENTHESIS & ITALICS (MILLIMETERS OR AS NOTED)

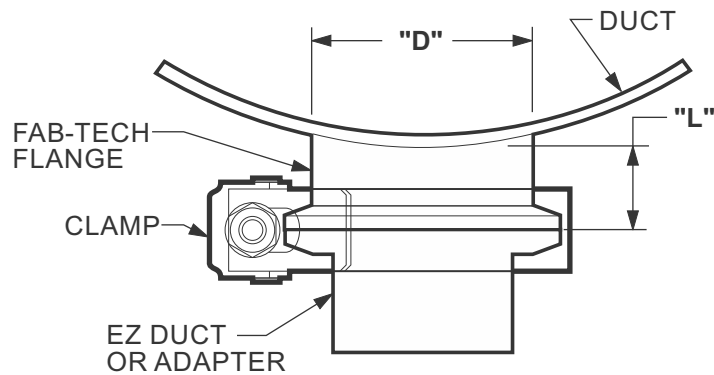
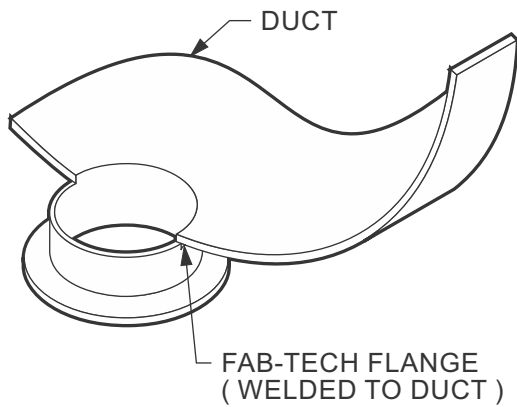

PART NO.	DESCRIPTION	"D"	"L"
FTFL2	2" FT FLANGE	2" (50.8)	.75" (19.1)
FTFL3	3" FT FLANGE	3" (76.2)	.75" (19.1)

NOTES:

1. REFER TO FAB-TECH'S INSTALLATION AND ASSEMBLY GUIDE FOR ASSEMBLY INSTRUCTIONS.
2. PERMASHIELD FLUOROPOLYMER BARRIER COATING ON INSIDE SURFACE AND FLANGE FACES.
3. FAB-TECH FLANGE / TEST PORT MAY BE INSTALLED ON FITTINGS OTHER THAN STRAIGHT DUCT.
4. REFER TO THE EZ FITTINGS SECTION FOR DUCT OR THE FAB-TECH FLANGE SYSTEM SECTION FOR ADAPTERS TO ATTACH TO THE FAB-TECH FLANGE.
5. ALL DUCT FITTINGS WITH STANDARD FAB-TECH CONNECTIONS INCLUDE GASKETS AND CLAMPS OR HARDWARE AS REQUIRED FOR INSTALLATION.

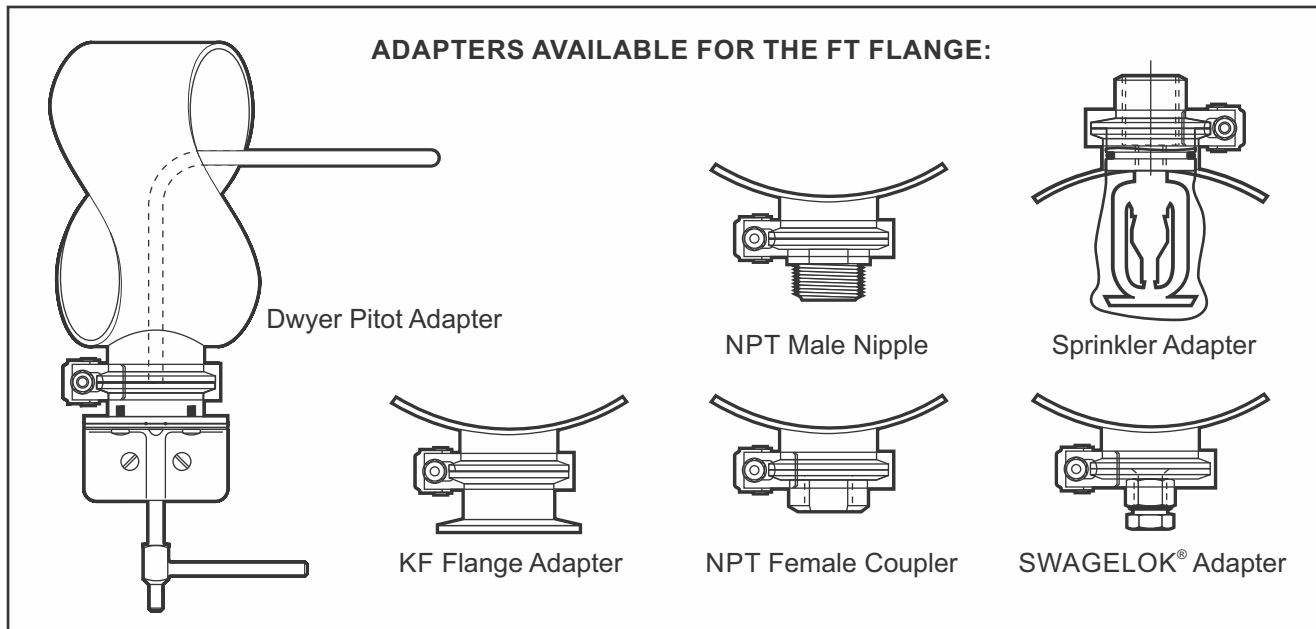

METRIC EQUIVALENTS ARE SHOWN IN PARENTHESIS & ITALICS (MILLIMETERS OR AS NOTED)

KF Flange Adapter

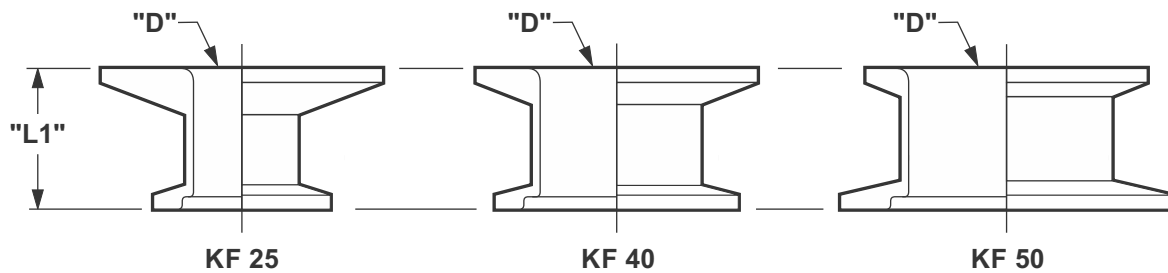
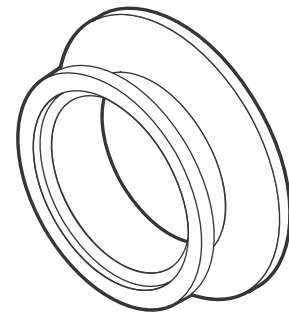

PART NO.	DESCRIPTION	KF	"D"	"L1"
FTK25	2" TO 25 KF FLANGE	25mm	2" (50.8)	1.25" (31.8)
FTK40	2" TO 40 KF FLANGE	40mm	2" (50.8)	1.25" (31.8)
FTK50	2" TO 50 KF FLANGE	50mm	2" (50.8)	1.25" (31.8)

NOTES:

1. REFER TO FAB-TECH'S **INSTALLATION AND ASSEMBLY GUIDE** FOR ASSEMBLY INSTRUCTIONS.
2. PERMASHIELD FLUOROPOLYMER BARRIER COATING ON INSIDE SURFACE AND FLANGE FACES.
3. KF ADAPTERS ARE ONLY AVAILABLE FOR 2" (50.8) FAB-TECH FLANGE CONNECTION.
4. ALL DUCT FITTINGS WITH STANDARD FAB-TECH CONNECTIONS INCLUDE GASKETS AND CLAMPS OR HARDWARE AS REQUIRED FOR INSTALLATION.

METRIC EQUIVALENTS ARE SHOWN IN PARENTHESIS & ITALICS (MILLIMETERS OR AS NOTED)

NPT Male Nipple Adapter

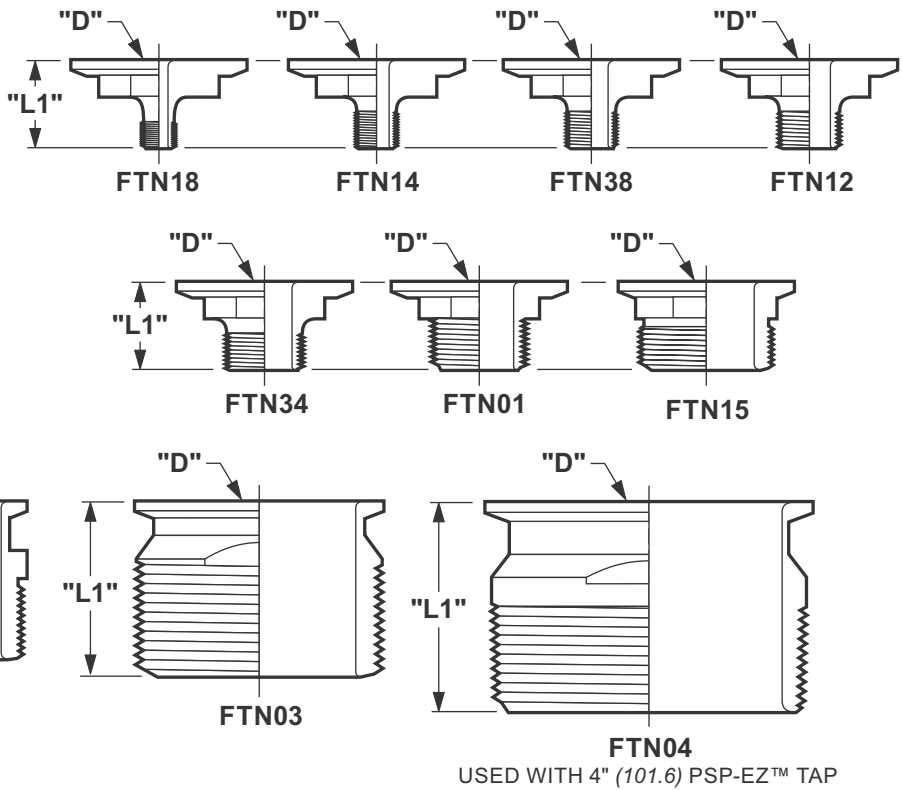
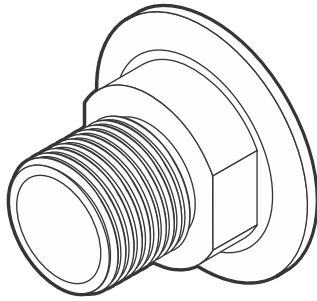

PART NO.	DESCRIPTION	"D"	PIPE THREAD	"L1"
FTN18	2" TO 1/8" NPT	2" (50.8)	1/8" (3.2) NPT	1.25" (31.8)
FTN14	2" TO 1/4" NPT	2" (50.8)	1/4" (6.4) NPT	1.25" (31.8)
FTN38	2" TO 3/8" NPT	2" (50.8)	3/8" (9.5) NPT	1.25" (31.8)
FTN12	2" TO 1/2" NPT	2" (50.8)	1/2" (12.7) NPT	1.25" (31.8)
FTN34	2" TO 3/4" NPT	2" (50.8)	3/4" (19.1) NPT	1.25" (31.8)
FTN01	2" TO 1" NPT	2" (50.8)	1" (25.4) NPT	1.25" (31.8)
FTN15	2" TO 1.5" NPT	2" (50.8)	1.5" (38.1) NPT	1.25" (31.8)
FTN02	2" TO 2" NPT	2" (50.8)	2" (50.8) NPT	2.25" (57.2)
FTN03	3" TO 3" NPT	3" (76.2)	3" (76.2) NPT	2.50" (63.5)
FTN04**	4" TO 4" NPT	4" (101.6)	4" (101.6) NPT	3.00" (76.2)

**USED WITH 4" (101.6) PSP-EZ™ TAP

NOTES:

- REFER TO FAB-TECH'S **INSTALLATION AND ASSEMBLY GUIDE** FOR ASSEMBLY INSTRUCTIONS.
- PERMASHIELD FLUOROPOLYMER BARRIER COATING ON INSIDE SURFACE AND FLANGE FACE.
- NPT NIPPLES ARE NOT COVERED UNDER WARRANTY OTHER THAN FOR DEFECTS IN MANUFACTURE. NPT THREADS ARE NOT COATED AND SINCE THE THREADS COULD POSSIBLY COME IN CONTACT WITH CORROSIVE FUMES AND FLUIDS, FAB-TECH OFFERS ONLY A LIMITED WARRANTY FOR THESE PARTS. DEPENDING ON THE SPECIFIC APPLICATION, NPT ADAPTERS SHOULD FALL INTO THE CLASSIFICATION OF CONSUMABLE PARTS.
- ALL DUCT FITTINGS WITH STANDARD FAB-TECH CONNECTIONS INCLUDE GASKETS AND CLAMPS OR HARDWARE AS REQUIRED FOR INSTALLATION.

METRIC EQUIVALENTS ARE SHOWN IN PARENTHESIS & ITALICS (MILLIMETERS OR AS NOTED)

NPT Female Coupler Adapter

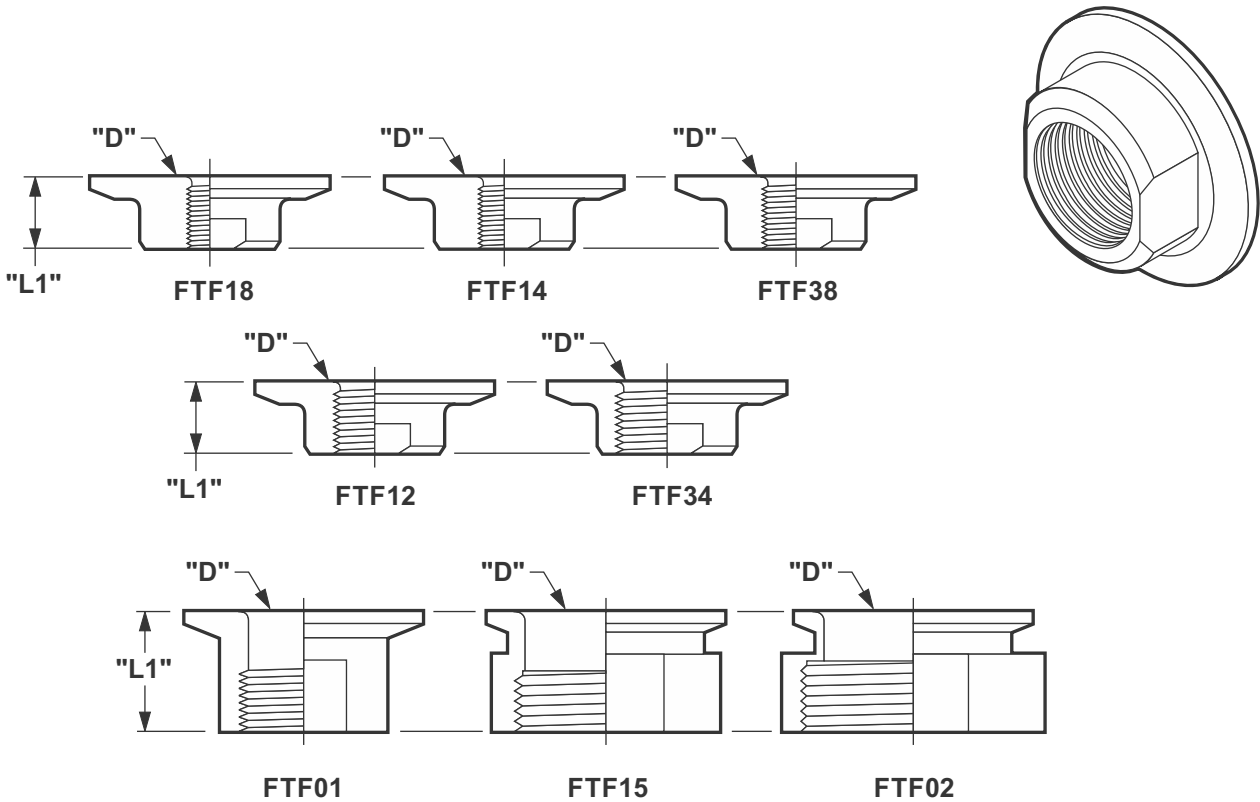

PART NO.	DESCRIPTION	"D"	PIPE THREAD	"L1"
FTF18	2" TO 1/8" NPT	2" (50.8)	1/8" (3.2) NPT	.75" (19.1)
FTF14	2" TO 1/4" NPT	2" (50.8)	1/4" (6.4) NPT	.75" (19.1)
FTF38	2" TO 3/8" NPT	2" (50.8)	3/8" (9.5) NPT	.75" (19.1)
FTF12	2" TO 1/2" NPT	2" (50.8)	1/2" (12.7) NPT	.75" (19.1)
FTF34	2" TO 3/4" NPT	2" (50.8)	3/4" (19.1) NPT	.75" (19.1)
FTF01	2" TO 1" NPT	2" (50.8)	1" (25.4) NPT	1.25" (31.8)
FTF15	2" TO 1.5" NPT	2" (50.8)	1.5" (38.1) NPT	1.25" (31.8)
FTF02	2" TO 2" NPT	2" (50.8)	2" (50.8) NPT	1.25" (31.8)

NOTES:

1. REFER TO FAB-TECH'S **INSTALLATION AND ASSEMBLY GUIDE** FOR ASSEMBLY INSTRUCTIONS.
2. PERMASHIELD FLUOROPOLYMER BARRIER COATING ON FLANGE FACE.
3. NPT NIPPLES ARE NOT COVERED UNDER WARRANTY OTHER THAN FOR DEFECTS IN MANUFACTURE. NPT THREADS ARE NOT COATED AND SINCE THE THREADS COULD POSSIBLY COME IN CONTACT WITH CORROSIVE FUMES AND FLUIDS, FAB-TECH OFFERS ONLY A LIMITED WARRANTY FOR THESE PARTS. DEPENDING ON THE SPECIFIC APPLICATION, NPT ADAPTERS SHOULD FALL INTO THE CLASSIFICATION OF CONSUMABLE PARTS.
4. ALL DUCT FITTINGS WITH STANDARD FAB-TECH CONNECTIONS INCLUDE GASKETS AND CLAMPS OR HARDWARE AS REQUIRED FOR INSTALLATION.

METRIC EQUIVALENTS ARE SHOWN IN PARENTHESIS & ITALICS (MILLIMETERS OR AS NOTED)

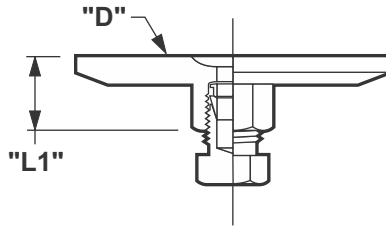
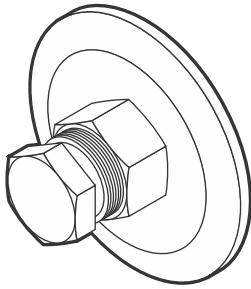

FTS14

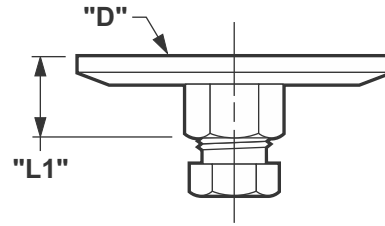

FTS38

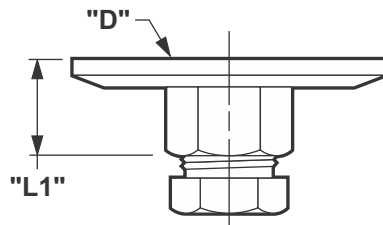

FTS12

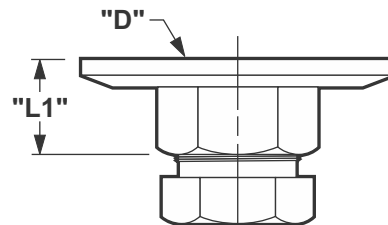

FTS34

PART NO.	DESCRIPTION	"D"	THREAD	"L1"
FTS18**	2" TO 1/8" (3.2) SWAGELOK®	2" (50.8)		
FTS14	2" TO 1/4" (6.4) SWAGELOK®	2" (50.8)	7/16-20	.59" (14.99)
FTS38	2" TO 3/8" (9.5) SWAGELOK®	2" (50.8)	9/16-18	.65" (10.73)
FTS12	2" TO 1/2" (12.7) SWAGELOK®	2" (50.8)	3/4-16	.77" (19.56)
FTS34	2" TO 3/4" (19.1) SWAGELOK®	2" (50.8)	1-1/16-12	.77" (19.56)

**FTS18 IS AVAILABLE AS A CUSTOM ADAPTER, NOT A STOCK ITEM

NOTES:

1. REFER TO FAB-TECH'S **INSTALLATION AND ASSEMBLY GUIDE** FOR ASSEMBLY INSTRUCTIONS.
2. PERMASHIELD FLUOROPOLYMER BARRIER COATING ON INSIDE SURFACE AND FLANGE FACE.
3. SWAGELOK ADAPTERS ARE NOT COVERED UNDER WARRANTY OTHER THAN FOR DEFECTS IN MANUFACTURE. SWAGELOK THREADS ARE NOT COATED AND SINCE THE THREADS COULD POSSIBLY COME IN DIRECT CONTACT WITH CORROSIVE FUMES AND FLUIDS, FAB-TECH OFFERS ONLY A LIMITED WARRANTY FOR THESE PARTS. DEPENDING ON THE SPECIFIC APPLICATION, SWAGELOK ADAPTERS SHOULD FALL INTO THE CLASSIFICATION OF CONSUMABLE PARTS.
4. ALL DUCT FITTINGS WITH STANDARD FAB-TECH CONNECTIONS INCLUDE GASKETS AND CLAMPS OR HARDWARE AS REQUIRED FOR INSTALLATION.

METRIC EQUIVALENTS ARE SHOWN IN PARENTHESIS & ITALICS (MILLIMETERS OR AS NOTED)

Dwyer Pitot Adapter

PART NO.	DESCRIPTION	"D"	"L1"
FTPT2	2" PITOT FLANGE	2" (50.8)	0.88" (22.4)
FTPT3	3" PITOT FLANGE	3" (76.2)	0.88" (22.4)

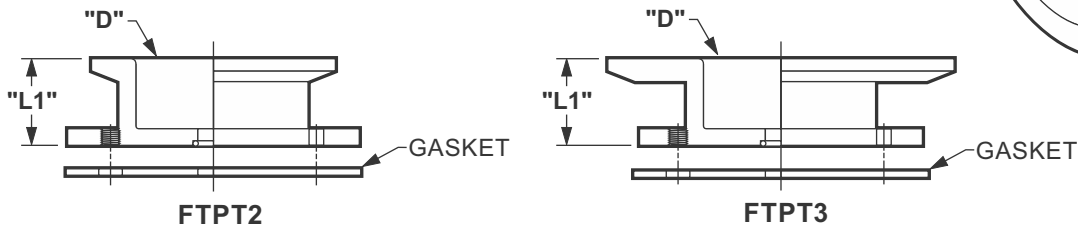
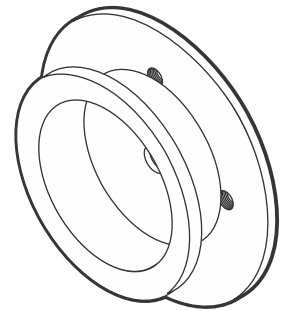

NOTES:

1. REFER TO FAB-TECH'S **INSTALLATION AND ASSEMBLY GUIDE** FOR ASSEMBLY INSTRUCTIONS.
2. PERMASHIELD FLUOROPOLYMER BARRIER COATING ON INSIDE SURFACE AND FLANGE FACES.
3. ALL DUCT FITTINGS WITH STANDARD FAB-TECH CONNECTIONS INCLUDE GASKETS AND CLAMPS OR HARDWARE AS REQUIRED FOR INSTALLATION.

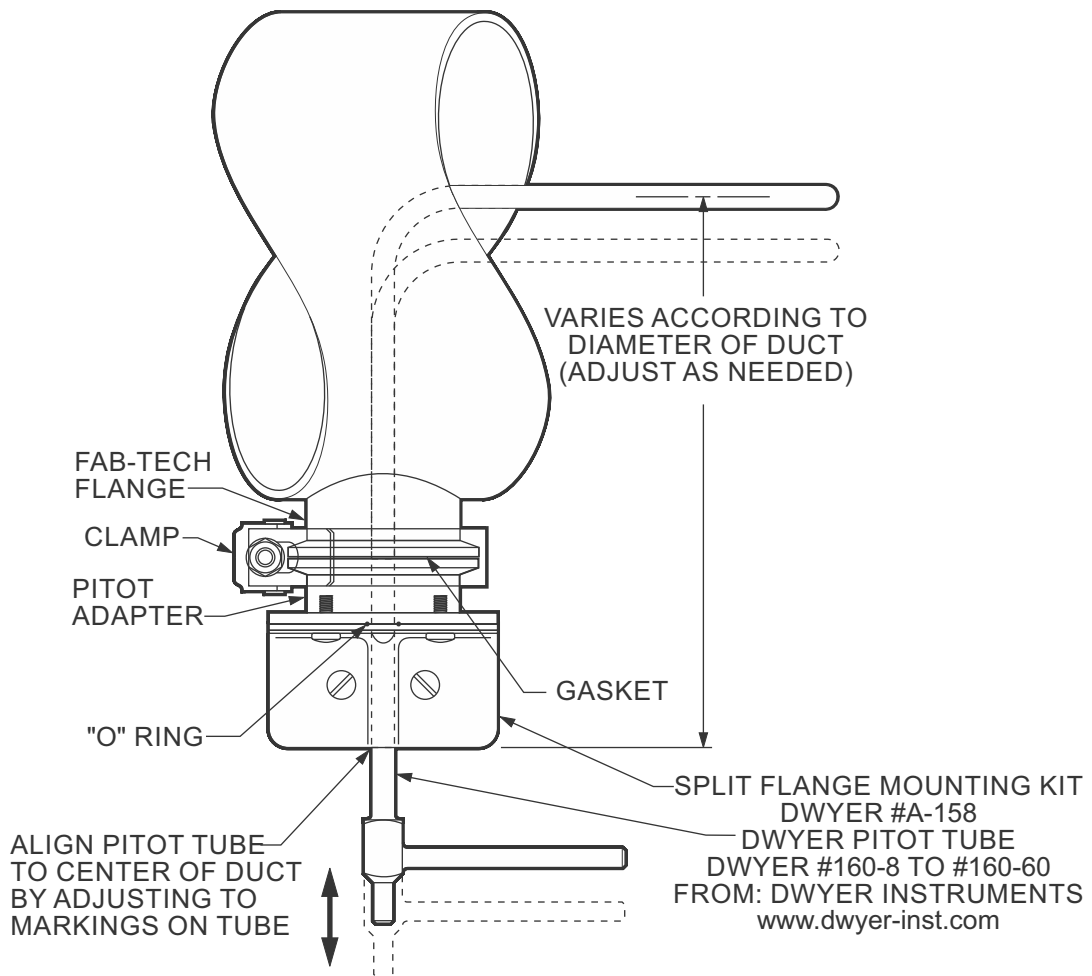

METRIC EQUIVALENTS ARE SHOWN IN PARENTHESIS & ITALICS (MILLIMETERS OR AS NOTED)

Sprinkler Adapter

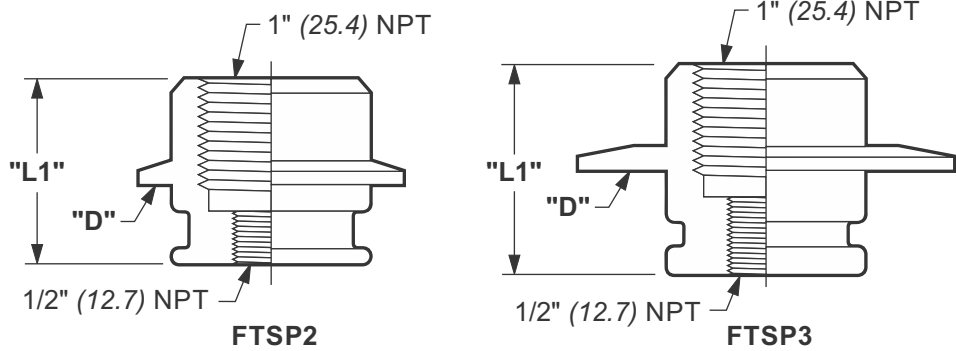
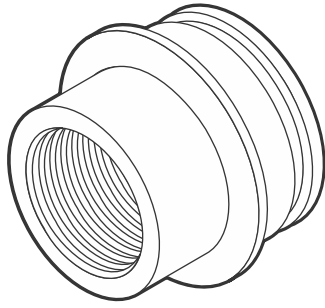

PART NO.	DESCRIPTION	"D"	"L1"
FTSP2	2" SPRINKLER FLANGE	2" (50.8)	1.10" (27.9)
FTSP3	3" SPRINKLER FLANGE	3" (76.2)	2.00" (50.8)

NOTES:

1. REFER TO FAB-TECH'S **INSTALLATION AND ASSEMBLY GUIDE** FOR ASSEMBLY INSTRUCTIONS.
2. PERMASHIELD FLUOROPOLYMER BARRIER COATING ON FLANGE FACE AND O-RING SURFACES.
3. ALL DUCT FITTINGS WITH STANDARD FAB-TECH CONNECTIONS INCLUDE GASKETS AND CLAMPS OR HARDWARE AS REQUIRED FOR INSTALLATION.

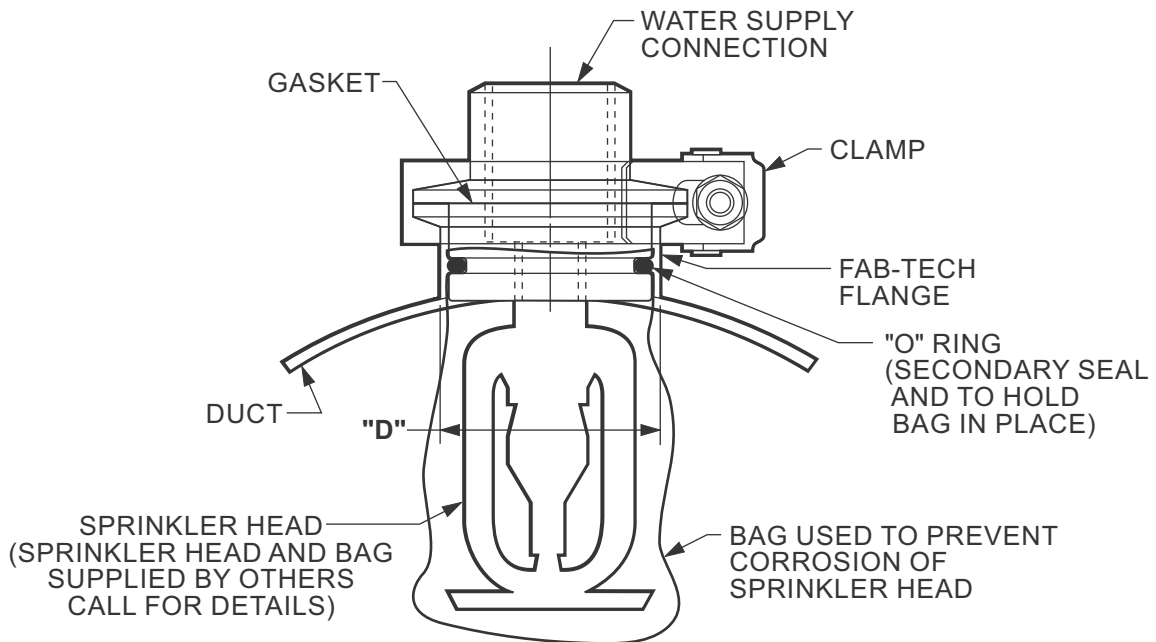

METRIC EQUIVALENTS ARE SHOWN IN PARENTHESIS & ITALICS (MILLIMETERS OR AS NOTED)

Field Installed 2" (50.8) Fab-Tech Flange

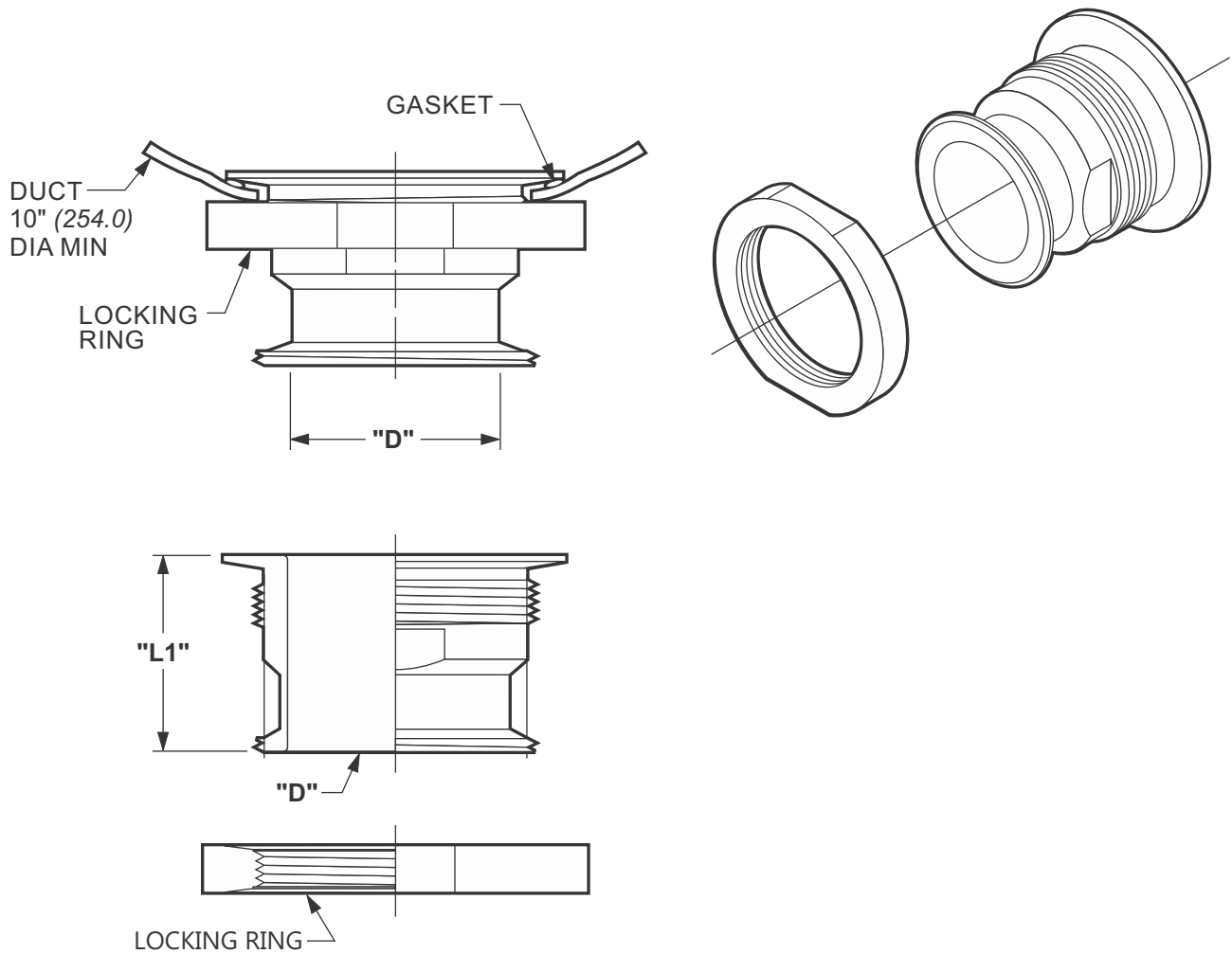

PART NO.	DESCRIPTION	"D"	"L1"	HOST DUCT DIAMETER
FTFL2FI	2" (50.8) FIELD FLANGE	2" (50.8)	1.69" (42.9)	10" (254.0) DIAMETER MINIMUM

NOTES:

1. REFER TO FAB-TECH'S **INSTALLATION AND ASSEMBLY GUIDE** FOR ASSEMBLY INSTRUCTIONS.
2. PERMASHIELD FLUOROPOLYMER BARRIER COATING ON INSIDE SURFACE AND FLANGE FACE.
3. REQUIRES HYDRAULIC PUNCH & SWAGE KIT (TPS02) TO INSTALL - CHECK ACCESSORIES SECTION.
4. REQUIRES DISASSEMBLY OF DUCT TO INSTALL THIS FITTINGS.
5. ALL DUCT FITTINGS WITH STANDARD FAB-TECH CONNECTIONS INCLUDE GASKETS AND CLAMPS OR HARDWARE AS REQUIRED FOR INSTALLATION.

METRIC EQUIVALENTS ARE SHOWN IN PARENTHESIS & ITALICS (MILLIMETERS OR AS NOTED)

Field Installed Fab-Tech Flange Saddle Tap

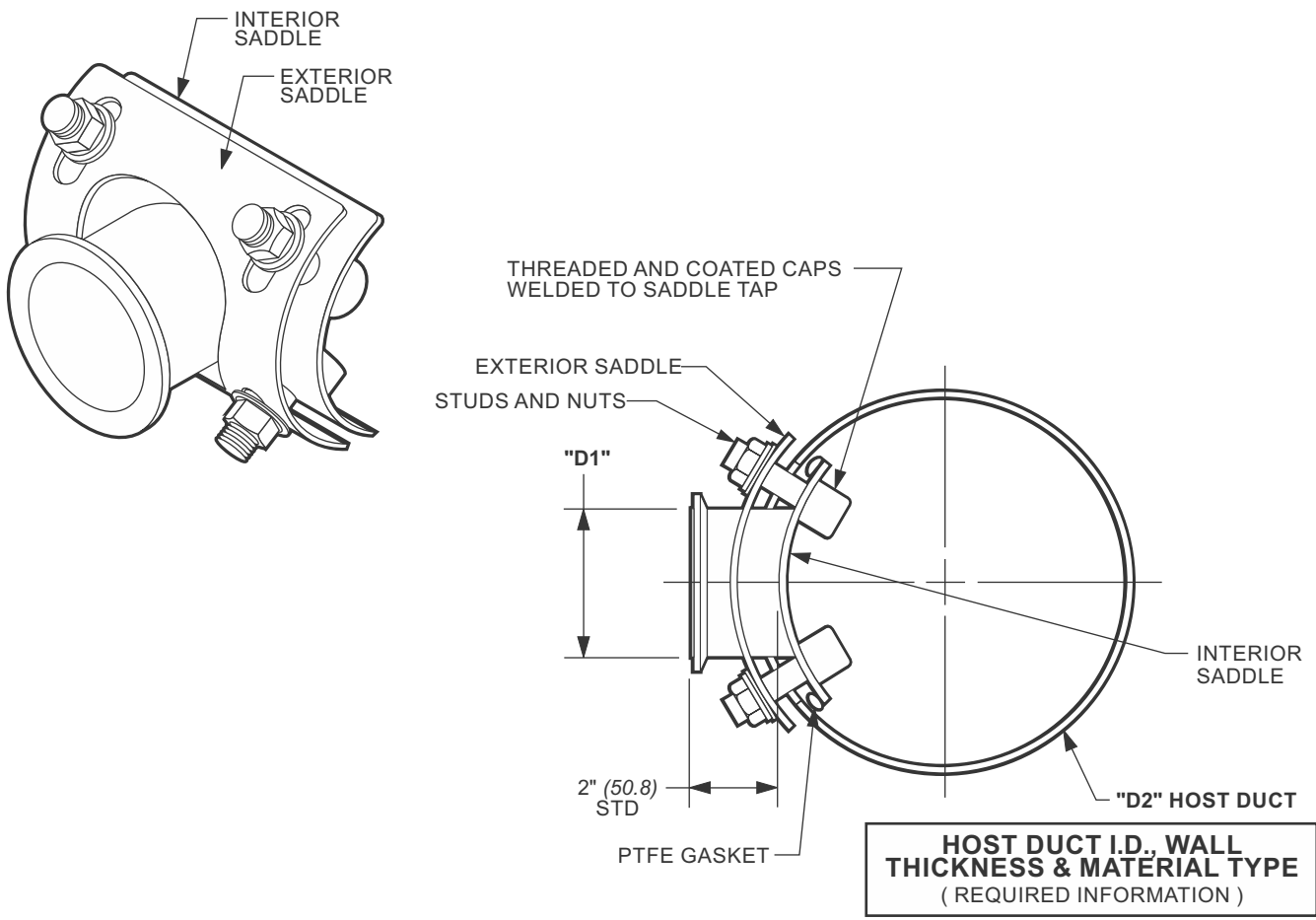

SECTION THROUGH DUCT

PART NO.	DESCRIPTION	"D1"	"D2"
PZQ02	2" EZ-TAP	2" (50.8)	6" (152.4) MIN
PZQ03	3" EZ-TAP	3" (76.2)	8" (203.2) MIN

NOTES:

1. REFER TO FAB-TECH'S **INSTALLATION AND ASSEMBLY GUIDE** FOR ASSEMBLY INSTRUCTIONS.
2. PERMASHIELD FLUOROPOLYMER BARRIER COATING ON INSIDE SURFACE AND FLANGE FACE.
3. FAB-TECH'S FIELD INSTALLED SADDLE TAP WILL ALLOW A NEW 2" DIAMETER BRANCH TO BE INSTALLED IN A 6" (152.4) AND LARGER DIAMETER DUCT OR A NEW 3" (76.2) DIAMETER BRANCH TO BE INSTALLED IN AN 8" (203.2) AND LARGER DIAMETER DUCT **WITHOUT SHUTTING DOWN THE EXHAUST SYSTEM.**
4. ALL DUCT FITTINGS WITH STANDARD FAB-TECH CONNECTIONS INCLUDE GASKETS AND CLAMPS OR HARDWARE AS REQUIRED FOR INSTALLATION.

METRIC EQUIVALENTS ARE SHOWN IN PARENTHESIS & ITALICS (MILLIMETERS OR AS NOTED)

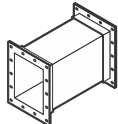
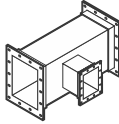
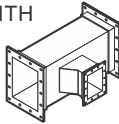
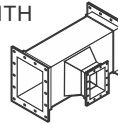
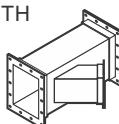
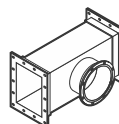
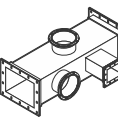
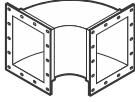
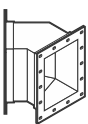
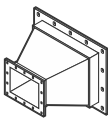
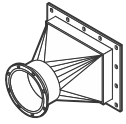
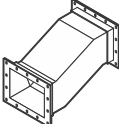
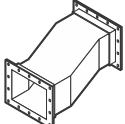
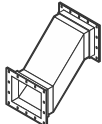
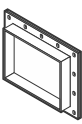
<p>RECTANGULAR DUCT</p>	<p>STRAIGHT DUCT</p>  <p>• PAGE: 84</p>	<p>STRAIGHT DUCT WITH STRAIGHT RECTANGULAR TAP</p>  <p>• PAGE: 84</p>
<p>STRAIGHT DUCT WITH RECTANGULAR BOOT TAP</p>  <p>• PAGE: 85</p>	<p>STRAIGHT DUCT WITH RECTANGULAR CONICAL TAP</p>  <p>• PAGE: 85</p>	<p>STRAIGHT DUCT WITH RECTANGULAR LATERAL TAP</p>  <p>• PAGE: 86</p>
<p>STRAIGHT DUCT WITH ROUND TAP</p>  <p>• PAGE: 86</p>	<p>STRAIGHT DUCT WITH MULTIPLE TAPS</p>  <p>• PAGE: 87</p>	<p>RADIAL ELBOW 30°, 45°, 60°, 90°</p>  <p>• PAGE: 87</p>
<p>MITERED ELBOW 30°, 45°, 60°, 90°</p>  <p>• PAGE: 88</p>	<p>CONCENTRIC TRANSITION</p>  <p>• PAGE: 89</p>	<p>CONCENTRIC RECTANGULAR TO ROUND TRANSITION</p>  <p>• PAGE: 89</p>
<p>VERTICAL OFFSET</p>  <p>• PAGE: 90</p>	<p>HORIZONTAL OFFSET</p>  <p>• PAGE: 90</p>	<p>DOUBLE OFFSET</p>  <p>• PAGE: 91</p>
<p>END CAP</p>  <p>• PAGE: 91</p>		

METRIC EQUIVALENTS ARE SHOWN IN PARENTHESIS & ITALICS (MILLIMETERS OR AS NOTED)

Rectangular Mounting Flange Standards

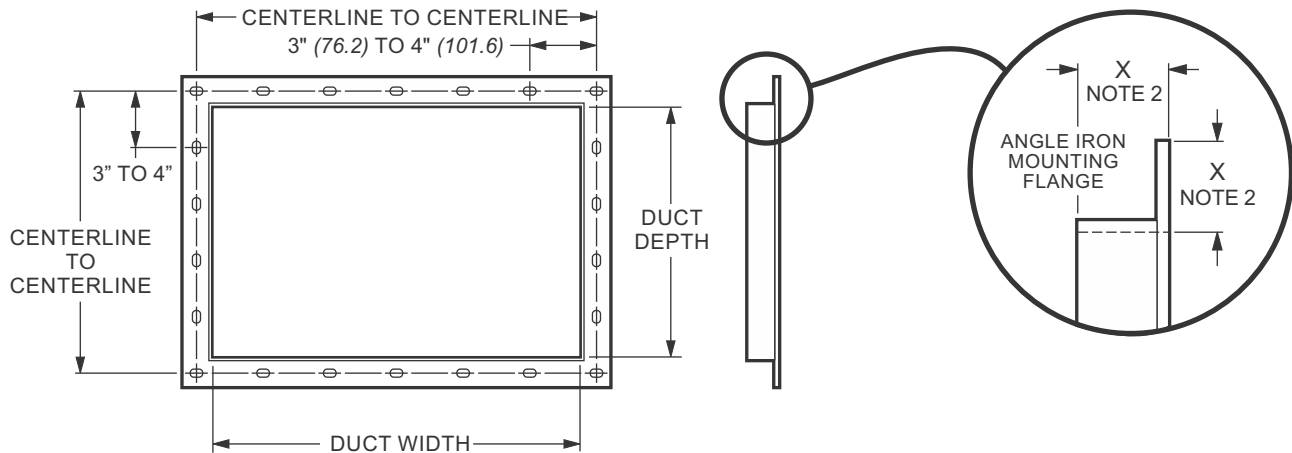

TABLE BELOW IS FOR STANDARD DUCT LENGTH OF 48-1/4" (1225.6)
S = STIFFENER ADDED

DUCT WIDTH	-6" W.G. (-1,495 Pa)		-10" W.G. (-2,491 Pa)		-14" W.G. (-3,487 Pa)		-18" W.G. (-4,484 Pa)	
	DUCT GAUGE	ANGLE SIZE	DUCT GAUGE	ANGLE SIZE	DUCT GAUGE	ANGLE SIZE	DUCT GAUGE	ANGLE SIZE
12" (304.8) - 24" (609.6)	16(1.59)	1.5" (38.1)	12(2.78)	1.5" (38.1)	12(2.78)	1.5" (38.1)	10(3.57)	2" (50.8)
26" (660.4) - 36" (914.4)	16	1.5" (38.1)	12	2" (50.8)	12	2" (50.8)	10	2" (50.8)
38" (965.2) - 48" (1219.2)	16	2" (50.8)	12	2" (50.8)	12	2" (50.8)	10	3" (76.2)
50" (1270.0) - 60" (1524.0)	16S	2" (50.8)	12S	2" (50.8)	12S	2" (50.8)	10S	2" (50.8)
62" (1574.8) - 72" (1828.8)	16S	2" (50.8)	12S	2" (50.8)	12S	2" (50.8)	10S	2" (50.8)
74" (1879.6) - 84" (2133.6)	16S	2" (50.8)	12S	2" (50.8)	12S	2" (50.8)	10S	2.5" (63.5)
86" (2184.4) - 96" (2438.4)	16S	2" (50.8)	12S	2" (50.8)	12S	2.5" (63.5)	10S	3" (76.2)

NOTES:

1. REFER TO FAB-TECH'S **INSTALLATION AND ASSEMBLY GUIDE** FOR ASSEMBLY INSTRUCTIONS.
2. ANGLE SIZES (X): 1.5" (38.1), 2" (50.8), 2.5" (63.5), AND 3.0" (76.2)
3. ANGLE THICKNESS FOR ALL SIZES: 3/16" (4.76)
4. FLANGE ANGLE SIZE DETERMINED FROM DUCT WIDTH AND SYSTEM PRESSURE.
5. FLANGE MATERIAL IS STAINLESS STEEL.
6. PERMASHIELD FLUOROPOLYMER BARRIER COATING ON INSIDE SURFACE AND FLANGE FACES.
7. THE NUMBER OF HOLES FOR THE BOLT PATTERN IS DETERMINED FROM THE DUCT WIDTH AND DEPTH. HOLE TO HOLE DISTANCE WILL BE CALCULATED TO BE BETWEEN 3" (76.2) TO 4" (101.6). OBLONG HOLES ARE PUNCHED ALONG THE FRAME CENTERLINE.
8. DUCT WIDTH OR DEPTH OF 98" (2489.2) AND LARGER REQUIRES ENGINEERING REVIEW.
9. INTERIOR STIFFENERS (1" SCH40 PIPE) ARE WELDED BETWEEN DUCT SIDES 50" (1270.0) WIDE OR GREATER. SEPARATE OFFSET STIFFENERS ARE USED WHEN BOTH DUCT WIDTH AND DEPTH ARE 50" (1270.0) OR GREATER.
10. ALL DUCT FITTINGS WITH STANDARD FAB-TECH CONNECTIONS INCLUDE GASKETS AND CLAMPS OR HARDWARE AS REQUIRED FOR INSTALLATION.

METRIC EQUIVALENTS ARE SHOWN IN PARENTHESIS & ITALICS (MILLIMETERS OR AS NOTED)

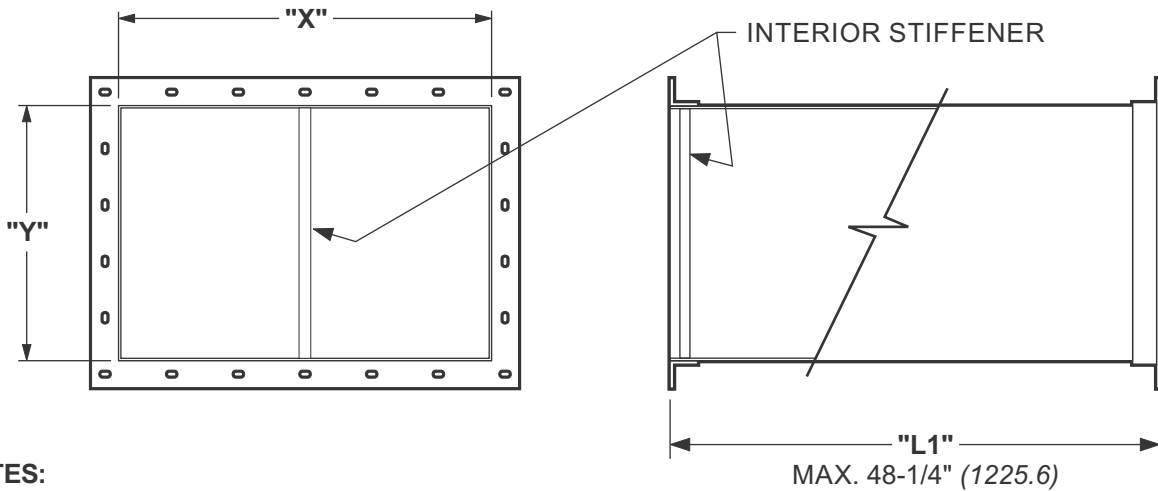

NOTES:

1. **1** **OPTION:** CUSTOM LENGTH
2. **2** **OPTION:** RAW END
3. INTERIOR STIFFENERS (1" SCH40 PIPE) ARE WELDED BETWEEN THE OPPOSITE MIDPOINTS OF THE DUCT FLANGE FOR DUCT WIDTH OR DEPTH OF 50" (1270.0) WIDE OR GREATER.
4. DUCT WIDTH OR DEPTH OF 98" (2489.2) AND LARGER REQUIRES ENGINEERING REVIEW.
5. GREATER THAN STANDARD DUCT LENGTHS AND/OR HIGHER SYSTEM PRESSURES MAY REQUIRE ADDITIONAL STIFFENERS PER SMACNA, CONTACT FAB-TECH FOR SPECIFIC GUIDELINES.
6. ALL DUCT FITTINGS WITH STANDARD FAB-TECH CONNECTIONS INCLUDE GASKETS AND CLAMPS OR HARDWARE AS REQUIRED FOR INSTALLATION.

Straight Duct with Straight Rectangular Tap

NOTES:

1. **1** **OPTION:** CUSTOM LENGTH
2. **2** **OPTION:** RAW END
3. INTERIOR STIFFENERS (1" SCH40 PIPE) ARE WELDED BETWEEN THE OPPOSITE MIDPOINTS OF THE DUCT FLANGE FOR DUCT WIDTH OR DEPTH OF 50" (1270.0) WIDE OR GREATER.
4. DUCT WIDTH OR DEPTH OF 98" (2489.2) AND LARGER REQUIRES ENGINEERING REVIEW.
5. GREATER THAN STANDARD DUCT LENGTHS AND/OR HIGHER SYSTEM PRESSURES MAY REQUIRE ADDITIONAL STIFFENERS PER SMACNA, CONTACT FAB-TECH FOR SPECIFIC GUIDELINES.
6. ALL DUCT FITTINGS WITH STANDARD FAB-TECH CONNECTIONS INCLUDE GASKETS AND CLAMPS OR HARDWARE AS REQUIRED FOR INSTALLATION.

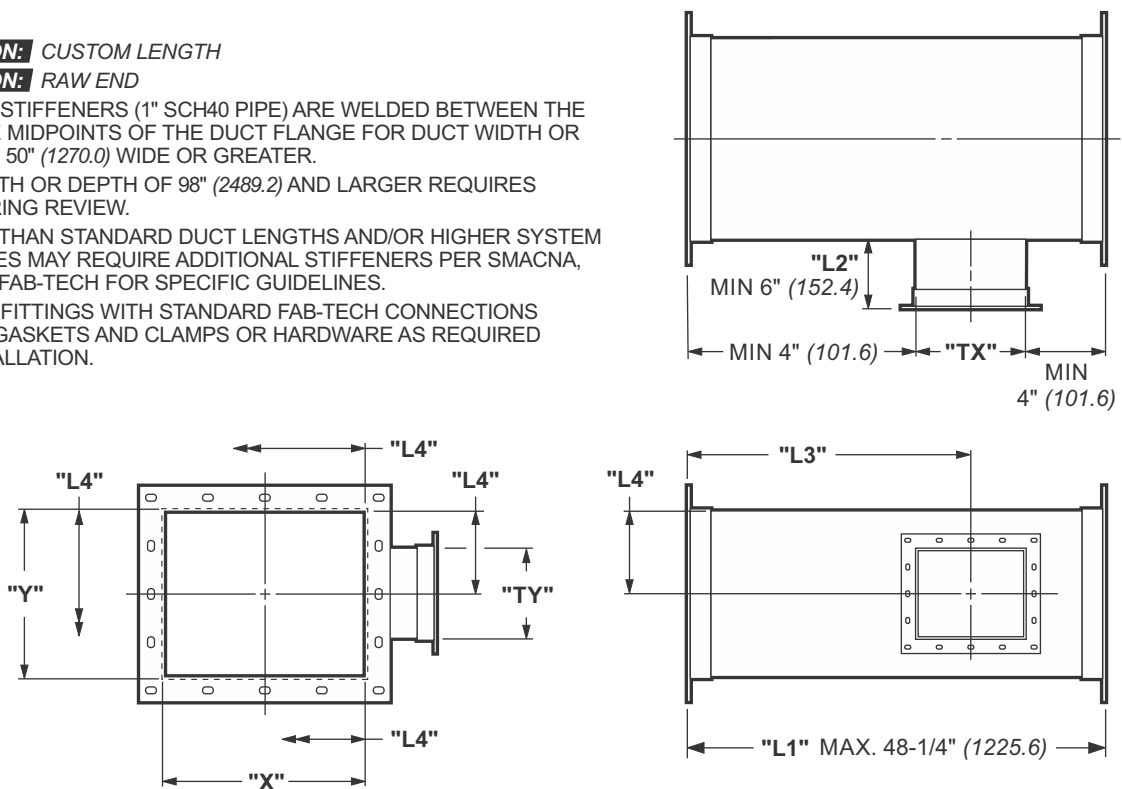

METRIC EQUIVALENTS ARE SHOWN IN PARENTHESIS & ITALICS (MILLIMETERS OR AS NOTED)

Straight Duct with Rectangular Boot Tap

NOTES:

1. **1** **OPTION:** CUSTOM LENGTH
2. **2** **OPTION:** RAW END
3. INTERIOR STIFFENERS (1" SCH40 PIPE) ARE WELDED BETWEEN THE OPPOSITE MIDPOINTS OF THE DUCT FLANGE FOR DUCT WIDTH OR DEPTH OF 50" (1270.0) WIDE OR GREATER.
4. DUCT WIDTH OR DEPTH OF 98" (2489.2) AND LARGER REQUIRES ENGINEERING REVIEW.
5. GREATER THAN STANDARD DUCT LENGTHS AND/OR HIGHER SYSTEM PRESSURES MAY REQUIRE ADDITIONAL STIFFENERS PER SMACNA, CONTACT FAB-TECH FOR SPECIFIC GUIDELINES.
6. ALL DUCT FITTINGS WITH STANDARD FAB-TECH CONNECTIONS INCLUDE GASKETS AND CLAMPS OR HARDWARE AS REQUIRED FOR INSTALLATION.

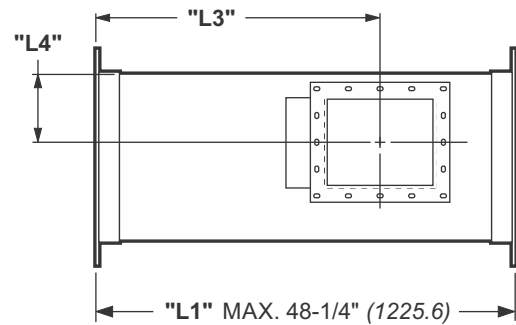
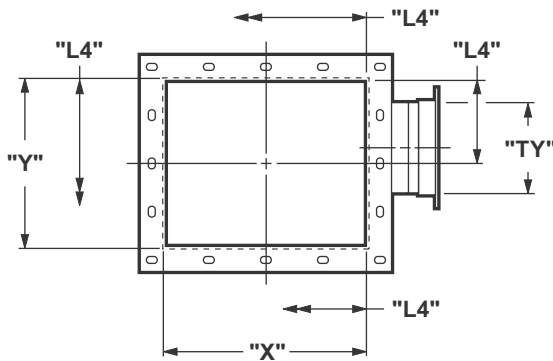
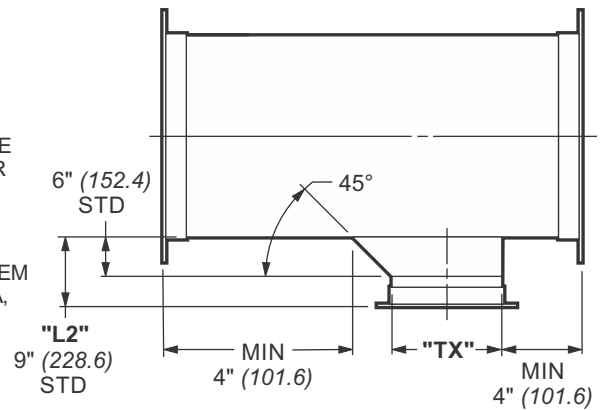

Straight Duct with Rectangular Conical Tap

NOTES:

1. **1** **OPTION:** CUSTOM LENGTH
2. **2** **OPTION:** RAW END
3. INTERIOR STIFFENERS (1" SCH40 PIPE) ARE WELDED BETWEEN THE OPPOSITE MIDPOINTS OF THE DUCT FLANGE FOR DUCT WIDTH OR DEPTH OF 50" (1270.0) WIDE OR GREATER.
4. DUCT WIDTH OR DEPTH OF 98" (2489.2) AND LARGER REQUIRES ENGINEERING REVIEW.
5. GREATER THAN STANDARD DUCT LENGTHS AND/OR HIGHER SYSTEM PRESSURES MAY REQUIRE ADDITIONAL STIFFENERS PER SMACNA, CONTACT FAB-TECH FOR SPECIFIC GUIDELINES.
6. ALL DUCT FITTINGS WITH STANDARD FAB-TECH CONNECTIONS INCLUDE GASKETS AND CLAMPS OR HARDWARE AS REQUIRED FOR INSTALLATION.

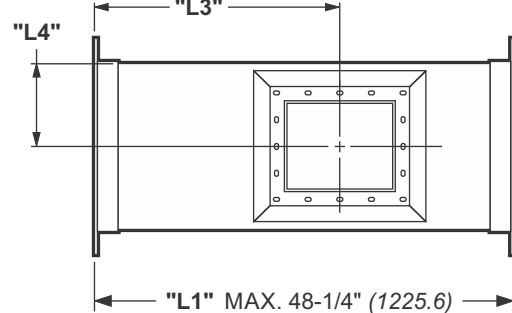
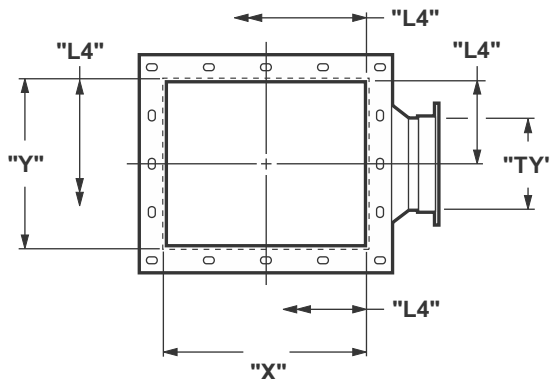
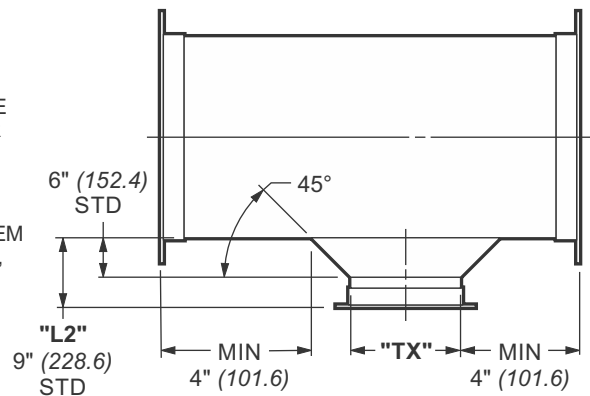

METRIC EQUIVALENTS ARE SHOWN IN PARENTHESIS & ITALICS (MILLIMETERS OR AS NOTED)

Straight Duct with Rectangular Lateral Tap

NOTES:

- 1 **1** **OPTION:** CUSTOM LENGTH
- 2 **2** **OPTION:** RAW END
3. INTERIOR STIFFENERS (1" SCH40 PIPE) ARE WELDED BETWEEN THE OPPOSITE MIDPOINTS OF THE DUCT FLANGE FOR DUCT WIDTH OR DEPTH OF 50" (1270.0) WIDE OR GREATER.
4. DUCT WIDTH OR DEPTH OF 98" (2489.2) AND LARGER REQUIRES ENGINEERING REVIEW.
5. GREATER THAN STANDARD DUCT LENGTHS AND/OR HIGHER SYSTEM PRESSURES MAY REQUIRE ADDITIONAL STIFFENERS PER SMACNA, CONTACT FAB-TECH FOR SPECIFIC GUIDELINES.
6. ALL DUCT FITTINGS WITH STANDARD FAB-TECH CONNECTIONS INCLUDE GASKETS AND CLAMPS OR HARDWARE AS REQUIRED FOR INSTALLATION.

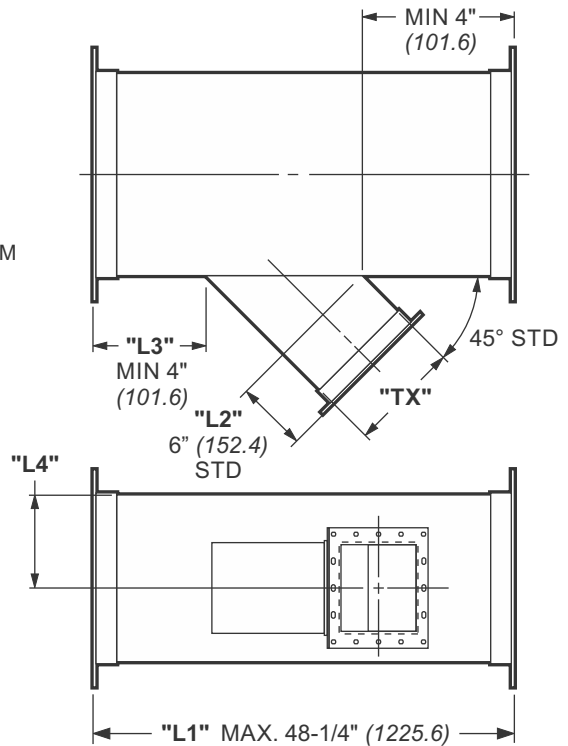
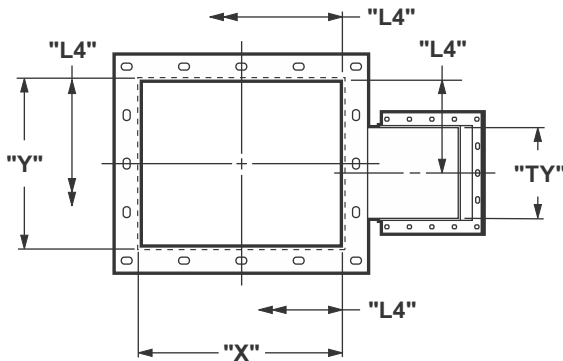

NOTES:

- 1 **1** **OPTION:** CUSTOM LENGTH
- 2 **2** **OPTION:** RAW END
3. INTERIOR STIFFENERS (1" SCH40 PIPE) ARE WELDED BETWEEN THE OPPOSITE MIDPOINTS OF THE DUCT FLANGE FOR DUCT WIDTH OR DEPTH OF 50" (1270.0) WIDE OR GREATER.
4. DUCT WIDTH OR DEPTH OF 98" (2489.2) AND LARGER REQUIRES ENGINEERING REVIEW.
5. GREATER THAN STANDARD DUCT LENGTHS AND/OR HIGHER SYSTEM PRESSURES MAY REQUIRE ADDITIONAL STIFFENERS PER SMACNA, CONTACT FAB-TECH FOR SPECIFIC GUIDELINES.
6. ALL DUCT FITTINGS WITH STANDARD FAB-TECH CONNECTIONS INCLUDE GASKETS AND CLAMPS OR HARDWARE AS REQUIRED FOR INSTALLATION.

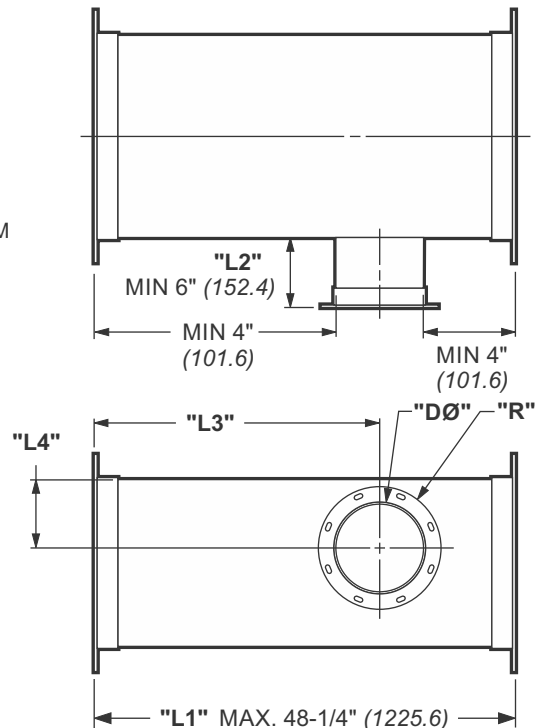
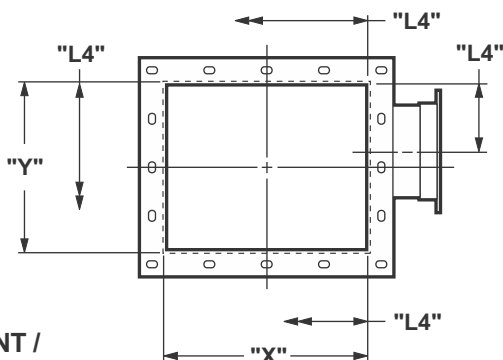

Straight Duct with Round Tap

DUCT JOINT / RING TYPE

- EZ** EZ CLAMP 4"Ø-14"Ø (101.6 - 355.6)
- SC** STAINLESS CAST RING 4"Ø-14"Ø (101.6 - 355.6)
- BI** BLACK IRON ANGLE RING 4"Ø-120"Ø (101.6 - 3048.0)
- SS** STAINLESS ANGLE RING 16"Ø-120"Ø (406.4 - 3048.0)

METRIC EQUIVALENTS ARE SHOWN IN PARENTHESIS & ITALICS (MILLIMETERS OR AS NOTED)

Straight Duct with Multiple Taps

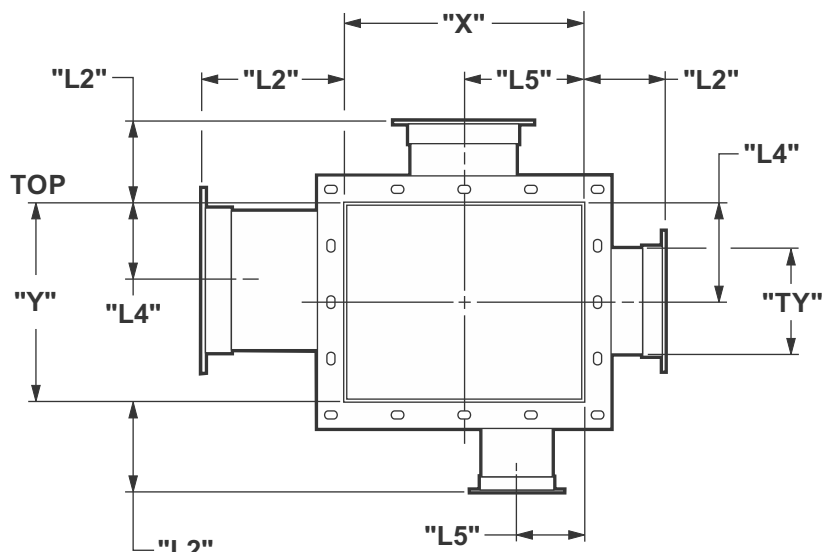
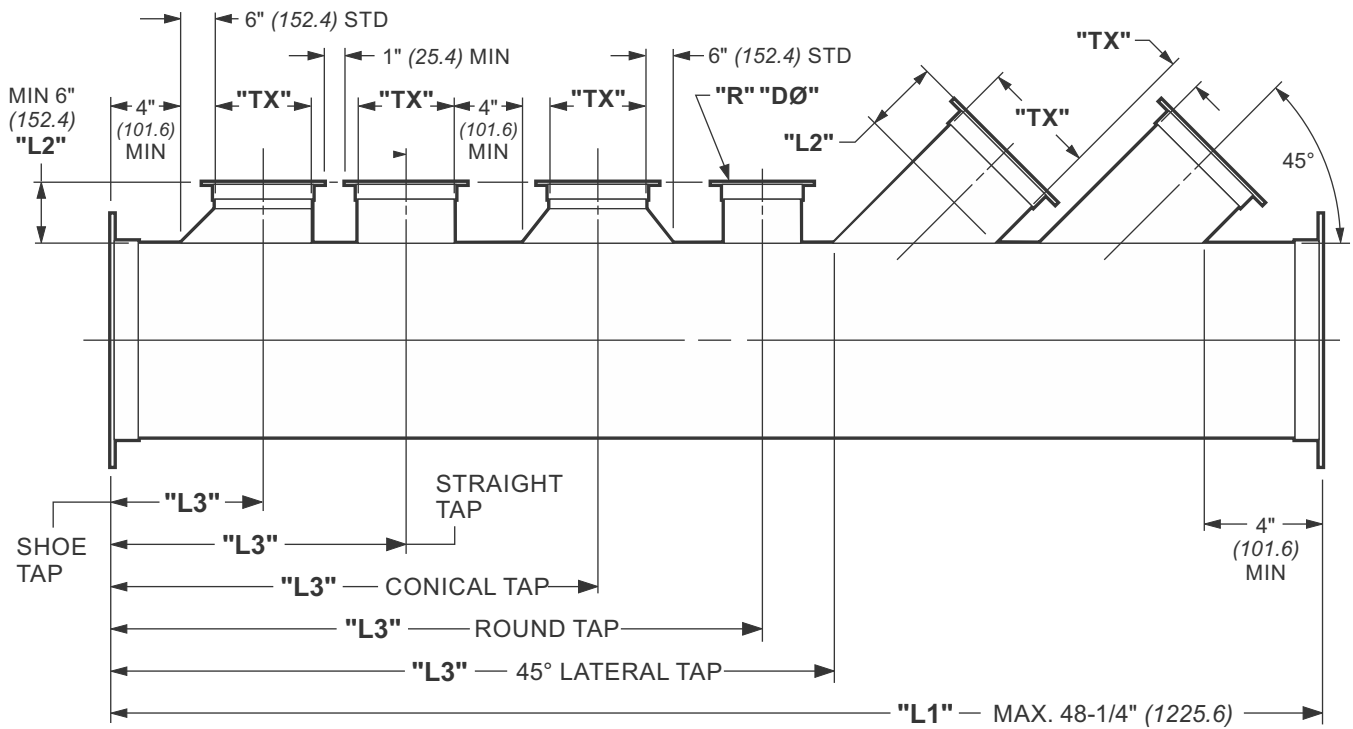

DUCT JOINT / RING TYPE

- EZ** EZ CLAMP
4"Ø-14"Ø (101.6 - 355.6)
- SC** STAINLESS CAST RING
4"Ø-14"Ø (101.6 - 355.6)
- BI** BLACK IRON ANGLE RING
4"Ø-120"Ø (101.6 - 3048.0)
- SS** STAINLESS ANGLE RING
16"Ø-120"Ø (406.4 - 3048.0)

NOTES:

1. **1** **OPTION:** CUSTOM LENGTH
2. **2** **OPTION:** RAW END
3. INTERIOR STIFFENERS (1" SCH40 PIPE) ARE WELDED BETWEEN THE OPPOSITE MIDPOINTS OF THE DUCT FLANGE FOR DUCT WIDTH OR DEPTH OF 50" (1270.0) WIDE OR GREATER.
4. DUCT WIDTH OR DEPTH OF 98" (2489.2) AND LARGER REQUIRES ENGINEERING REVIEW.
5. GREATER THAN STANDARD DUCT LENGTHS AND/OR HIGHER SYSTEM PRESSURES MAY REQUIRE ADDITIONAL STIFFENERS PER SMACNA, CONTACT FAB-TECH FOR SPECIFIC GUIDELINES.
6. ALL DUCT FITTINGS WITH STANDARD FAB-TECH CONNECTIONS INCLUDE GASKETS AND CLAMPS OR HARDWARE AS REQUIRED FOR INSTALLATION.

END VIEW

METRIC EQUIVALENTS ARE SHOWN IN PARENTHESIS & ITALICS (MILLIMETERS OR AS NOTED)

90°, 60°, 45°, 30° or Custom Elbow

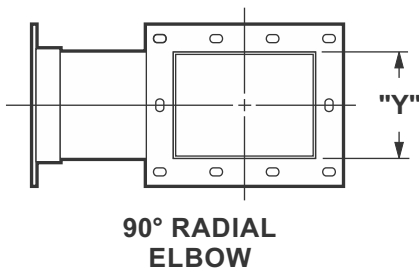
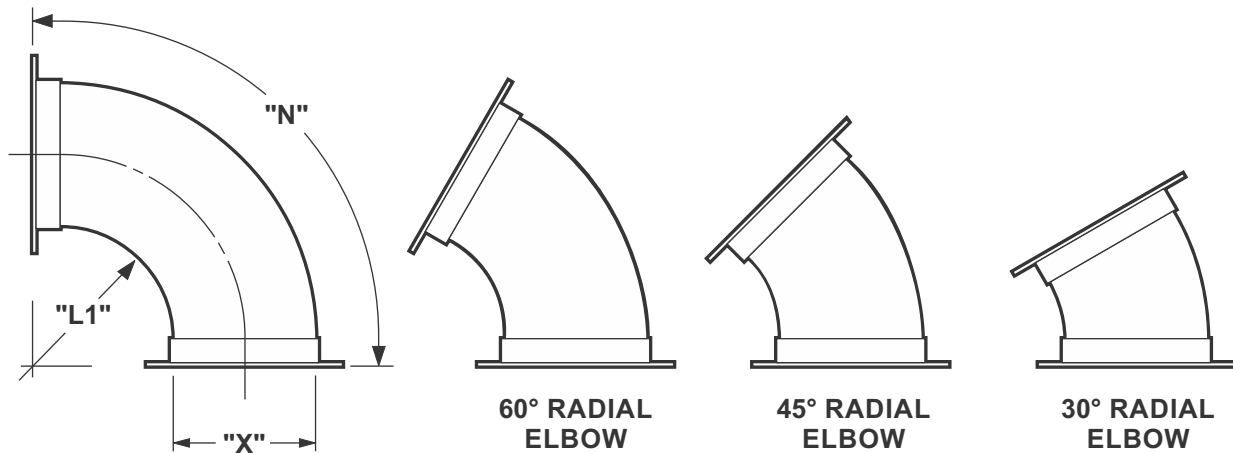

NOTES:

1. **2** *OPTION: RAW END*
2. INTERIOR STIFFENERS (1" SCH40 PIPE) ARE WELDED BETWEEN THE OPPOSITE MIDPOINTS OF THE DUCT FLANGE FOR DUCT WIDTH OR DEPTH OF 50" (1270.0) WIDE OR GREATER.
3. DUCT WIDTH OR DEPTH OF 98" (2489.2) AND LARGER REQUIRES ENGINEERING REVIEW.
4. GREATER THAN STANDARD DUCT LENGTHS AND/OR HIGHER SYSTEM PRESSURES MAY REQUIRE ADDITIONAL STIFFENERS PER SMACNA, CONTACT FAB-TECH FOR SPECIFIC GUIDELINES.
5. ALL DUCT FITTINGS WITH STANDARD FAB-TECH CONNECTIONS INCLUDE GASKETS AND CLAMPS OR HARDWARE AS REQUIRED FOR INSTALLATION.

90°, 60°, 45°, 30° or Custom Mitered Elbow

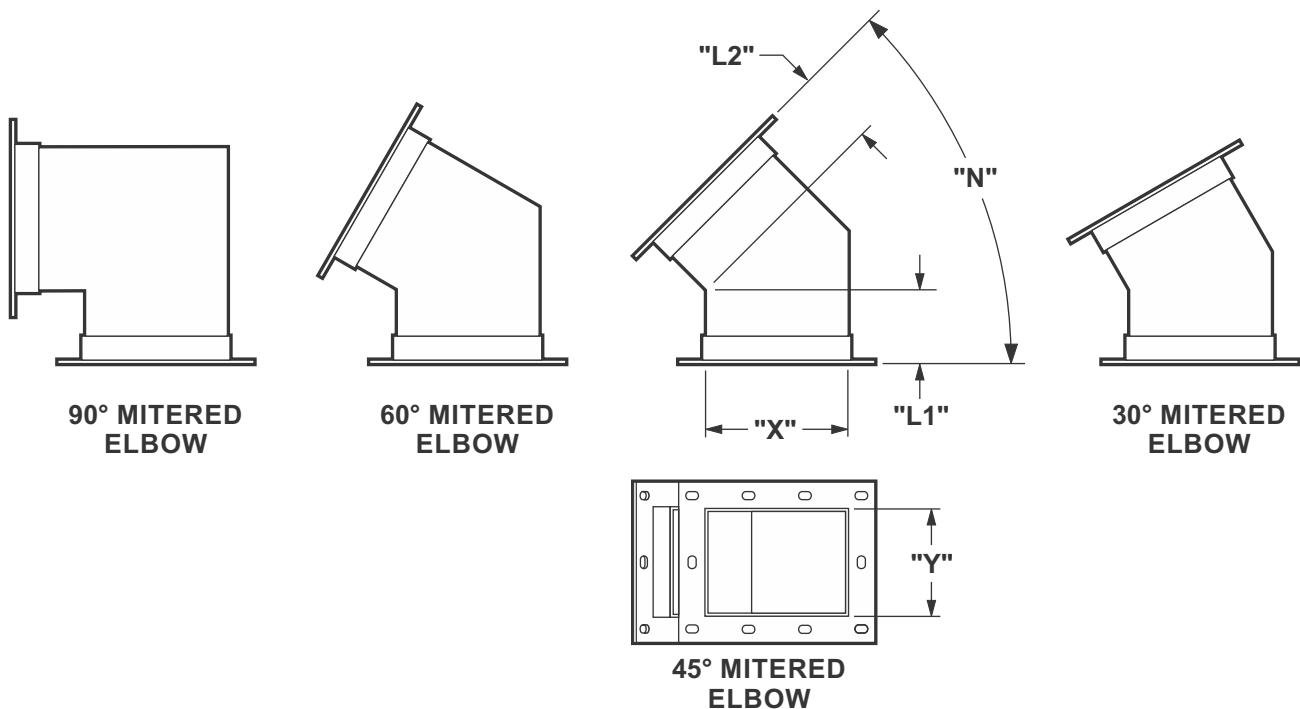

METRIC EQUIVALENTS ARE SHOWN IN PARENTHESIS & ITALICS (MILLIMETERS OR AS NOTED)

Concentric Transition

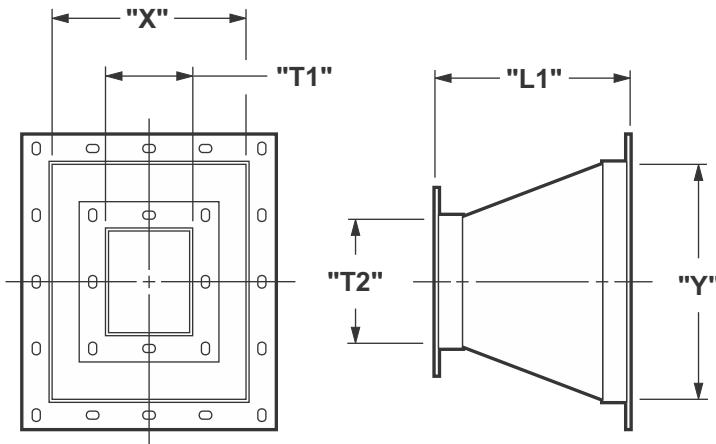

NOTES:

1. **2** **OPTION:** RAW END
2. INTERIOR STIFFENERS (1" SCH40 PIPE) ARE WELDED BETWEEN THE OPPOSITE MIDPOINTS OF THE DUCT FLANGE FOR DUCT WIDTH OR DEPTH OF 50" (1270.0) WIDE OR GREATER.
3. DUCT WIDTH OR DEPTH OF 98" (2489.2) AND LARGER REQUIRES ENGINEERING REVIEW.
4. GREATER THAN STANDARD DUCT LENGTHS AND/OR HIGHER SYSTEM PRESSURES MAY REQUIRE ADDITIONAL STIFFENERS PER SMACNA, CONTACT FAB-TECH FOR SPECIFIC GUIDELINES.
5. ALL DUCT FITTINGS WITH STANDARD FAB-TECH CONNECTIONS INCLUDE GASKETS AND CLAMPS OR HARDWARE AS REQUIRED FOR INSTALLATION.
6. FOR ECCENTRIC RECTANGULAR TO RECTANGULAR FITTING, USE THE CUSTOM FITTING ORDER SHEET.

Concentric Rectangular to Round Transition

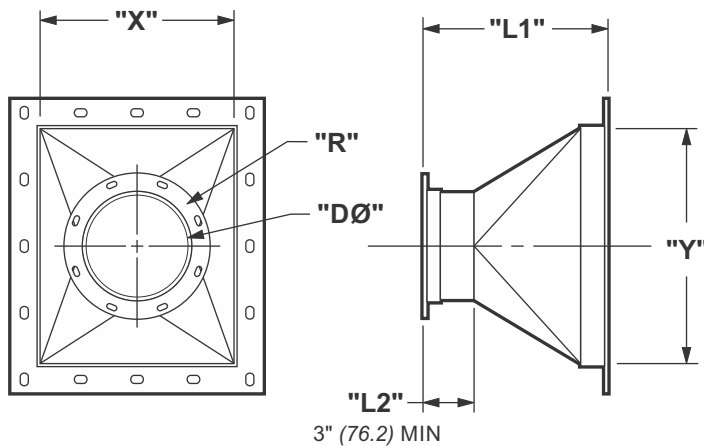

NOTES:

1. **2** **OPTION:** RAW END
2. INTERIOR STIFFENERS (1" SCH40 PIPE) ARE WELDED BETWEEN THE OPPOSITE MIDPOINTS OF THE DUCT FLANGE FOR DUCT WIDTH OR DEPTH OF 50" (1270.0) WIDE OR GREATER.
3. DUCT WIDTH OR DEPTH OF 98" (2489.2) AND LARGER REQUIRES ENGINEERING REVIEW.
4. GREATER THAN STANDARD DUCT LENGTHS AND/OR HIGHER SYSTEM PRESSURES MAY REQUIRE ADDITIONAL STIFFENERS PER SMACNA, CONTACT FAB-TECH FOR SPECIFIC GUIDELINES.
5. ALL DUCT FITTINGS WITH STANDARD FAB-TECH CONNECTIONS INCLUDE GASKETS AND CLAMPS OR HARDWARE AS REQUIRED FOR INSTALLATION.
6. FOR ECCENTRIC RECTANGULAR TO ROUND FITTING, USE THE CUSTOM FITTING ORDER SHEET.

DUCT JOINT / RING TYPE

- | | | | |
|--|---|---|---|
| EZ EZ CLAMP
4"Ø-14"Ø (101.6 - 355.6) | SC STAINLESS CAST RING
4"Ø-14"Ø (101.6 - 355.6) | BI BLACK IRON ANGLE RING
4"Ø-120"Ø (101.6 - 3048.0) | SS STAINLESS ANGLE RING
16"Ø-120"Ø (406.4 - 3048.0) |
|--|---|---|---|

METRIC EQUIVALENTS ARE SHOWN IN PARENTHESIS & ITALICS (MILLIMETERS OR AS NOTED)

Vertical Offset

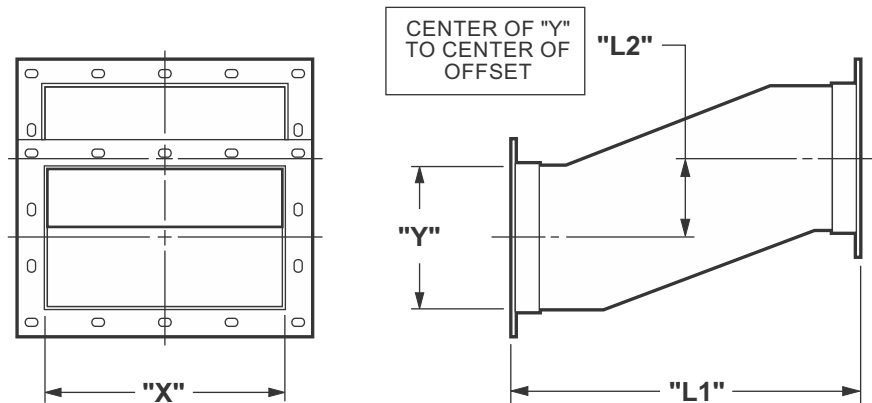

NOTES:

1. **2** *OPTION:* RAW END
2. INTERIOR STIFFENERS (1" SCH40 PIPE) ARE WELDED BETWEEN THE OPPOSITE MIDPOINTS OF THE DUCT FLANGE FOR DUCT WIDTH OR DEPTH OF 50" (1270.0) WIDE OR GREATER.
3. DUCT WIDTH OR DEPTH OF 98" (2489.2) AND LARGER REQUIRES ENGINEERING REVIEW.
4. GREATER THAN STANDARD DUCT LENGTHS AND/OR HIGHER SYSTEM PRESSURES MAY REQUIRE ADDITIONAL STIFFENERS PER SMACNA, CONTACT FAB-TECH FOR SPECIFIC GUIDELINES.
5. ALL DUCT FITTINGS WITH STANDARD FAB-TECH CONNECTIONS INCLUDE GASKETS AND CLAMPS OR HARDWARE AS REQUIRED FOR INSTALLATION.

Horizontal Offset

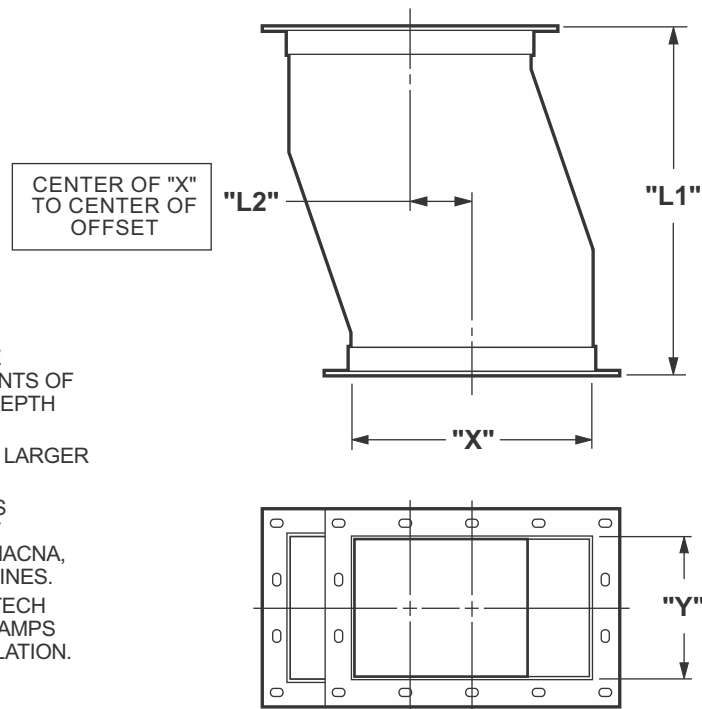

NOTES:

1. **2** *OPTION:* RAW END
2. INTERIOR STIFFENERS (1" SCH40 PIPE) ARE WELDED BETWEEN THE OPPOSITE MIDPOINTS OF THE DUCT FLANGE FOR DUCT WIDTH OR DEPTH OF 50" (1270.0) WIDE OR GREATER.
3. DUCT WIDTH OR DEPTH OF 98" (2489.2) AND LARGER REQUIRES ENGINEERING REVIEW.
4. GREATER THAN STANDARD DUCT LENGTHS AND/OR HIGHER SYSTEM PRESSURES MAY REQUIRE ADDITIONAL STIFFENERS PER SMACNA, CONTACT FAB-TECH FOR SPECIFIC GUIDELINES.
5. ALL DUCT FITTINGS WITH STANDARD FAB-TECH CONNECTIONS INCLUDE GASKETS AND CLAMPS OR HARDWARE AS REQUIRED FOR INSTALLATION.

METRIC EQUIVALENTS ARE SHOWN IN PARENTHESIS & ITALICS (MILLIMETERS OR AS NOTED)

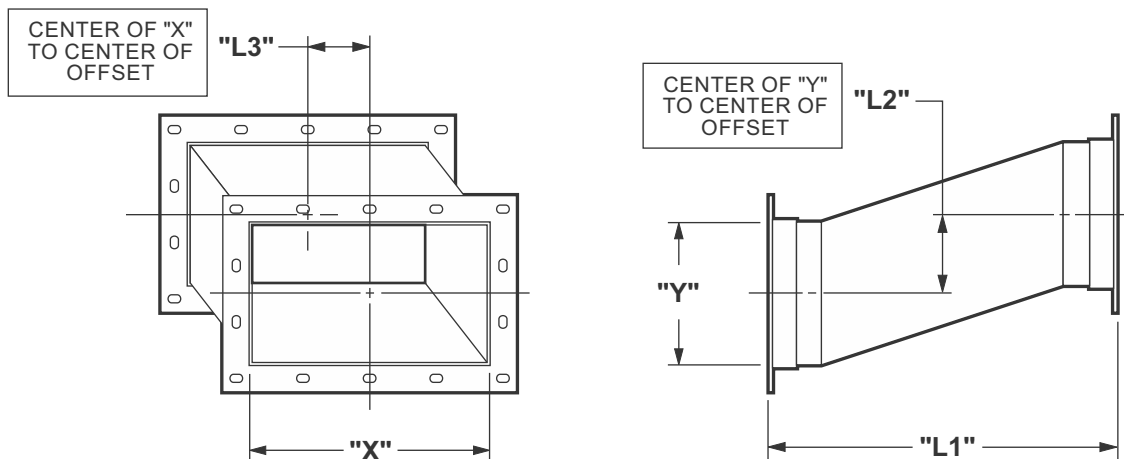

NOTES:

1. **2** *OPTION:* RAW END
2. INTERIOR STIFFENERS (1" SCH40 PIPE) ARE WELDED BETWEEN THE OPPOSITE MIDPOINTS OF THE DUCT FLANGE FOR DUCT WIDTH OR DEPTH OF 50" (1270.0) WIDE OR GREATER.
3. DUCT WIDTH OR DEPTH OF 98" (2489.2) AND LARGER REQUIRES ENGINEERING REVIEW.
4. GREATER THAN STANDARD DUCT LENGTHS AND/OR HIGHER SYSTEM PRESSURES MAY REQUIRE ADDITIONAL STIFFENERS PER SMACNA, CONTACT FAB-TECH FOR SPECIFIC GUIDELINES.
5. ALL DUCT FITTINGS WITH STANDARD FAB-TECH CONNECTIONS INCLUDE GASKETS AND CLAMPS OR HARDWARE AS REQUIRED FOR INSTALLATION.

End Cap

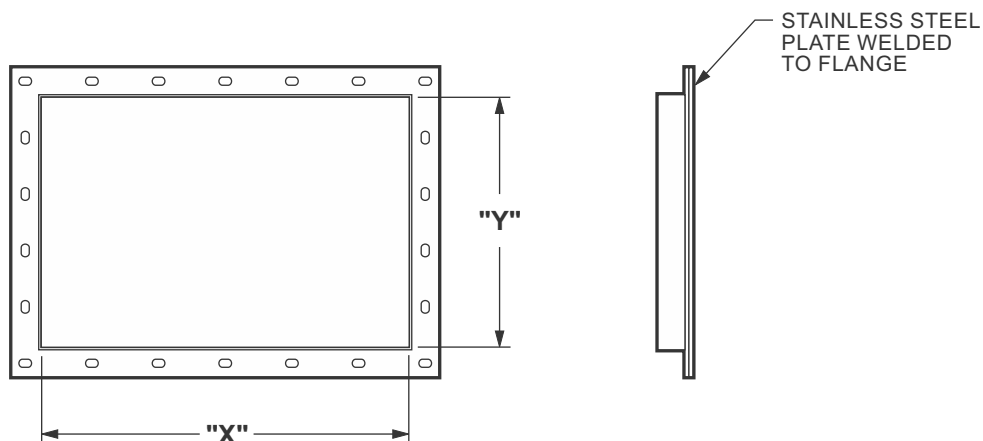

NOTES:

1. FLANGE MATERIAL WILL BE STAINLESS STEEL UNLESS OTHER MATERIAL IS SPECIFIED.
2. A STIFFENER (ANGLE MATERIAL MATCHING THE FRAME) IS ADDED AT THE FLANGE MIDPOINT OR WHERE AESTHETICALLY PLEASING FOR DUCT WIDTH OR DEPTH OF 50" (1270.0) AND GREATER (AS REQUIRED TO MEET MAXIMUM 4' (1219.2) SPACING).
3. DUCT WIDTH OR DEPTH OF 98" (2489.2) AND LARGER REQUIRES ENGINEERING REVIEW.
5. ALL DUCT FITTINGS WITH STANDARD FAB-TECH CONNECTIONS INCLUDE GASKETS AND CLAMPS OR HARDWARE AS REQUIRED FOR INSTALLATION.

METRIC EQUIVALENTS ARE SHOWN IN PARENTHESIS & ITALICS (MILLIMETERS OR AS NOTED)

**RECTANGULAR
CONTROL
DEVICES**

INDUSTRIAL
RECTANGULAR
PARALLEL BLADE
CONTROL DAMPER

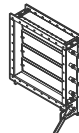

• PAGE: 93

INDUSTRIAL
RECTANGULAR
OPPOSED BLADE
CONTROL DAMPER



• PAGE: 93

INDUSTRIAL
RECTANGULAR
INDUSTRIAL
BACKDRAFT
DAMPER

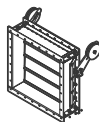

• PAGE: 94

HEAVY DUTY
RECTANGULAR
PARALLEL BLADE
CONTROL DAMPER

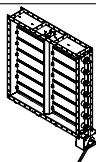

• PAGE: 95

HEAVY DUTY
RECTANGULAR
OPPOSED BLADE
CONTROL DAMPER

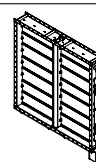

• PAGE: 95

HORIZONTAL
BLASTGATE

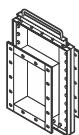

• PAGE: 96

VERTICAL
BLASTGATE

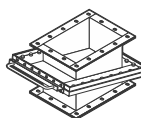

• PAGE: 96

METRIC EQUIVALENTS ARE SHOWN IN PARENTHESIS & ITALICS (MILLIMETERS OR AS NOTED)

Rectangular Damper Comparison Chart

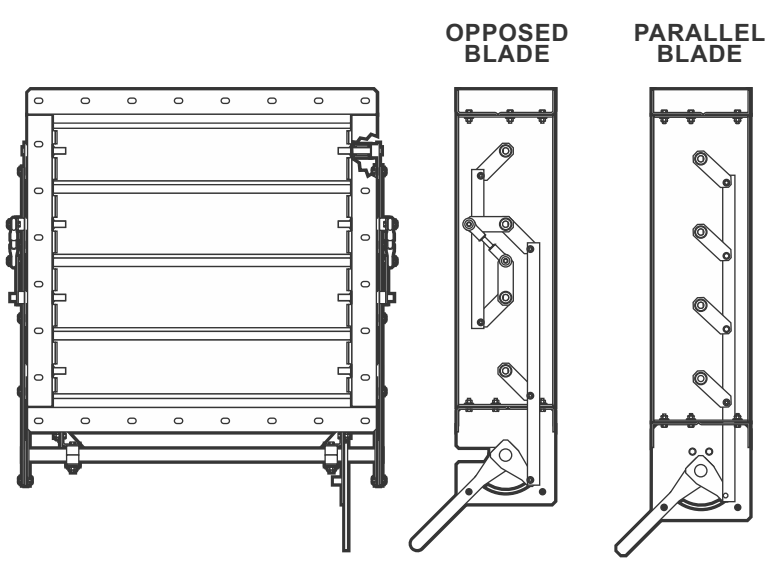

**8"x8" (203.2) to 36"x36" (914.4)
INDUSTRIAL CONTROL DAMPERS
PARALLEL OR OPPOSED BLADE CONFIG.**

FRAME: 10GA (3.57) STAINLESS STEEL:
CENTER SUPPORTS AS REQUIRED
FRAME LENGTH: 8" (203.2) STD
COATING: PERMASHIELD FLUOROPOLYMER BARRIER
JOINING SYSTEM: 2" (50.8) FLANGES
MOUNTING HOLES: .562" (14.27) X .75" (19.05) SLOTS:
≤ 4" (101.6) ON CENTER
BLADES: COATED 10GA (3.57) STAINLESS STEEL
AXLES: .50" (12.7) DIA. STAINLESS STEEL
SHAFT SEALS: LIQUID TIGHT
LINKAGE: LOCATED OUTSIDE THE AIRSTREAM:
TWIN DRIVE AS REQUIRED
QUADRANT PLATES: 10GA (3.57) STAINLESS STEEL
QUADRANT LEVER: .25" (6.35) STAINLESS STEEL
LOCKOUT: FULL OPEN / FULL CLOSE
FRAME SEALS: PTFE
ACTUATOR: MANUAL HANDLE
OPTION: CUSTOM ACTUATOR MOUNTING KIT
OPTION: BLANK ACTUATOR MOUNTING KIT
(PLATE & SHAFT ADAPTER) FOR
CUSTOMER SUPPLIED ACTUATOR
OPTION: PNEUMATIC ACTUATOR
OPTION: ELECTRIC ACTUATOR
OPTION: GEAR DRIVE WITH LOCKING DAMPER SHAFT

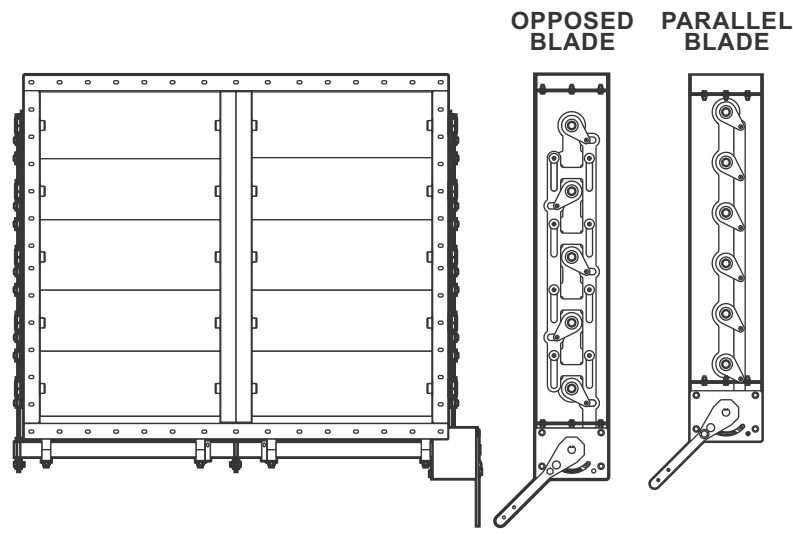

**36"x36" (914.4) to 120"x120" (3048.0)
HEAVY DUTY CONTROL DAMPERS
PARALLEL OR OPPOSED BLADE CONFIG.**

FRAME: 10GA (3.57) STAINLESS STEEL - CENTER SUPPORT
WITH LINKAGE REQUIRED FOR BLADES LONGER
THAN 36" (914.4)
FRAME LENGTH: 10" (254.0) STD
COATING: PERMASHIELD FLUOROPOLYMER BARRIER
JOINING SYSTEM: 2" (50.8) FLANGES
MOUNTING HOLES: .562" (14.27) X .750" (19.05) SLOTS:
3" (76.2) TO 4" (101.6) ON CENTER
BLADES: COATED 10GA (3.57) STAINLESS STEEL
AXLES: 1.38" DIA. (35.1) STAINLESS STEEL
SHAFT SEALS: LIQUID TIGHT
QUADRANT PLATES: 10GA (3.57) STAINLESS STEEL
QUADRANT LEVER: .25" (6.35) STAINLESS STEEL
LOCKOUT: FULL OPEN / FULL CLOSE
FRAME SEALS: PTFE
ACTUATOR: MANUAL HANDLE
OPTION: ACTUATOR MOUNTING KIT
OPTION: BLANK MOUNTING KIT - PLATE & SHAFT ADAPTER
FOR CUSTOMER SUPPLIED ACTUATOR
OPTION: PNEUMATIC ACTUATOR
OPTION: GEAR DRIVE WITH LOCKING DAMPER SHAFT
EXTERNAL LINKAGES: 10GA (3.57) STAINLESS STEEL
TWIN DRIVE AS REQUIRED

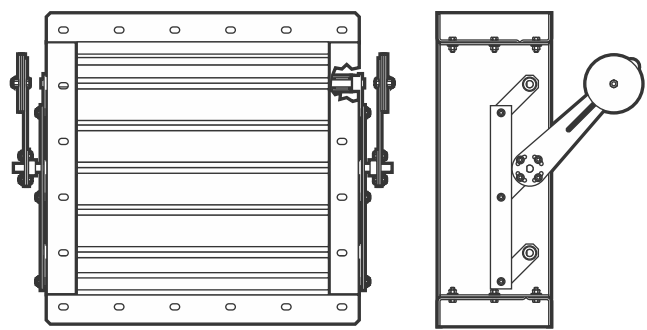

**8"x8" (914.4) to 120"x120" (3048.0)
INDUSTRIAL BACKDRAFT DAMPER**

FRAME: 10GA (3.57) STAINLESS STEEL:
CENTER SUPPORTS AS REQUIRED
FRAME LENGTH: 8" (203.2) STD
COATING: PERMASHIELD FLUOROPOLYMER BARRIER
JOINING SYSTEM: 2" (50.8) FLANGES
MOUNTING HOLES: .562" (14.27) X .75" (19.05) SLOTS:
≤ 4" (101.6) ON CENTER
BLADES: COATED 14GA (1.98) STAINLESS STEEL
AXLES: .50" (12.7) DIA. STAINLESS STEEL
SHAFT SEALS: LIQUID TIGHT
FRAME SEALS: PTFE
COUNTERWEIGHTS: MANUAL ADJUSTABLE
LINKAGES: 10GA (3.57) STAINLESS STEEL
LOCATED OUTSIDE AIRSTREAM:
TWIN DRIVE AS REQUIRED

METRIC EQUIVALENTS ARE SHOWN IN PARENTHESIS & ITALICS (MILLIMETERS OR AS NOTED)

Industrial Rectangular Parallel Blade Control Damper

SIZE: 8" X 8" (203.2) TO 36" X 36" (914.4)
FRAME: 10GA (3.57) STAINLESS STEEL:
 CENTER SUPPORTS AS REQUIRED
FRAME LENGTH: 8" (203.2) STD
COATING: PERMASHIELD FLUOROPOLYMER BARRIER
JOINING SYSTEM: 2" (50.8) FLANGES
MOUNTING HOLES: .562" (14.27) X .75" (19.05) SLOTS:
 ≤ 4" (101.6) ON CENTER
BLADES: COATED 10GA (3.57) STAINLESS STEEL
AXLES: .50" (12.7) DIA. STAINLESS STEEL
SHAFT SEALS: LIQUID TIGHT
LINKAGE: LOCATED OUTSIDE THE AIRSTREAM:
 TWIN DRIVE AS REQUIRED
QUADRANT PLATES: 10GA (3.57) STAINLESS STEEL
QUADRANT LEVER: .25" (6.35) STAINLESS STEEL
LOCKOUT: FULL OPEN / FULL CLOSE
FRAME SEALS: PTFE
ACTUATOR: MANUAL HANDLE
OPTION: CUSTOM ACTUATOR MOUNTING KIT
OPTION: BLANK ACTUATOR MOUNTING KIT
 (PLATE & SHAFT ADAPTER) FOR
 CUSTOMER SUPPLIED ACTUATOR
OPTION: PNEUMATIC ACTUATOR
OPTION: ELECTRIC ACTUATOR
OPTION: GEAR DRIVE WITH LOCKING DAMPER SHAFT

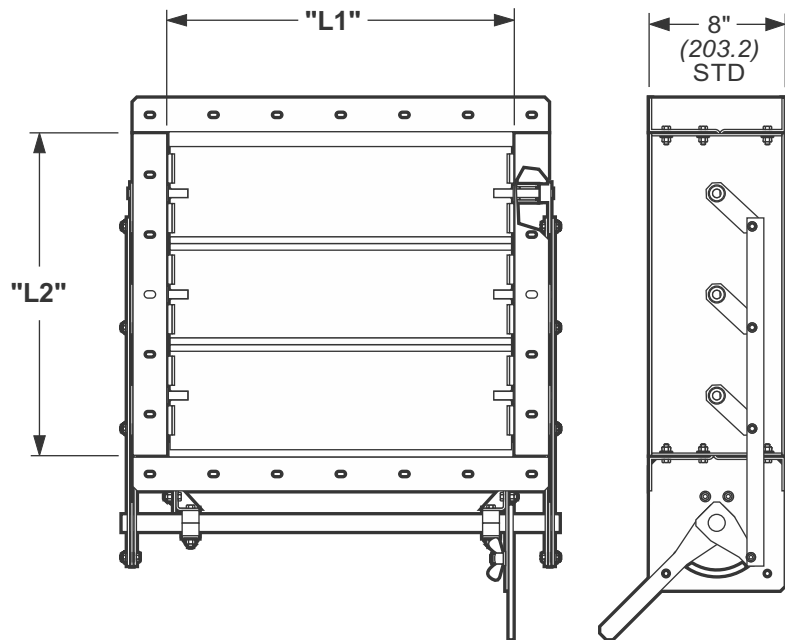

NOTES:

1. FOR "L1" OR "L2" LONGER THAN 36" (914.4) - **HEAVY DUTY DAMPER IS REQUIRED.**
2. ALL DUCT FITTINGS WITH STANDARD FAB-TECH CONNECTIONS INCLUDE GASKETS AND CLAMPS OR HARDWARE AS REQUIRED FOR INSTALLATION.

Industrial Rectangular Opposed Blade Control Damper

SIZE: 8" X 8" (203.2) TO 36" X 36" (914.4)
FRAME: 10GA (3.57) STAINLESS STEEL:
 CENTER SUPPORTS AS REQUIRED
FRAME LENGTH: 8" (203.2) STD
COATING: PERMASHIELD FLUOROPOLYMER BARRIER
JOINING SYSTEM: 2" (50.8) FLANGES
MOUNTING HOLES: .562" (14.27) X .75" (19.05) SLOTS:
 ≤ 4" (101.6) ON CENTER
BLADES: COATED 10GA (3.57) STAINLESS STEEL
AXLES: .50" (12.7) DIA. STAINLESS STEEL
SHAFT SEALS: LIQUID TIGHT
LINKAGE: LOCATED OUTSIDE THE AIRSTREAM:
 TWIN DRIVE AS REQUIRED
QUADRANT PLATES: 10GA (3.57) STAINLESS STEEL
QUADRANT LEVER: .25" (6.35) STAINLESS STEEL
LOCKOUT: FULL OPEN / FULL CLOSE
FRAME SEALS: PTFE
ACTUATOR: MANUAL HANDLE
OPTION: CUSTOM ACTUATOR MOUNTING KIT
OPTION: BLANK ACTUATOR MOUNTING KIT
 (PLATE & SHAFT ADAPTER) FOR
 CUSTOMER SUPPLIED ACTUATOR
OPTION: PNEUMATIC ACTUATOR
OPTION: ELECTRIC ACTUATOR
OPTION: GEAR DRIVE WITH LOCKING DAMPER SHAFT

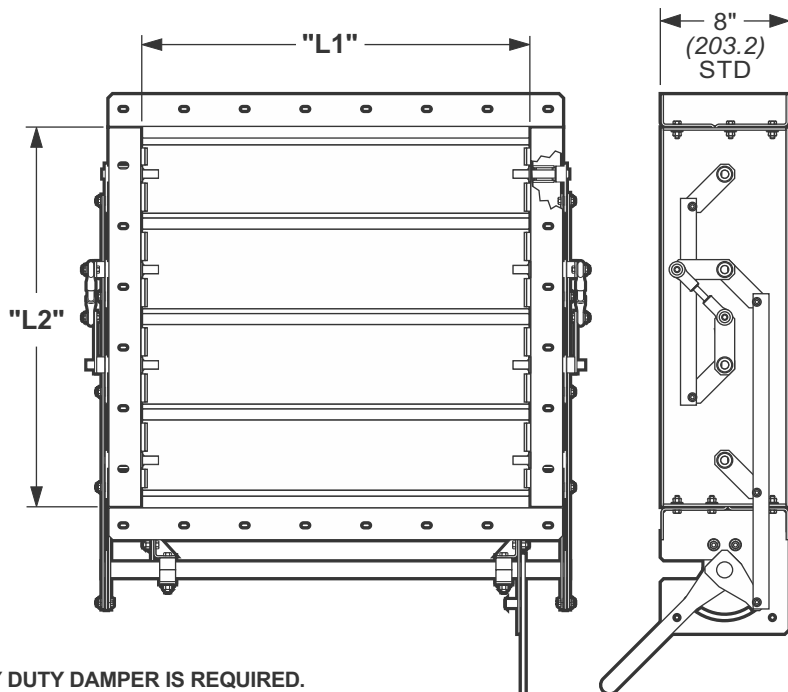

NOTES:

1. FOR "L1" OR "L2" LONGER THAN 36" (914.4) - **HEAVY DUTY DAMPER IS REQUIRED.**
2. ALL DUCT FITTINGS WITH STANDARD FAB-TECH CONNECTIONS INCLUDE GASKETS AND CLAMPS OR HARDWARE AS REQUIRED FOR INSTALLATION.

METRIC EQUIVALENTS ARE SHOWN IN PARENTHESIS & ITALICS (MILLIMETERS OR AS NOTED)

Industrial Rectangular Backdraft Damper

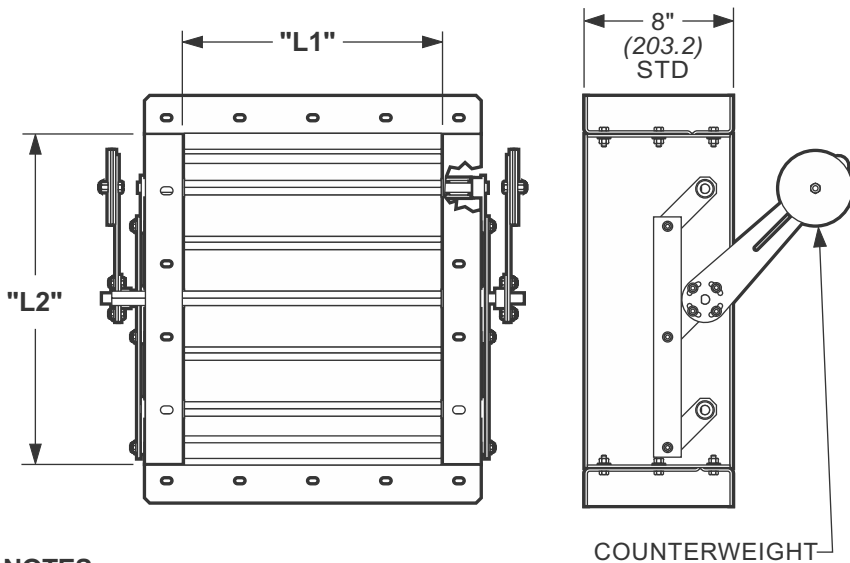

- SIZE:** 8" X 8" (914.4) TO 120" X 120" (3048.0)
- FRAME:** 10GA (3.57) STAINLESS STEEL:
CENTER SUPPORTS AS REQUIRED
- FRAME LENGTH:** 8" (203.2) STD
- COATING:** PERMASHIELD FLUOROPOLYMER
BARRIER COATING
- JOINING SYSTEM:** 2" (50.8) FLANGES
- MOUNTING HOLES:** .562" (14.27) X .75" (19.05) SLOTS:
≤ 4" (101.6) ON CENTER
- BLADES:** COATED 14GA (1.98) STAINLESS STEEL
- AXLES:** .50" (12.7) DIA. STAINLESS STEEL
- SHAFT SEALS:** LIQUID TIGHT
- FRAME SEALS:** PTFE
- COUNTERWEIGHTS:** MANUAL ADJUSTABLE
- LINKAGES:** 10GA (3.57) STAINLESS STEEL
LOCATED OUTSIDE AIRSTREAM:
TWIN DRIVE AS REQUIRED

NOTES:

1. CENTER SUPPORT REQUIRED FOR BLADES LONGER THAN 36" (914.4) ("L1")
2. ALL DUCT FITTINGS WITH STANDARD FAB-TECH CONNECTIONS INCLUDE GASKETS AND CLAMPS OR HARDWARE AS REQUIRED FOR INSTALLATION.

METRIC EQUIVALENTS ARE SHOWN IN PARENTHESIS & ITALICS (MILLIMETERS OR AS NOTED)

Heavy Duty Rectangular Parallel Blade Control Damper

- SIZE:** 36" X 36" (914.4) X 120" X 120" (3048.0)
FRAME: 10GA (3.57) STAINLESS STEEL:
 CENTER SUPPORTS WITH LINKAGE AS REQUIRED
 FOR BLADES LONGER THAN 36" (914.4)
FRAME LENGTH: 10" (254.0) STD
COATING: PERMASHIELD FLUOROPOLYMER BARRIER
JOINING SYSTEM: 2" (50.8) FLANGES
MOUNTING HOLES: .562" (14.27) X .75" (19.05) SLOTS:
 3" (76.2) TO 4" (101.6) ON CENTER
BLADES: COATED 10GA (3.57) STAINLESS STEEL
AXLES: 1.38" (35.05) DIA. STAINLESS STEEL
SHAFT SEALS: LIQUID TIGHT
LINKAGE: 10GA (3.57) STAINLESS STEEL
 LOCATED OUTSIDE THE AIRSTREAM:
 TWIN DRIVE AS REQUIRED
QUADRANT PLATES: 10GA (3.57) STAINLESS STEEL
QUADRANT LEVER: .25" (6.35) STAINLESS STEEL
LOCKOUT: FULL OPEN / FULL CLOSE
FRAME SEALS: PTFE
ACTUATOR: MANUAL HANDLE
OPTION: CUSTOM ACTUATOR MOUNTING KIT
OPTION: BLANK ACTUATOR MOUNTING KIT
 (PLATE & SHAFT ADAPTER) FOR
 CUSTOMER SUPPLIED ACTUATOR
OPTION: PNEUMATIC ACTUATOR
OPTION: ELECTRIC ACTUATOR
OPTION: GEAR DRIVE WITH LOCKING DAMPER SHAFT

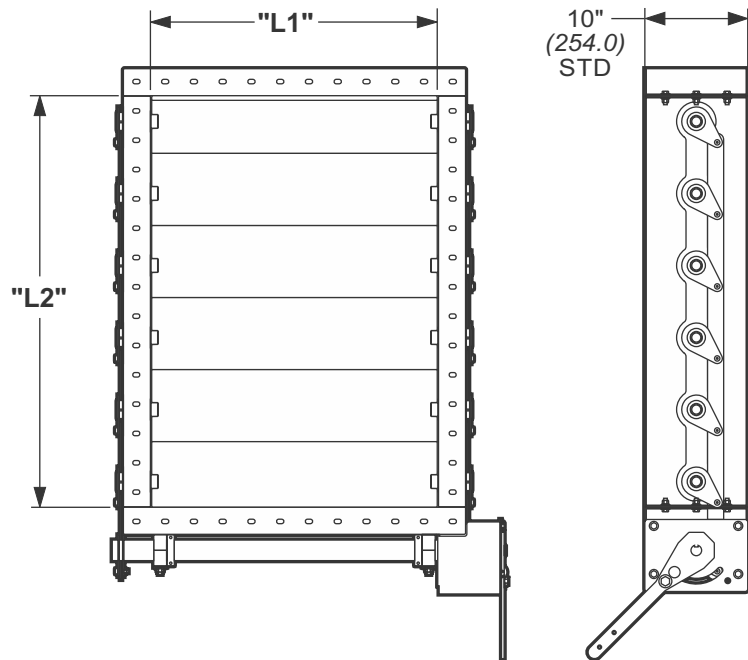

NOTES:

1. CENTER SUPPORT W/ CENTER LINKAGE REQUIRED FOR BLADES LONGER THAN 36" (914.4) ("L1").
2. ALL DUCT FITTINGS WITH STANDARD FAB-TECH CONNECTIONS INCLUDE GASKETS AND CLAMPS OR HARDWARE AS REQUIRED FOR INSTALLATION.

Heavy Duty Rectangular Opposed Blade Control Damper

- SIZE:** 36" X 36" (914.4) X 120" X 120" (3048.0)
FRAME: 10GA (3.57) STAINLESS STEEL:
 CENTER SUPPORTS WITH LINKAGE AS REQUIRED
 FOR BLADES LONGER THAN 36" (914.4)
FRAME LENGTH: 10" (254.0) STD
COATING: PERMASHIELD FLUOROPOLYMER BARRIER
JOINING SYSTEM: 2" (50.8) FLANGES
MOUNTING HOLES: .562" (14.27) X .75" (19.05) SLOTS:
 3" (76.2) TO 4" (101.6) ON CENTER
BLADES: COATED 10GA (3.57) STAINLESS STEEL
AXLES: 1.38" (35.05) DIA. STAINLESS STEEL
SHAFT SEALS: LIQUID TIGHT
LINKAGE: 10GA (3.57) STAINLESS STEEL
 LOCATED OUTSIDE THE AIRSTREAM:
 TWIN DRIVE AS REQUIRED
QUADRANT PLATES: 10GA (3.57) STAINLESS STEEL
QUADRANT LEVER: .25" (6.35) STAINLESS STEEL
LOCKOUT: FULL OPEN / FULL CLOSE
FRAME SEALS: PTFE
ACTUATOR: MANUAL HANDLE
OPTION: CUSTOM ACTUATOR MOUNTING KIT
OPTION: BLANK ACTUATOR MOUNTING KIT
 (PLATE & SHAFT ADAPTER) FOR
 CUSTOMER SUPPLIED ACTUATOR
OPTION: PNEUMATIC ACTUATOR
OPTION: ELECTRIC ACTUATOR
OPTION: GEAR DRIVE WITH LOCKING DAMPER SHAFT

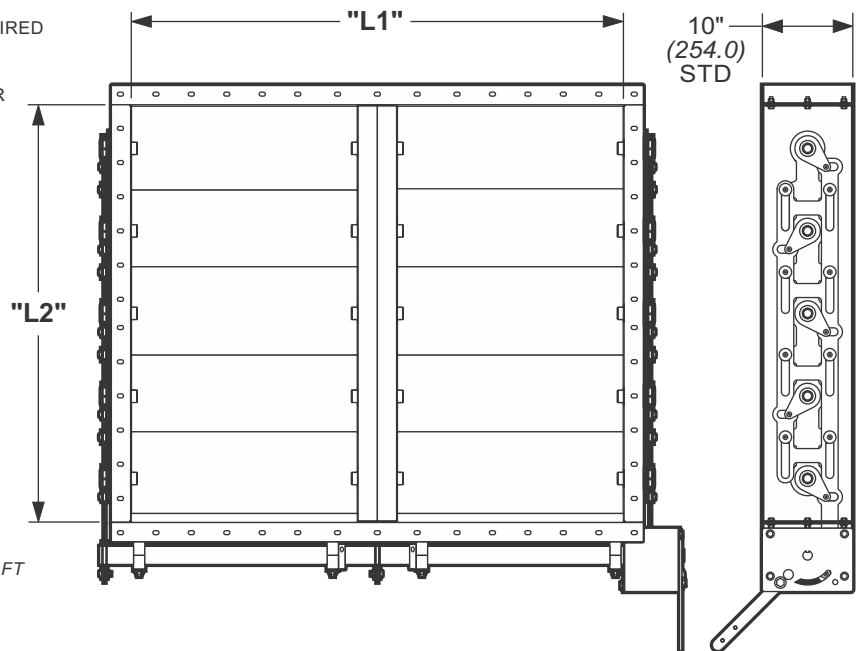

NOTES:

1. CENTER SUPPORT W/ CENTER LINKAGE REQUIRED FOR BLADES LONGER THAN 36" (914.4) ("L1").
2. ALL DUCT FITTINGS WITH STANDARD FAB-TECH CONNECTIONS INCLUDE GASKETS AND CLAMPS OR HARDWARE AS REQUIRED FOR INSTALLATION.

METRIC EQUIVALENTS ARE SHOWN IN PARENTHESIS & ITALICS (MILLIMETERS OR AS NOTED)

Horizontal Blastgate

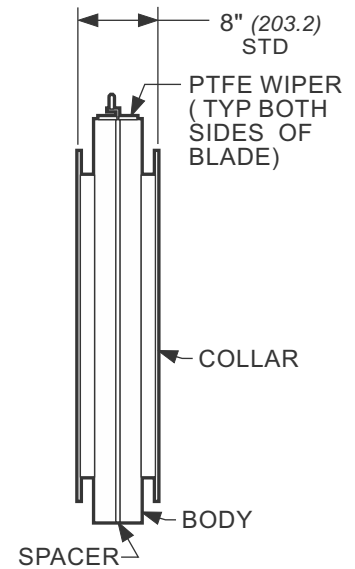
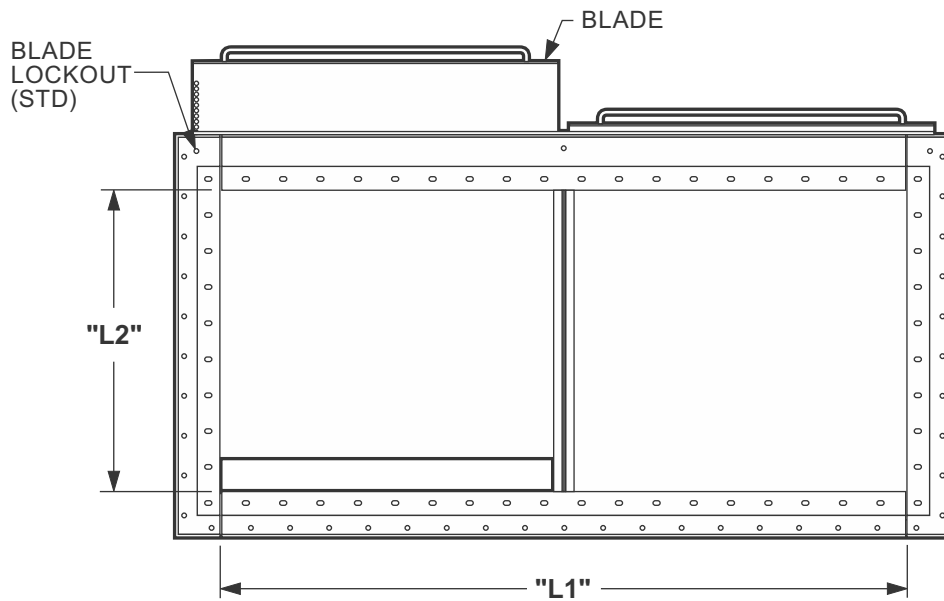

NOTES:

1. STAINLESS STEEL BODY, RINGS AND BLADES - BLADE LOCKOUT SYSTEM.
2. CENTER SUPPORT REQUIRED FOR BLADES LONGER THAN 36" (914.4) ("L1").
3. DUCT WIDTH OR DEPTH OF 98" (2489.2) AND LARGER REQUIRES ENGINEERING REVIEW.
4. ALL DUCT FITTINGS WITH STANDARD FAB-TECH CONNECTIONS INCLUDE GASKETS AND CLAMPS OR HARDWARE AS REQUIRED FOR INSTALLATION.

Vertical Blastgate

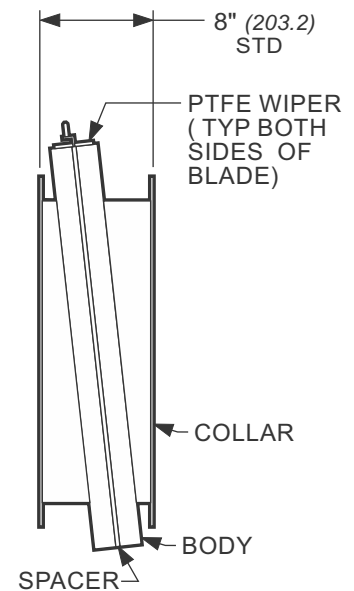
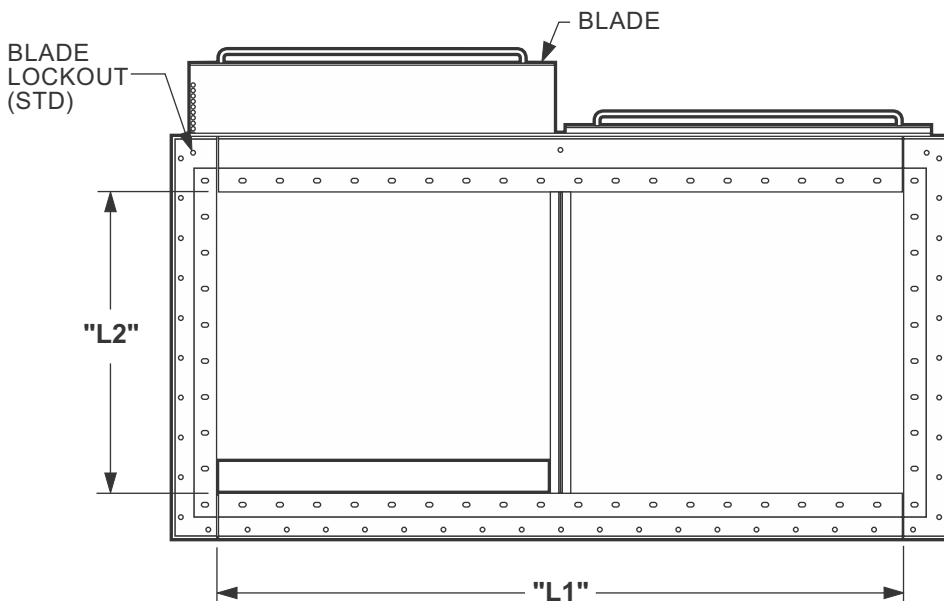

NOTES:

1. STAINLESS STEEL BODY, RINGS AND BLADES - BLADE LOCKOUT SYSTEM.
2. CENTER SUPPORT REQUIRED FOR BLADES LONGER THAN 36" (914.4) ("L1").
3. DUCT WIDTH OR DEPTH OF 98" (2489.2) AND LARGER REQUIRES ENGINEERING REVIEW.
4. ALL DUCT FITTINGS WITH STANDARD FAB-TECH CONNECTIONS INCLUDE GASKETS AND CLAMPS OR HARDWARE AS REQUIRED FOR INSTALLATION.

METRIC EQUIVALENTS ARE SHOWN IN PARENTHESIS & ITALICS (MILLIMETERS OR AS NOTED)